

SAMSUNG

VRF Technical Data Book

Wind-Free 1Way Cassette for Global
(R410A, 50Hz)



Model : AM***NN1*EH/**

History

Version	Modification	Date	Remark
Ver. 1.0	Release VRF Wind-Free 1Way Cassette for Global TDB (50Hz)	'17.11.22	
Ver. 1.1	Revised some errors of panel Weight/Shipping Dimensions.	'18.04.19	
Ver. 1.2	Added Wind-Free Performance Characteristics in Summary Table	'18.05.16	
Ver. 1.2.1	Modified Accessory table error (P.48)	'18.09.18	

Nomenclature

Indoor Units

Model Names

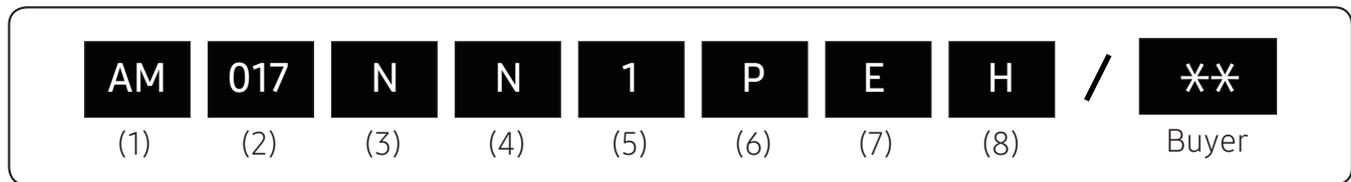

(1) Classification

AM	DVM
-----------	-----

(2) Capacity

X 100 Watt (3 digits)

(3) Version

K	2016
M	2017
N	2018

(4) Product Type

N	Indoor Unit
X	Outdoor Unit

(5) Product Notation

1	1Way Cassette
----------	---------------

(6) Feature

P	Premium
D	Deluxe

(7) Rating Voltage

E	1Ø, 220~240V, 50Hz
----------	--------------------

(8) Mode

H	Heat Pump (R410A)
----------	-------------------

Features & Benefits

1. Wind-Free cooling

Comfort wind implementation by Wind-Free cooling

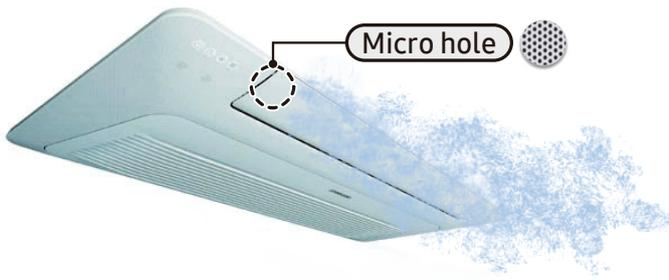

※ Wind-Free implementation : Still air by the velocity of flow below 0.15m/s.

2. Big blade

Max. 8m Horizontal reach

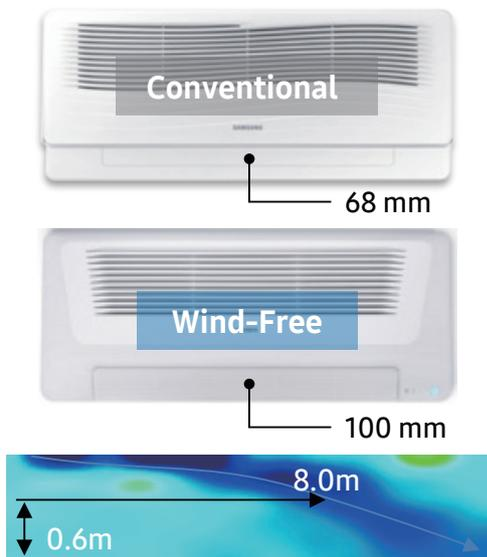

- ※ Blade enlargement about 47% compare to conventional product
- ※ Reach : 8m (Height 0.6m, Wind speed 0.3m/s)
Conventional product (Samsung) : 5m
- ※ Based on Wind-Free 1Way 7.1kW

3. Even cooling

Even cooling For spacious space

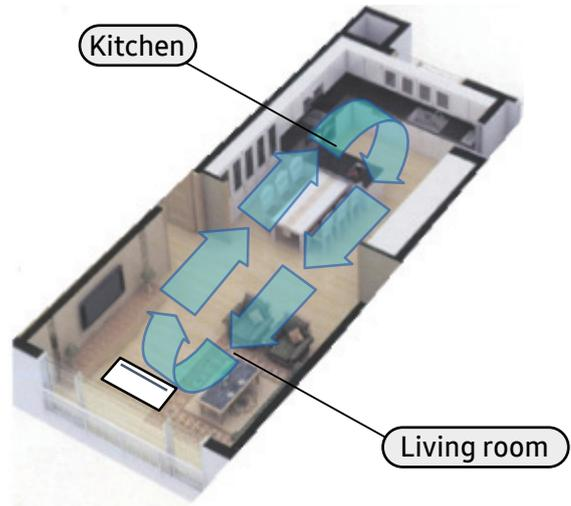

※ Expand the blade angle from 30° to 80°
Conventional product (Samsung) : 40~80 °

Contents

1. Line up	6
2. Specification	7
3. Summary Table	13
4. Capacity Table	14
5. Dimensional Drawing	18
6. Center of Gravity	21
7. Electrical Wiring Diagram	22
8. Sound data	24
9. Temperature and Air Flow Distribution	28
10. Piping Diagram	35
11. Installation	36
12. Accessory	44

1. Line up

Wind free 1 Way Cassette

Capacity (kW)	1.7	2.2	2.2	2.8	3.6	5.6	7.1
Wind free 1 Way Cassette							
Type	Small		Middle			Large	
Model Name	AM017NN1PEH/**	AM022NN1PEH/**	AM022NN1DEH/**	AM028NN1DEH/**	AM036NN1DEH/**	AM056NN1DEH/**	AM071NN1DEH/**

2. Specification

Wind free 1 Way Cassette

Type				1Way CASSETTE	1Way CASSETTE
Model Name				AM017NN1PEH/XX	AM022NN1PEH/XX
Power Supply			Φ, #, V, Hz	1,2,220-240,50	1,2,220-240,50
Mode			-	HP/HR	HP/HR
Performance	Capacity	Cooling	kW	1.70	2.20
			Btu/h	5,800	7,500
		Heating	kW	1.90	2.50
			Btu/h	6,500	8,500
Power	Power Input	Cooling	W	24.00	25.00
		Heating		24.00	25.00
	Current Input	Cooling	A	0.14	0.15
		Heating		0.14	0.15
	Current	MCA	A	0.18	0.19
		MFA		15	15
Heat exchanger	Type		-	Fin & Tube	Fin & Tube
	Material	Fin	-	Al	Al
		Tube	-	Cu	Cu
	Fin Treatment		-	Green Hydrophile	Green Hydrophile
Fan	Type		-	Crossflow Fan	Crossflow Fan
	Quantity		ea	1	1
	Air Flow Rate	H/M/L	m ³ /min	4.80/4.30/4.10	5.10/4.60/4.30
			l/s	80.00/71.67/68.33	85.00/76.67/71.67
Fan Motor	Model		-	BLDC Motor	BLDC Motor
	Output x n		W	27 x 1	27 x 1
Piping Connections	Liquid Pipe		Type	Flare Connection	Flare Connection
			Φ, mm	6.35	6.35
			Φ, inch	1/4"	1/4"
	Gas Pipe		Type	Flare Connection	Flare Connection
			Φ, mm	12.70	12.70
			Φ, inch	1/2"	1/2"
Drain Pipe		Φ, mm	VP20 (OD 25,ID 20)	VP20 (OD 25,ID 20)	
Wiring connections	Communication	Minimum	mm ²	0.75	0.75
		Remark	-	F1, F2	F1, F2
Refrigerant	Type		-	R410A	R410A
	Electronic Expansion Valve		-	EEV INCLUDED	EEV INCLUDED
Sound	Sound Pressure	High / Mid / Low	dB(A)	28 / 26 / 24	29 / 26 / 24
	Sound Power	Cooling		46	47
Dimension	Net Weight		kg	8.0	8.0
	Shipping Weight		kg	10.5	10.5
	Net Dimensions (WxHxD)		mm	740 x 135 x 360	740 x 135 x 360
	Shipping Dimensions (WxHxD)		mm	895 x 223 x 435	895 x 223 x 435

2. Specification

Wind free 1 Way Cassette

Type			1Way CASSETTE	1Way CASSETTE
Model Name			AM017NN1PEH/XX	AM022NN1PEH/XX
Casing	Material	-	ABS	ABS
Panel	Model Name	-	PC1MWFMAN	PC1MWFMAN
	Type	-	Wind Free	Wind Free
	Material	-	HIPS	HIPS
	Color	-	White	White
	Net Weight	kg	2.6	2.6
	Shipping Weight	kg	3.8	3.8
	Net Dimensions (W×H×D)	mm	960 x 35 x 420	960 x 35 x 420
	Shipping Dimensions (W×H×D)	mm	1003 x 112 x 482	1003 x 112 x 482
Drain pump		-	INCLUDED	INCLUDED
	Max. lifting Height / Displacement	mm / Liter/h	750 / 24	750 / 24

NOTE

- Mode : HP(Heat Pump), HR(Heat Recovery)
- Cooling : Indoor temperature 27°C DB / 19°C WB, Outdoor temperature 35°C DB/24°C WB, Refrigerant pipe length 7.5m, Level difference 0m.
- Heating : Indoor temperature 20°C DB / 15°C WB, Outdoor temperature 7°C DB / 6°C WB, Refrigerant pipe length 7.5m, Level difference 0m.
- Sound level was acquired in an anechoic room. Thus actual noise level may be different depending on the installation conditions.
- These products contain R410A (GWP=2,088) which is fluorinated greenhouse gas.
- Specifications may be subject to change without prior notice.
- Select wire size based on the value of MCA
- Drain pump included (check valve included)

2. Specification

Wind free 1 Way Cassette

Type				1Way CASSETTE	1Way CASSETTE	1Way CASSETTE
Model Name				AM022NN1DEH/XX	AM028NN1DEH/XX	AM036NN1DEH/XX
Power Supply		Φ, #, V, Hz		1,2,220-240,50	1,2,220-240,50	1,2,220-240,50
Mode			-	HP/HR	HP/HR	HP/HR
Performance	Capacity	Cooling	kW	2.20	2.80	3.60
			Btu/h	7,500	9,600	12,300
		Heating	kW	2.50	3.20	4.00
			Btu/h	8,500	10,900	13,600
Power	Power Input	Cooling	W	40.00	45.00	50.00
		Heating		40.00	45.00	50.00
	Current Input	Cooling	A	0.20	0.23	0.25
		Heating		0.20	0.23	0.25
	Current	MCA	A	0.25	0.29	0.31
		MFA		15	15	15
Heat exchanger	Type		-	Fin & Tube	Fin & Tube	Fin & Tube
	Material	Fin	-	Al	Al	Al
		Tube	-	Cu	Cu	Cu
	Fin Treatment		-	Green Hydrophile	Green Hydrophile	Green Hydrophile
Fan	Type		-	Crossflow Fan	Crossflow Fan	Crossflow Fan
	Quantity		ea	1	1	1
	Air Flow Rate	H/M/L	m ³ /min	6.00/5.00/4.00	7.00/6.00/5.00	8.00/7.00/6.00
			l/s	100.00/83.33/66.67	116.67/100.00/83.33	133.33/116.67/100.00
Fan Motor	Model		-	AC Motor	AC Motor	AC Motor
	Output x n		W	17 x 1	17 x 1	17 x 1
Piping Connections	Liquid Pipe		Type	Flare Connection	Flare Connection	Flare Connection
			Φ, mm	6.35	6.35	6.35
			Φ, inch	1/4"	1/4"	1/4"
	Gas Pipe		Type	Flare Connection	Flare Connection	Flare Connection
			Φ, mm	12.70	12.70	12.70
			Φ, inch	1/2"	1/2"	1/2"
Drain Pipe		Φ, mm	VP20 (OD 25,ID 20)	VP20 (OD 25,ID 20)	VP20 (OD 25,ID 20)	
Wiring connections	Communication	Minimum	mm ²	0.75	0.75	0.75
		Remark	-	F1, F2	F1, F2	F1, F2
Refrigerant	Type		-	R410A	R410A	R410A
	Electronic Expansion Valve		-	EEV INCLUDED	EEV INCLUDED	EEV INCLUDED
Sound	Sound Pressure	High / Mid / Low	dB(A)	29 / 26 / 24	32 / 28 / 24	37 / 33 / 30
	Sound Power	Cooling		47	50	55
Dimension	Net Weight		kg	10	10	10
	Shipping Weight		kg	12.8	12.8	12.8
	Net Dimensions (WxHxD)		mm	970 x 135 x 410	970 x 135 x 410	970 x 135 x 410
	Shipping Dimensions (WxHxD)		mm	1,173 x 231 x 478	1,173 x 231 x 478	1,173 x 231 x 478

2. Specification

Wind free 1 Way Cassette

Type			1Way CASSETTE	1Way CASSETTE	1Way CASSETTE
Model Name			AM022NN1DEH/XX	AM028NN1DEH/XX	AM036NN1DEH/XX
Casing	Material	-	ABS	ABS	ABS
Panel	Model Name	-	PC1NWFMAN	PC1NWFMAN	PC1NWFMAN
	Type	-	Wind Free	Wind Free	Wind Free
	Material	-	HIPS	HIPS	HIPS
	Color	-	White	White	White
	Net Weight	kg	4.3	4.3	4.3
	Shipping Weight	kg	6.3	6.3	6.3
	Net Dimensions (W×H×D)	mm	1198 x 35 x 500	1198 x 35 x 500	1198 x 35 x 500
	Shipping Dimensions (W×H×D)	mm	1262 x 122 x 566	1262 x 122 x 566	1262 x 122 x 566
Drain pump		-	INCLUDED	INCLUDED	INCLUDED
	Max. lifting Height / Displacement	mm / Liter/h	750 / 24	750 / 24	750 / 24

NOTE

- Mode : HP(Heat Pump), HR(Heat Recovery)
- Cooling : Indoor temperature 27°C DB / 19°C WB, Outdoor temperature 35°C DB/24°C WB, Refrigerant pipe length 7.5m, Level difference 0m.
- Heating : Indoor temperature 20°C DB / 15°C WB, Outdoor temperature 7°C DB / 6°C WB, Refrigerant pipe length 7.5m, Level difference 0m.
- Sound level was acquired in an anechoic room. Thus actual noise level may be different depending on the installation conditions.
- These products contain R410A (GWP=2,088) which is fluorinated greenhouse gas.
- Specifications may be subject to change without prior notice.
- Select wire size based on the value of MCA
- Drain pump included (check valve included)

2. Specification

Wind free 1 Way Cassette

Type				1Way CASSETTE	1Way CASSETTE
Model Name				AM056NN1DEH/XX	AM071NN1DEH/XX
Power Supply			Φ, #, V, Hz	1,2,220-240,50	1,2,220-240,50
Mode			-	HP/HR	HP/HR
Performance	Capacity	Cooling	kW	5.60	7.10
			Btu/h	19,100	24,200
		Heating	kW	6.30	8.00
			Btu/h	21,500	27,300
Power	Power Input	Cooling	W	55.00	80.00
		Heating		55.00	80.00
	Current Input	Cooling	A	0.28	0.40
		Heating		0.28	0.40
	Current	MCA	A	0.35	0.50
		MFA		15	15
Heat exchanger	Type		-	Fin & Tube	Fin & Tube
	Material	Fin	-	Al	Al
		Tube	-	Cu	Cu
	Fin Treatment		-	Green Hydrophile	Green Hydrophile
Fan	Type		-	Crossflow Fan	Crossflow Fan
	Quantity		ea	1	1
	Air Flow Rate	H/M/L	m ³ /min	16.00/14.00/12.50	17.00/15.50/14.00
			l/s	266.67/233.33/208.33	283.33/258.33/233.33
Fan Motor	Model		-	BLDC Motor	BLDC Motor
	Output x n		W	54 x 1	54 x 1
Piping Connections	Liquid Pipe		Type	Flare Connection	Flare Connection
			Φ, mm	6.35	9.52
			Φ, inch	1/4"	3/8"
	Gas Pipe		Type	Flare Connection	Flare Connection
			Φ, mm	12.70	15.88
			Φ, inch	1/2"	5/8"
Drain Pipe		Φ, mm	VP20 (OD 25,ID 20)	VP20 (OD 25,ID 20)	
Wiring connections	Communication	Minimum	mm ²	0.75	0.75
		Remark	-	F1, F2	F1, F2
Refrigerant	Type		-	R410A	R410A
	Electronic Expansion Valve		-	EEV INCLUDED	EEV INCLUDED
Sound	Sound Pressure	High / Mid / Low	dB(A)	41 / 38 / 35	42 / 39 / 36
	Sound Power	Cooling		59	60
Dimension	Net Weight		kg	13.5	13.5
	Shipping Weight		kg	17.3	17.3
	Net Dimensions (WxHxD)		mm	1200 x 138 x 450	1200 x 138 x 450
	Shipping Dimensions (WxHxD)		mm	1435 x 224 x 525	1435 x 224 x 525

2. Specification

Wind free 1 Way Cassette

Type			1Way CASSETTE	1Way CASSETTE
Model Name			AM056NN1DEH/XX	AM071NN1DEH/XX
Casing	Material	-	ABS	ABS
Panel	Model Name	-	PC1BWFMAN	PC1BWFMAN
	Type	-	Wind Free	Wind Free
	Material	-	HIPS	HIPS
	Color	-	White	White
	Net Weight	kg	5.0	5.0
	Shipping Weight	kg	7.0	7.0
	Net Dimensions (W×H×D)	mm	1410 x 35 x 500	1410 x 35 x 500
	Shipping Dimensions (W×H×D)	mm	1474 x 122 x 566	1474 x 122 x 566
Drain pump		-	INCLUDED	INCLUDED
	Max. lifting Height / Displacement	mm / Liter/h	750 / 24	750 / 24

NOTE

- Mode : HP(Heat Pump), HR(Heat Recovery)
- Cooling : Indoor temperature 27°C DB / 19°C WB, Outdoor temperature 35°C DB/24°C WB, Refrigerant pipe length 7.5m, Level difference 0m.
- Heating : Indoor temperature 20°C DB / 15°C WB, Outdoor temperature 7°C DB / 6°C WB, Refrigerant pipe length 7.5m, Level difference 0m.
- Sound level was acquired in an anechoic room. Thus actual noise level may be different depending on the installation conditions.
- These products contain R410A (GWP=2,088) which is fluorinated greenhouse gas.
- Specifications may be subject to change without prior notice.
- Select wire size based on the value of MCA
- Drain pump included (check valve included)

3. Summary Table

Wind free 1 Way Cassette

Performance Characteristics

Model Code	Net Weight (kg)	Fan Speed	Nominal Capacity(kW)			Airflow (CMM)	Sound Pressure (dBA)	Sound Power (dBA)
			Cooling	Sensible	Heating			
AM017NN1PEH/**	8.0	High	1.70	1.20	1.90	4.80	28	46
		Mid	1.61	1.14	1.83	4.30	26	
		Low	1.49	1.05	1.70	4.10	24	
		W/Free	1.00	0.70	-	2.00	24	
AM022NN1PEH/**	8.0	High	2.20	1.50	2.50	5.10	29	47
		Mid	2.09	1.43	2.37	4.60	26	
		Low	1.92	1.31	2.15	4.30	24	
		W/Free	1.20	0.90	-	2.00	24	
AM022NN1DEH/**	10.0	High	2.20	1.50	2.50	6.00	29	47
		Mid	2.01	1.37	2.37	5.00	26	
		Low	1.64	1.12	2.15	4.00	24	
		W/Free	1.10	0.80	-	3.00	24	
AM028NN1DEH/**	10.0	High	2.80	1.90	3.20	7.00	32	50
		Mid	2.59	1.76	2.99	6.00	28	
		Low	2.19	1.49	2.59	5.00	24	
		W/Free	1.40	1.00	-	3.20	24	
AM036NN1DEH/**	10.0	High	3.60	2.60	4.00	8.00	37	55
		Mid	3.37	2.43	3.78	7.00	33	
		Low	2.92	2.11	3.40	6.00	30	
		W/Free	1.90	1.30	-	3.60	30	
AM056NN1DEH/**	13.5	High	5.60	4.20	6.30	16.00	41	59
		Mid	5.24	3.93	6.07	14.00	38	
		Low	4.63	3.47	5.60	12.50	35	
		W/Free	3.00	2.10	-	6.00	30	
AM071NN1DEH/**	13.5	High	7.10	5.00	8.00	17.00	42	60
		Mid	6.78	4.77	7.71	15.50	39	
		Low	6.15	4.33	7.14	14.00	36	
		W/Free	4.00	2.80	-	6.50	30	

NOTE

- Sound data is based on cooling operation.

Electrical Characteristics

Model Code	Power Supply (Φ, #, V, Hz)	Power Input (W)	Current Input (A)	MCA (A)	MFA (A)	FLA (A)
AM017NN1PEH/**	1,2,220-240,50	24.00	0.14	0.18	15	0.14
AM022NN1PEH/**	1,2,220-240,50	25.00	0.15	0.19	15	0.15
AM022NN1DEH/**	1,2,220-240,50	40.00	0.20	0.25	15	0.20
AM028NN1DEH/**	1,2,220-240,50	45.00	0.23	0.29	15	0.23
AM036NN1DEH/**	1,2,220-240,50	50.00	0.25	0.31	15	0.25
AM056NN1DEH/**	1,2,220-240,50	55.00	0.28	0.35	15	0.28
AM071NN1DEH/**	1,2,220-240,50	80.00	0.40	0.50	15	0.40

NOTE

- MCA: Minimum circuit amperes
- MFA: Maximum fuse amperes
- FLA: Full load amperes
- Select wire size based on the value of MCA

4. Capacity Table

Wind-Free 1Way Cassette

Model	Outdoor temperature (°C, DB)	Indoor temperature (°C, WB)													
		14.0		16.0		18.0		19.0		20.0		22.0		24.0	
		TC	SHC	TC	SHC	TC	SHC	TC	SHC	TC	SHC	TC	SHC	TC	SHC
		kW	kW	kW	kW	kW	kW	kW	kW	kW	kW	kW	kW	kW	kW
3.60	10	2.50	2.20	2.90	2.40	3.40	2.40	3.60	2.60	3.70	2.60	4.00	2.60	4.30	2.50
	12	2.50	2.20	2.90	2.40	3.40	2.40	3.60	2.60	3.70	2.60	4.00	2.60	4.30	2.50
	14	2.50	2.20	2.90	2.40	3.40	2.40	3.60	2.60	3.70	2.60	4.00	2.60	4.30	2.50
	16	2.50	2.20	2.90	2.40	3.40	2.40	3.60	2.60	3.70	2.60	4.00	2.60	4.30	2.50
	18	2.50	2.20	2.90	2.40	3.40	2.40	3.60	2.60	3.70	2.60	4.00	2.60	4.30	2.50
	20	2.50	2.20	2.90	2.40	3.40	2.40	3.60	2.60	3.70	2.60	4.00	2.60	4.20	2.40
	21	2.50	2.20	2.90	2.40	3.40	2.40	3.60	2.60	3.70	2.60	4.00	2.60	4.20	2.40
	23	2.50	2.20	2.90	2.40	3.40	2.40	3.60	2.60	3.70	2.60	4.00	2.60	4.20	2.40
	25	2.50	2.20	2.90	2.40	3.40	2.40	3.60	2.60	3.70	2.60	4.00	2.60	4.20	2.40
	27	2.50	2.20	2.90	2.40	3.40	2.40	3.60	2.60	3.70	2.60	4.00	2.60	4.20	2.40
	29	2.50	2.20	2.90	2.40	3.40	2.40	3.60	2.60	3.70	2.60	4.00	2.60	4.20	2.40
	31	2.50	2.20	2.90	2.40	3.40	2.40	3.60	2.60	3.70	2.60	4.00	2.60	4.20	2.40
	33	2.50	2.20	2.90	2.40	3.40	2.40	3.60	2.60	3.70	2.60	4.00	2.60	4.20	2.40
	35	2.50	2.20	2.90	2.40	3.40	2.40	3.60	2.60	3.70	2.60	4.00	2.60	4.20	2.40
37	2.50	2.20	2.90	2.40	3.40	2.40	3.60	2.60	3.70	2.60	3.90	2.50	4.20	2.40	
39	2.50	2.20	2.90	2.40	3.40	2.40	3.60	2.60	3.70	2.60	3.90	2.50	4.10	2.30	
5.60	10	3.90	3.30	4.60	3.80	5.30	4.10	5.60	4.20	5.80	4.20	6.30	4.30	6.70	4.10
	12	3.90	3.30	4.60	3.80	5.30	4.10	5.60	4.20	5.80	4.20	6.30	4.30	6.70	4.10
	14	3.90	3.30	4.60	3.80	5.30	4.10	5.60	4.20	5.80	4.20	6.20	4.20	6.70	4.00
	16	3.90	3.30	4.60	3.80	5.30	4.10	5.60	4.20	5.80	4.20	6.20	4.20	6.60	4.00
	18	3.90	3.30	4.60	3.80	5.30	4.10	5.60	4.20	5.80	4.20	6.20	4.20	6.60	4.00
	20	3.90	3.30	4.60	3.80	5.30	4.10	5.60	4.20	5.80	4.20	6.20	4.20	6.60	4.00
	21	3.90	3.30	4.60	3.80	5.30	4.10	5.60	4.20	5.80	4.20	6.20	4.20	6.60	4.00
	23	3.90	3.30	4.60	3.80	5.30	4.10	5.60	4.20	5.80	4.20	6.20	4.20	6.60	4.00
	25	3.90	3.30	4.60	3.80	5.30	4.10	5.60	4.20	5.80	4.20	6.20	4.20	6.60	4.00
	27	3.90	3.30	4.60	3.80	5.30	4.10	5.60	4.20	5.80	4.20	6.20	4.20	6.60	4.00
	29	3.90	3.30	4.60	3.80	5.30	4.10	5.60	4.20	5.80	4.20	6.20	4.20	6.60	4.00
	31	3.90	3.30	4.60	3.80	5.30	4.10	5.60	4.20	5.80	4.20	6.20	4.20	6.60	4.00
	33	3.90	3.30	4.60	3.80	5.30	4.10	5.60	4.20	5.80	4.20	6.20	4.20	6.60	4.00
	35	3.90	3.30	4.60	3.80	5.30	4.10	5.60	4.20	5.80	4.20	6.20	4.20	6.60	4.00
37	3.90	3.30	4.60	3.80	5.30	4.10	5.60	4.20	5.80	4.20	6.10	4.10	6.50	3.90	
39	3.90	3.30	4.60	3.80	5.30	4.10	5.60	4.20	5.80	4.20	6.10	4.10	6.40	3.80	
7.10	10	4.90	4.00	5.80	4.50	6.70	4.80	7.10	5.00	7.40	5.00	8.00	5.10	8.50	4.80
	12	4.90	4.00	5.80	4.50	6.70	4.80	7.10	5.00	7.40	5.00	7.90	5.00	8.50	4.80
	14	4.90	4.00	5.80	4.50	6.70	4.80	7.10	5.00	7.40	5.00	7.90	5.00	8.50	4.80
	16	4.90	4.00	5.80	4.50	6.70	4.80	7.10	5.00	7.40	5.00	7.90	5.00	8.40	4.80
	18	4.90	4.00	5.80	4.50	6.70	4.80	7.10	5.00	7.40	5.00	7.90	5.00	8.40	4.80
	20	4.90	4.00	5.80	4.50	6.70	4.80	7.10	5.00	7.40	5.00	7.90	5.00	8.40	4.80
	21	4.90	4.00	5.80	4.50	6.70	4.80	7.10	5.00	7.40	5.00	7.90	5.00	8.40	4.80
	23	4.90	4.00	5.80	4.50	6.70	4.80	7.10	5.00	7.40	5.00	7.90	5.00	8.40	4.80
	25	4.90	4.00	5.80	4.50	6.70	4.80	7.10	5.00	7.40	5.00	7.90	5.00	8.40	4.80
	27	4.90	4.00	5.80	4.50	6.70	4.80	7.10	5.00	7.40	5.00	7.90	5.00	8.40	4.80
	29	4.90	4.00	5.80	4.50	6.70	4.80	7.10	5.00	7.40	5.00	7.90	5.00	8.40	4.80
	31	4.90	4.00	5.80	4.50	6.70	4.80	7.10	5.00	7.40	5.00	7.90	5.00	8.40	4.80
	33	4.90	4.00	5.80	4.50	6.70	4.80	7.10	5.00	7.40	5.00	7.90	5.00	8.40	4.80
	35	4.90	4.00	5.80	4.50	6.70	4.80	7.10	5.00	7.40	5.00	7.90	5.00	8.40	4.80
37	4.90	4.00	5.80	4.50	6.70	4.80	7.10	5.00	7.30	4.90	7.80	4.90	8.20	4.70	
39	4.90	4.00	5.80	4.50	6.70	4.80	7.10	5.00	7.30	4.90	7.70	4.80	8.10	4.60	

NOTE

- The performance table shows the average value of each conditions.

4. Capacity Table

Wind-Free 1Way Cassette

Heating

TC : Total Capacity (kW)

Model	Outdoor temperature (°C, DB)		Indoor temperature (°C, DB)				
			16.0	18.0	20.0	22.0	24.0
	DB	WB	TC kW	TC kW	TC kW	TC kW	TC kW
1.70	-20	-21	1.10	1.10	1.10	1.10	1.10
	-17	-18	1.20	1.20	1.20	1.20	1.20
	-15	-16	1.30	1.20	1.20	1.20	1.20
	-12	-13	1.40	1.40	1.40	1.40	1.30
	-10	-11	1.50	1.50	1.40	1.40	1.40
	-7	-8	1.70	1.70	1.70	1.50	1.50
	-5	-6	1.80	1.70	1.70	1.70	1.70
	-3	-4	1.90	1.90	1.80	1.70	1.70
	0	-1	2.00	1.90	1.90	1.70	1.70
	3	2	2.10	2.00	1.90	1.70	1.70
	5	4	2.10	2.10	1.90	1.70	1.70
	7	6	2.10	2.10	1.90	1.70	1.70
	9	8	2.30	2.10	1.90	1.70	1.70
	11	10	2.30	2.10	1.90	1.70	1.70
	13	12	2.30	2.10	1.90	1.70	1.70
15	14	2.30	2.10	1.90	1.70	1.70	
2.20 (Small)	-20	-21	1.50	1.50	1.50	1.50	1.50
	-17	-18	1.60	1.60	1.60	1.60	1.60
	-15	-16	1.70	1.60	1.60	1.60	1.60
	-12	-13	1.80	1.80	1.80	1.80	1.70
	-10	-11	2.00	2.00	1.90	1.90	1.90
	-7	-8	2.30	2.20	2.20	2.00	2.00
	-5	-6	2.40	2.30	2.30	2.20	2.20
	-3	-4	2.50	2.50	2.40	2.30	2.20
	0	-1	2.60	2.50	2.50	2.30	2.20
	3	2	2.70	2.60	2.50	2.30	2.20
	5	4	2.80	2.70	2.50	2.30	2.20
	7	6	2.80	2.70	2.50	2.30	2.20
	9	8	3.00	2.70	2.50	2.30	2.20
	11	10	3.00	2.70	2.50	2.30	2.20
	13	12	3.00	2.70	2.50	2.30	2.20
15	14	3.00	2.70	2.50	2.30	2.20	
2.20 (Middle)	-20	-21	1.50	1.50	1.50	1.50	1.50
	-17	-18	1.60	1.60	1.60	1.60	1.60
	-15	-16	1.70	1.60	1.60	1.60	1.60
	-12	-13	1.80	1.80	1.80	1.80	1.70
	-10	-11	2.00	2.00	1.90	1.90	1.90
	-7	-8	2.30	2.20	2.20	2.00	2.00
	-5	-6	2.40	2.30	2.30	2.20	2.20
	-3	-4	2.50	2.50	2.40	2.30	2.20
	0	-1	2.60	2.50	2.50	2.30	2.20
	3	2	2.70	2.60	2.50	2.30	2.20
	5	4	2.80	2.70	2.50	2.30	2.20
	7	6	2.80	2.70	2.50	2.30	2.20
	9	8	3.00	2.70	2.50	2.30	2.20
	11	10	3.00	2.70	2.50	2.30	2.20
	13	12	3.00	2.70	2.50	2.30	2.20
15	14	3.00	2.70	2.50	2.30	2.20	
2.80	-20	-21	1.90	1.90	1.90	1.90	1.90
	-17	-18	2.00	2.00	2.00	2.00	1.90
	-15	-16	2.10	2.10	2.00	2.00	1.90
	-12	-13	2.20	2.20	2.20	2.10	2.10
	-10	-11	2.30	2.30	2.30	2.30	2.20
	-7	-8	2.50	2.40	2.40	2.40	2.30
	-5	-6	2.60	2.60	2.50	2.50	2.40
	-3	-4	2.80	2.70	2.70	2.60	2.50
	0	-1	2.90	2.80	2.80	2.70	2.60
	3	2	3.00	3.00	2.90	2.80	2.70
	5	4	3.20	3.10	3.10	2.90	2.70
	7	6	3.30	3.20	3.20	3.00	2.70
	9	8	3.40	3.30	3.20	3.00	2.70
	11	10	3.50	3.30	3.20	3.00	2.70
	13	12	3.60	3.40	3.20	3.00	2.70
15	14	3.70	3.40	3.20	3.00	2.70	

4. Capacity Table

Wind-Free 1Way Cassette

Model	Outdoor temperature (°C, DB)		Indoor temperature (°C, DB)				
			16.0	18.0	20.0	22.0	24.0
	DB	WB	TC kW	TC kW	TC kW	TC kW	TC kW
3.60	-20	-21	2.40	2.40	2.30	2.30	2.30
	-17	-18	2.60	2.50	2.40	2.40	2.30
	-15	-16	2.70	2.60	2.50	2.50	2.40
	-12	-13	2.80	2.70	2.70	2.60	2.60
	-10	-11	2.90	2.90	2.90	2.80	2.80
	-7	-8	3.10	3.10	3.00	3.00	2.90
	-5	-6	3.30	3.20	3.20	3.10	3.00
	-3	-4	3.40	3.40	3.30	3.20	3.10
	0	-1	3.60	3.60	3.50	3.40	3.20
	3	2	3.80	3.70	3.70	3.50	3.40
	5	4	3.90	3.90	3.80	3.60	3.40
	7	6	4.10	4.10	4.00	3.70	3.40
	9	8	4.20	4.10	4.00	3.70	3.40
	11	10	4.40	4.20	4.00	3.70	3.40
	13	12	4.50	4.20	4.00	3.70	3.40
15	14	4.60	4.30	4.00	3.70	3.40	
5.60	-20	-21	3.90	3.80	3.80	3.70	3.70
	-17	-18	4.00	4.00	3.90	3.80	3.80
	-15	-16	4.20	4.10	4.00	3.90	3.80
	-12	-13	4.40	4.30	4.20	4.20	4.10
	-10	-11	4.60	4.60	4.50	4.40	4.40
	-7	-8	4.90	4.80	4.80	4.70	4.50
	-5	-6	5.20	5.10	5.00	4.90	4.70
	-3	-4	5.40	5.30	5.30	5.10	4.90
	0	-1	5.70	5.60	5.50	5.30	5.00
	3	2	5.90	5.90	5.80	5.60	5.30
	5	4	6.20	6.10	6.00	5.70	5.30
	7	6	6.50	6.40	6.30	5.80	5.30
	9	8	6.70	6.50	6.30	5.80	5.30
	11	10	6.90	6.60	6.30	5.80	5.30
	13	12	7.10	6.70	6.30	5.80	5.30
15	14	7.30	6.80	6.30	5.80	5.30	
7.10	-20	-21	4.90	4.90	4.80	4.70	4.70
	-17	-18	5.10	5.00	4.90	4.80	4.80
	-15	-16	5.30	5.20	5.10	4.90	4.80
	-12	-13	5.60	5.50	5.40	5.30	5.20
	-10	-11	5.90	5.80	5.70	5.60	5.60
	-7	-8	6.20	6.10	6.00	5.90	5.80
	-5	-6	6.50	6.50	6.40	6.20	6.00
	-3	-4	6.90	6.80	6.70	6.40	6.20
	0	-1	7.20	7.10	7.00	6.70	6.40
	3	2	7.60	7.50	7.30	7.10	6.80
	5	4	7.90	7.80	7.70	7.20	6.80
	7	6	8.20	8.10	8.00	7.40	6.80
	9	8	8.50	8.20	8.00	7.40	6.80
	11	10	8.70	8.40	8.00	7.40	6.80
	13	12	9.00	8.50	8.00	7.40	6.80
15	14	9.20	8.60	8.00	7.40	6.80	

 **NOTE**

- The performance table shows the average value of each conditions.

5. Dimensional Drawing

Wind-Free 1Way Cassette

• AM017/022NN1PEH/××

(Unit: mm)

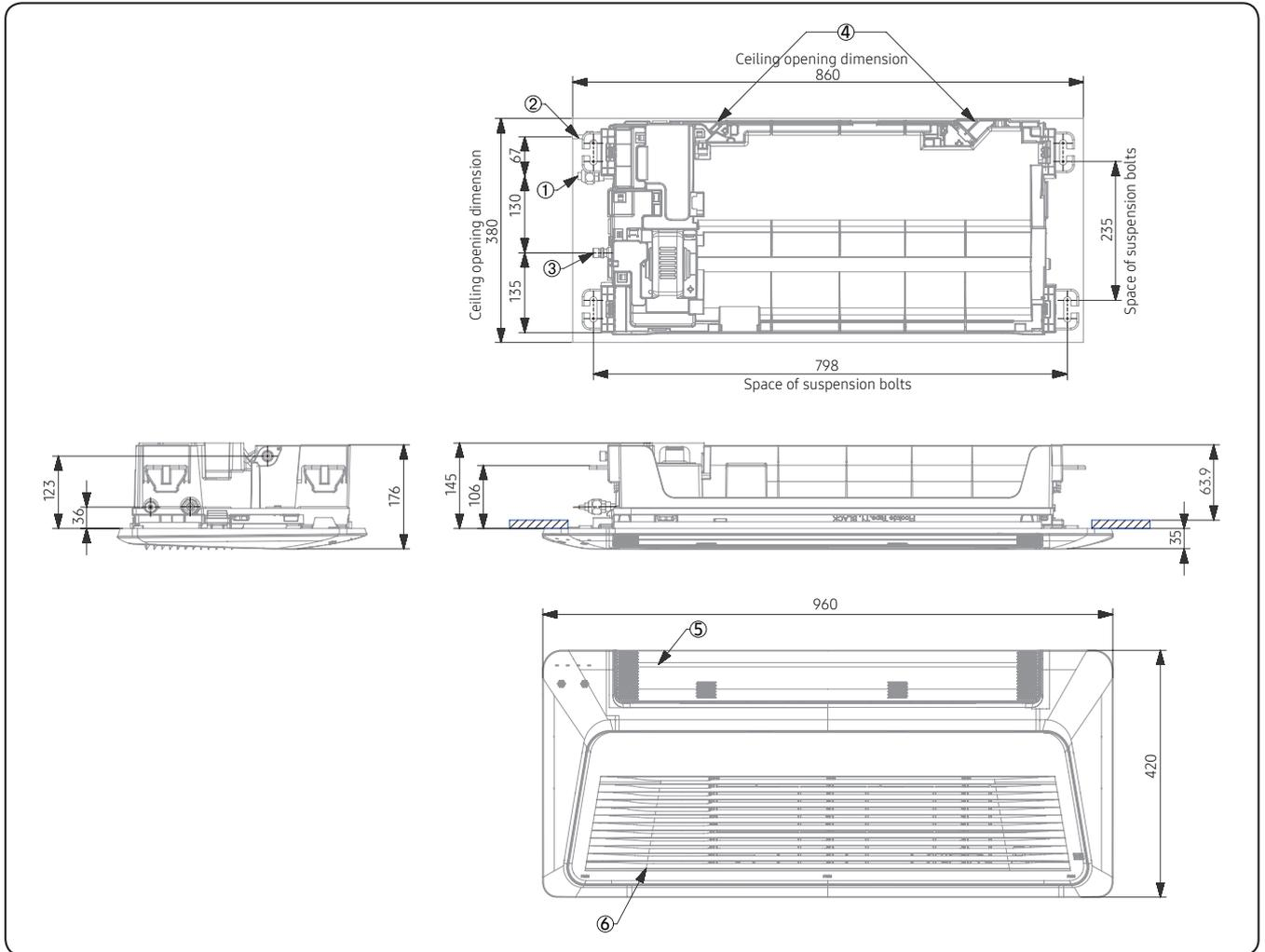

NO	Name	Description	NO	Name	Description
01	Gas pipe connection	Ø9.52 (3/8")	05	Air outlet louver	-
02	Liquid pipe connection	Ø6.35 (1/4")	06	Air inlet grille	-
03	Drain hose connection	VP20 (OD26, ID20)			
04	Power supply/Communication wiring conduit	-			

5. Dimensional Drawing

Wind-Free 1Way Cassette

• AM022/028/036NN1DEH/✕✕

(Unit: mm)

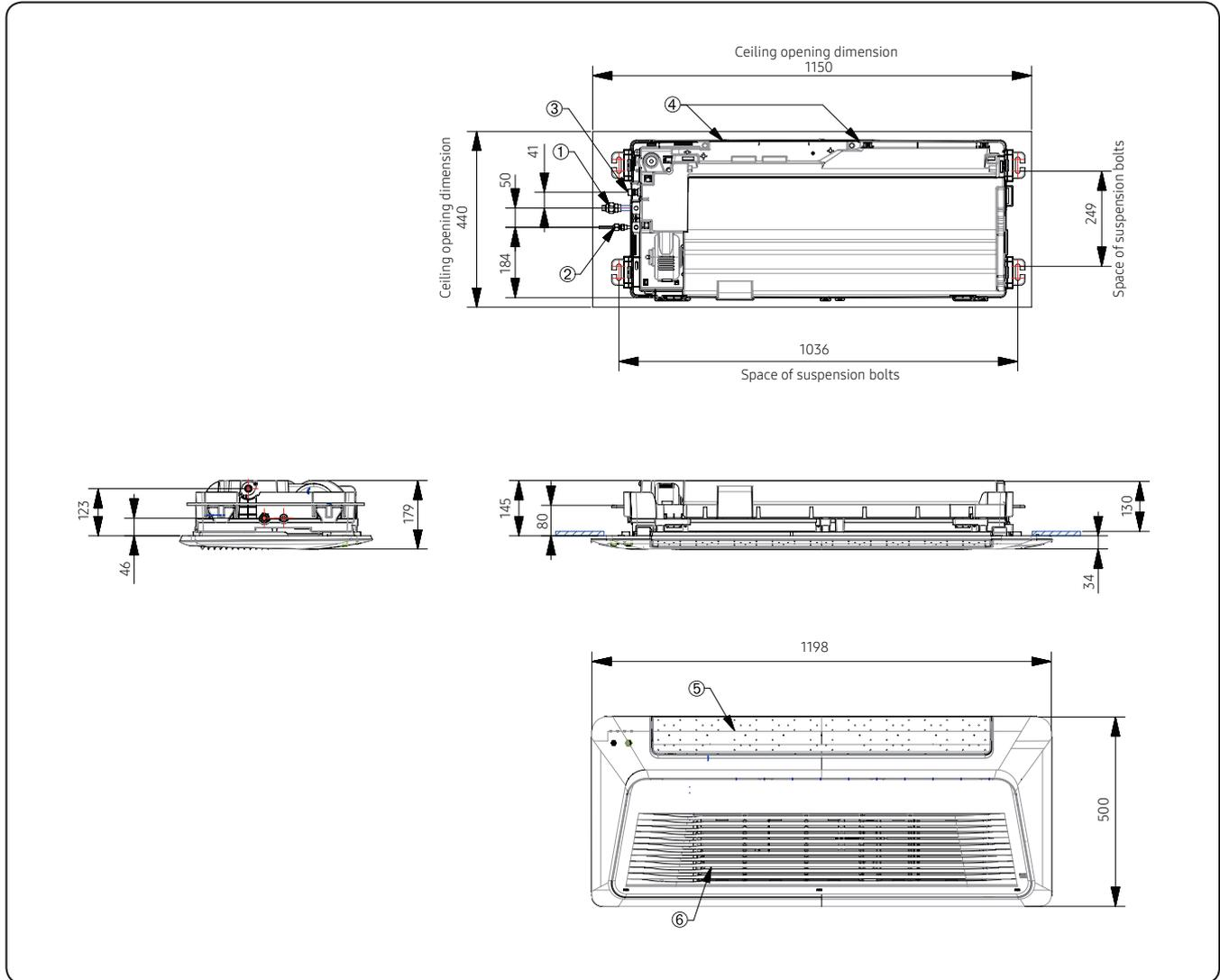

NO	Name	Description	NO	Name	Description
01	Gas pipe connection	Ø12.7 (1/2")	05	Air outlet louver	-
02	Liquid pipe connection	Ø6.35 (1/4")	06	Air inlet grille	-
03	Drain hose connection	VP20 (OD26, ID20)			
04	Power supply/Communication wiring conduit	-			

5. Dimensional Drawing

Wind-Free 1Way Cassette

• AM056/071NN1DEH/✕✕

(Unit: mm)

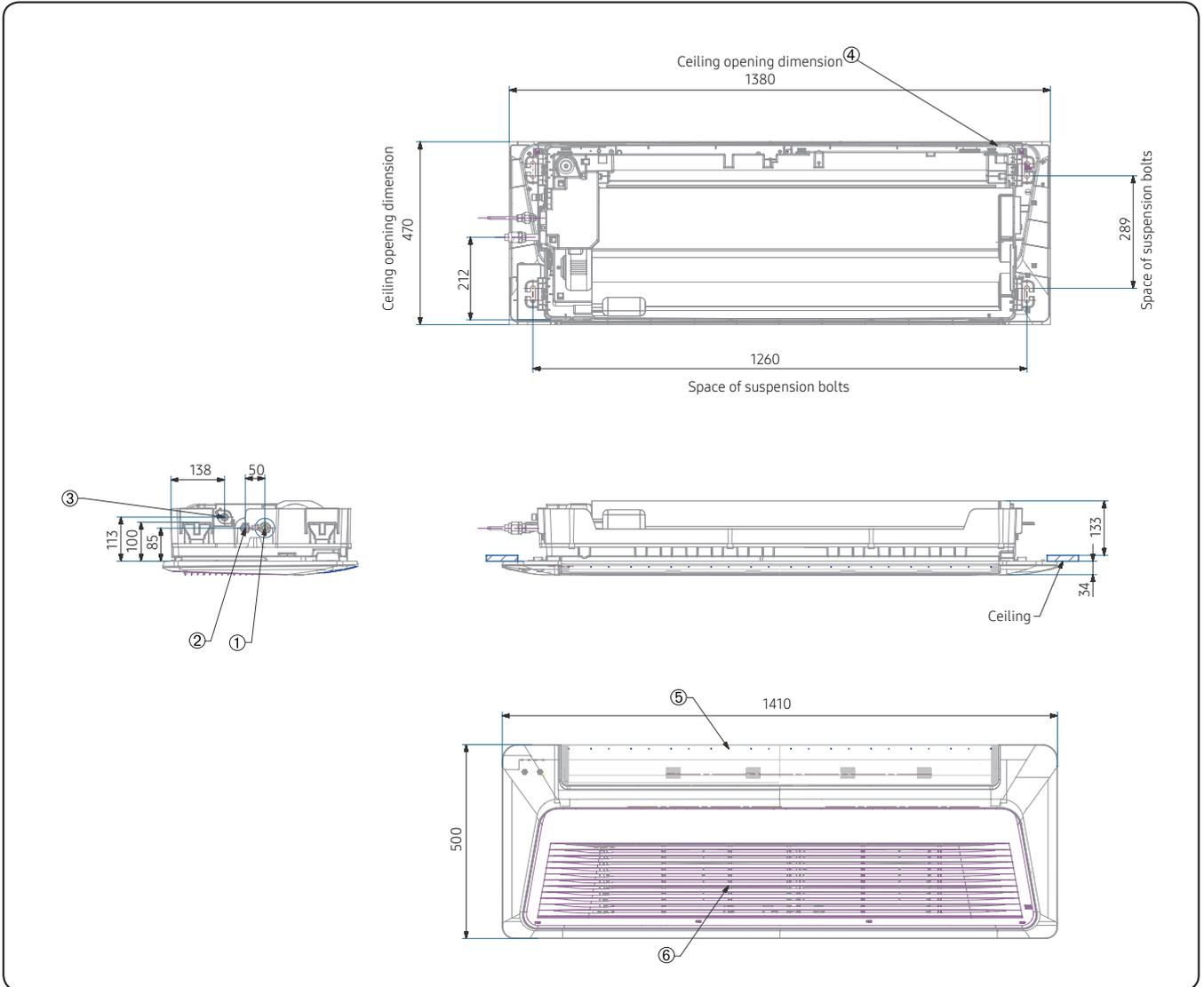

NO	Name	Description	NO	Name	Description
01	Gas pipe connection	5.2 kW	03	Drain hose connection	V25 (OD32, ID25)
		7.1 kW	04	Power supply/Communication wiring conduit	-
02	Liquid pipe connection	5.2 kW	05	Air outlet louver	-
		7.1 kW	06	Air inlet grille	-

6. Center of Gravity

Wind-Free 1Way Cassette

(Unit: mm)

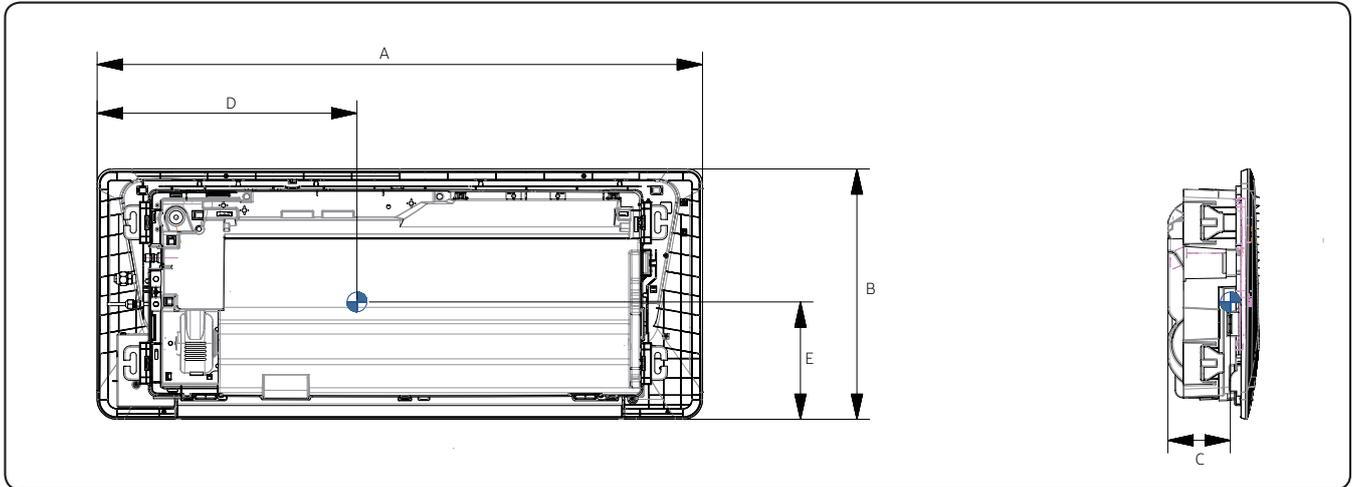

Model	A	B	C	D	E
AM017NN1PEH/** AM022NN1PEH/**	960	420	108	465	160
AM022NN1DEH/** AM028NN1DEH/** AM036NN1DEH/**	1,198	500	108	555	200
AM056NN1DEH/** AM071NN1DEH/**	1,410	500	108	755	200

7. Electrical Wiring Diagram

Wind-Free 1Way Cassette

- AM022/028/036NN1DEH/XX

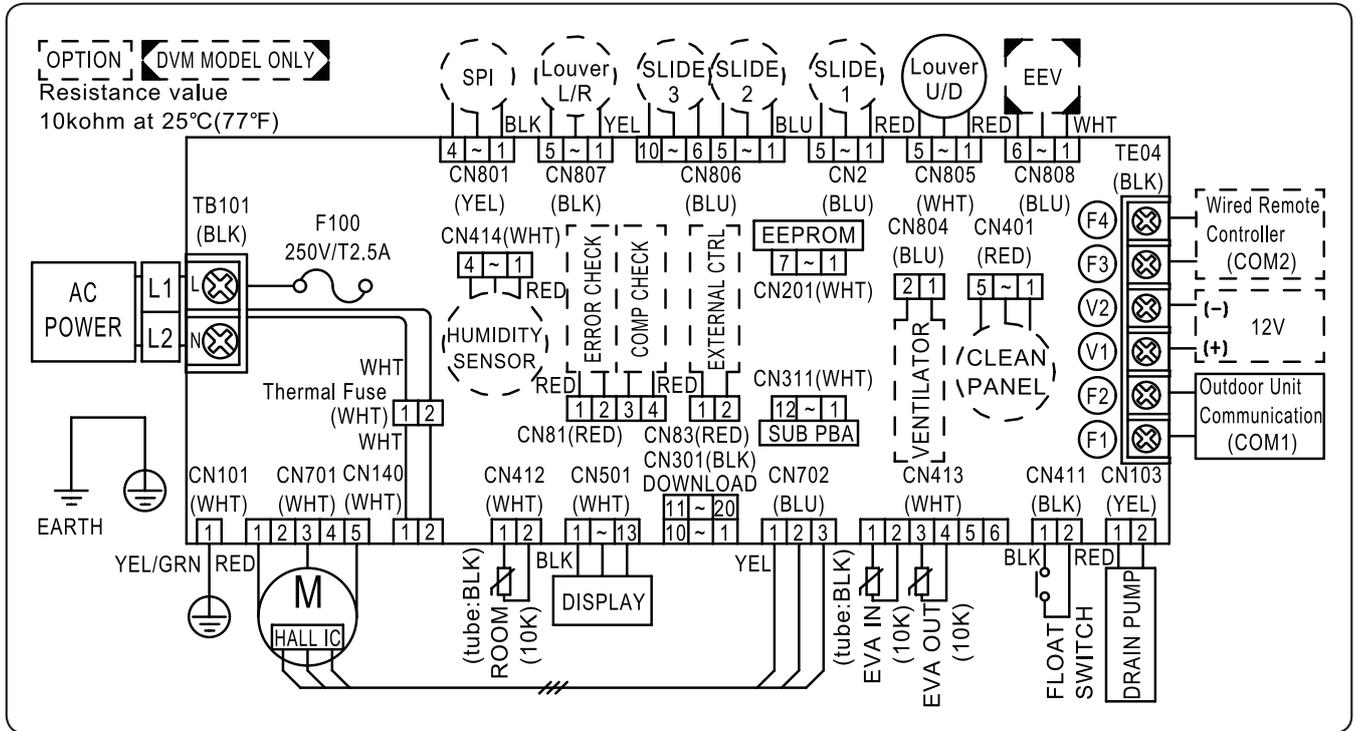

F100	FUSE	EEV	Electronic expansion valve	EVA-IN(10K)	Thermistor EVA IN(10K)
M[HALL IC]	Motor (IDU fan)	SPI	S-Plasma ion	EVA-OUT(10K)	Thermistor EVA OUT(10K)
Thermal Fuse	Terminal Block thermal fuse	ROOM(10K)	Thermistor ROOM(10K)		

NOTE

- This wiring diagram applies only to the indoor unit.
- Symbols show as follow :
BLK: black, RED: red, BLU: blue, WHT: white, YEL: yellow, BRN: brown, SKY: sky blue, GRN: green
- For connection wiring indoor-outdoor transmission F1-F2, indoor-wired remote controller transmission F3-F4.
- ⊕ Protective earth(SCREW)

7. Electrical Wiring Diagram

Wind-Free 1Way Cassette

- AM017/022NN1PEH/**, AM056/071NN1DEH/**

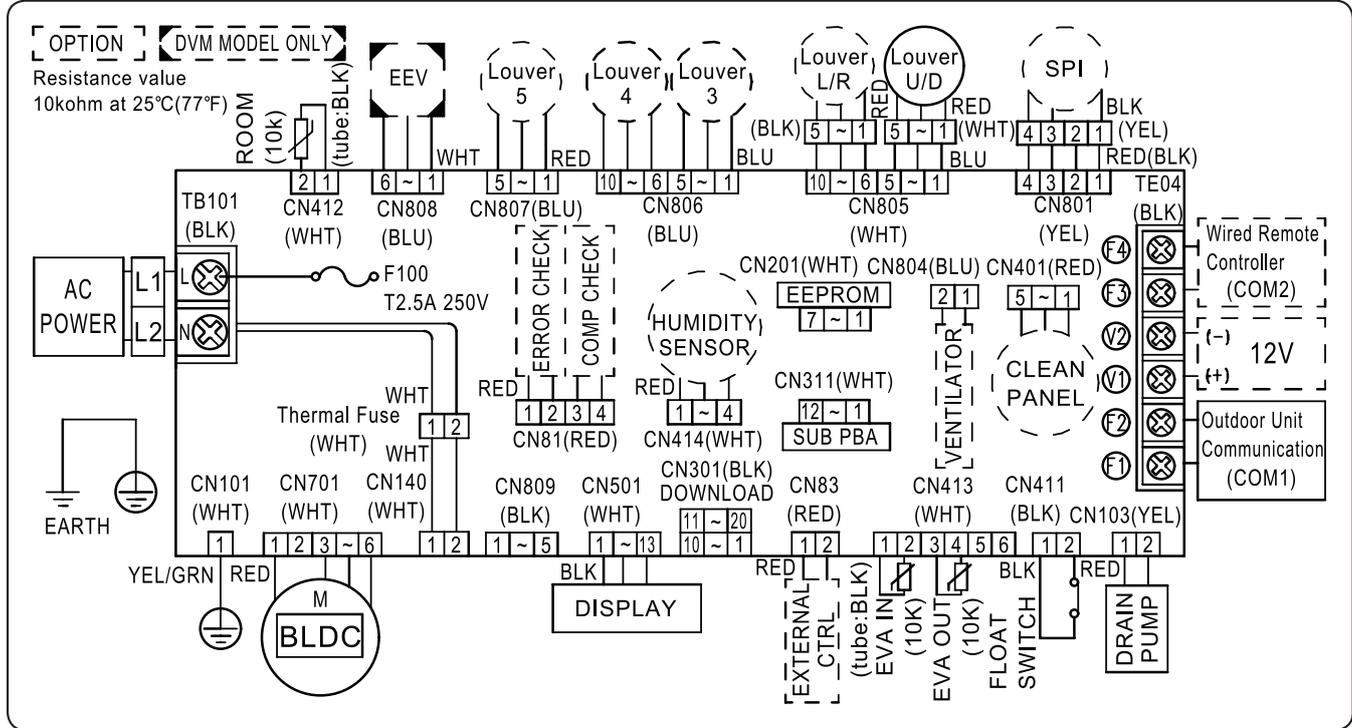

F100	FUSE	EEV	Electronic expansion valve	EVA-IN(10K)	Thermistor EVA IN(10K)
M[HALL IC]	Motor (IDU fan)	SPI	S-Plasma ion	EVA-OUT(10K)	Thermistor EVA OUT(10K)
Thermal Fuse	Terminal Block thermal fuse	ROOM(10K)	Thermistor ROOM(10K)		

NOTE

- This wiring diagram applies only to the indoor unit.
- Symbols show as follow :
BLK: black, RED: red, BLU: blue, WHT: white, YEL: yellow, BRN: brown, SKY: sky blue, GRN: green
- For connection wiring indoor-outdoor transmission F1-F2, indoor-wired remote controller transmission F3-F4.
- ⊕ Protective earth(SCREW)

8. Sound data

Wind-Free 1Way Cassette

Sound Pressure level

Unit: dB(A)

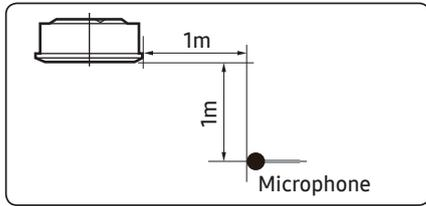

Model	High	Mid	Low
AM017NN1PEH/XX	28	26	24
AM022NN1PEH/XX	29	26	24
AM022NN1DEH/XX	29	26	24
AM028NN1DEH/XX	32	28	24

- NR Curve

1) AM017NN1PEH/XX

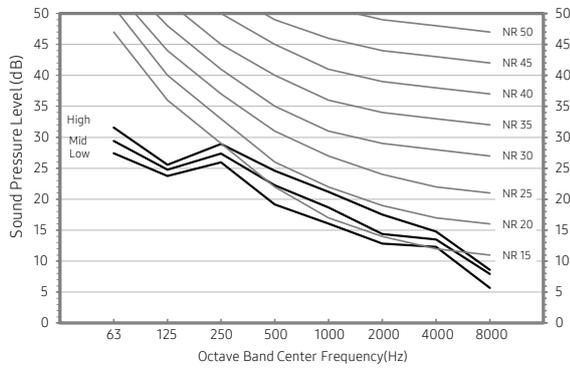

2) AM022NN1PEH/XX

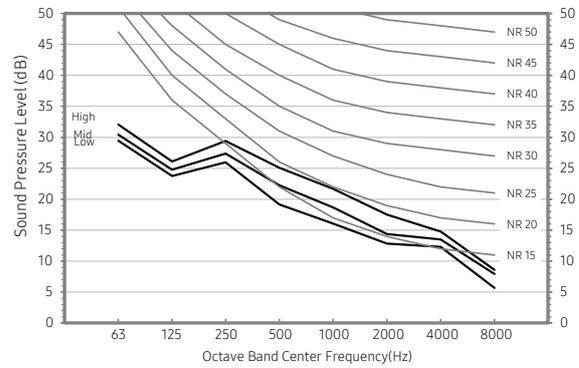

3) AM022NN1DEH

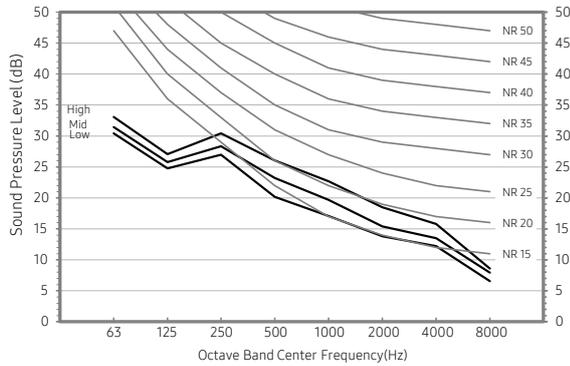

4) AM028NN1DEH

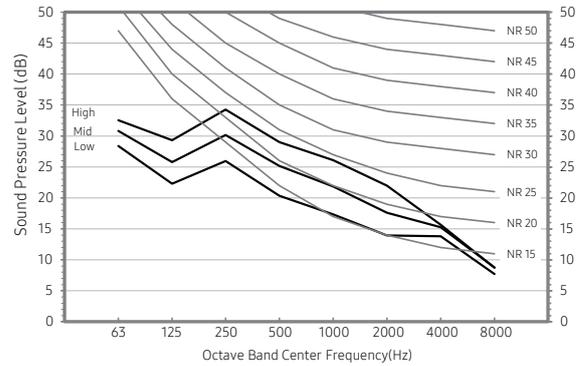

NOTE

- Specifications may be subject to change without prior notice.
 - Sound pressure level is obtained in an anechoic room.
 - Sound pressure level is a relative value, depending on the distance and acoustic environment.
 - Sound pressure level may differ depending on operation condition.
 - dBA = A weighted sound pressure level
 - Reference acoustic pressure 0 dB = 20μPa

8. Sound data

Wind-Free 1Way Cassette

Sound Pressure level

Unit: dB(A)

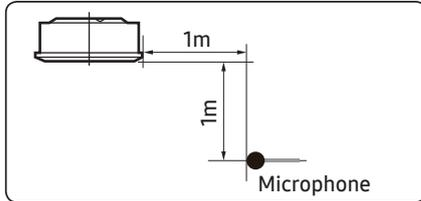

Model	High	Mid	Low
AM036NN1DEH/XX	37	33	30
AM056NN1DEH/XX	41	38	35
AM071NN1DEH/XX	42	39	36

- NR Curve

1) AM036NN1DEH/XX

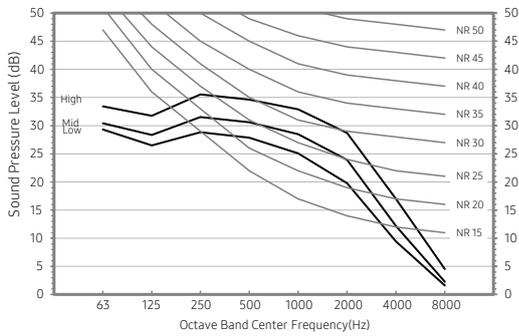

2) AM056NN1DEH/XX

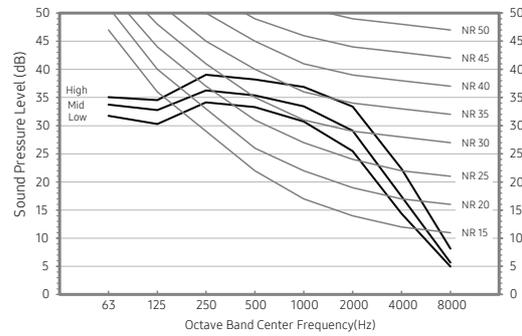

3) AM071NN1DEH/XX

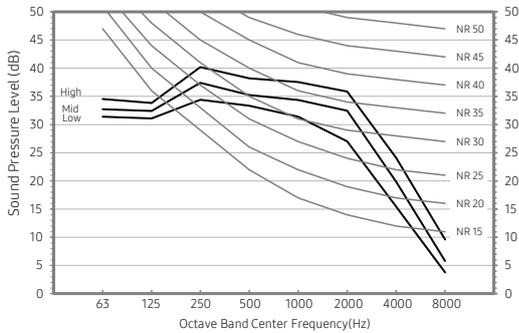

NOTE

- Specifications may be subject to change without prior notice.
 - Sound pressure level is obtained in an anechoic room.
 - Sound pressure level is a relative value, depending on the distance and acoustic environment.
 - Sound pressure level may differ depending on operation condition.
 - dBA = A weighted sound pressure level
 - Reference acoustic pressure 0 dB = 20μPa

8. Sound data

Wind-Free 1Way Cassette

Sound Power level

Unit: dB(A)

NOTE

- Specifications may be subject to change without prior notice
 - Sound power level is an absolute value that a sound source generates.
 - dB(A) = A-weighted sound power level.
 - Reference power : 1pW.
 - Measured according to ISO 3741.

Model	High
AM017NN1PEH/XX	46
AM022NN1PEH/XX	47
AM022NN1DEH/XX	47
AM028NN1DEH/XX	50

• NR Curve

1) AM017NN1PEH/XX

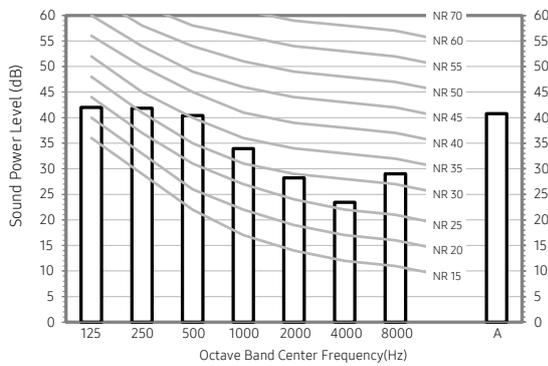

2) AM022NN1PEH/XX

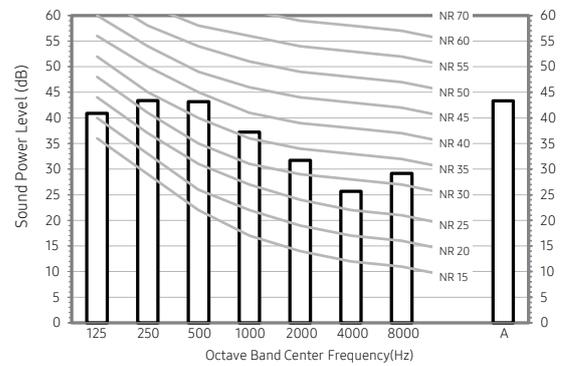

3) AM022NN1DEH/XX

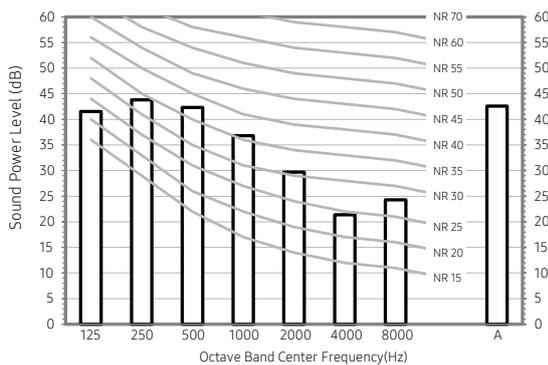

4) AM028NN1DEH/XX

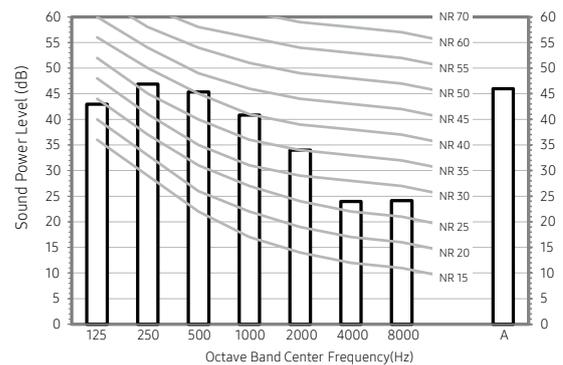

8. Sound data

Wind-Free 1Way Cassette

Sound Power level

Unit: dB(A)

NOTE

- Specifications may be subject to change without prior notice
 - Sound power level is an absolute value that a sound source generates.
 - dB(A) = A-weighted sound power level.
 - Reference power : 1pW.
 - Measured according to ISO 3741.

Model	High
AM036NN1DEH/XX	55
AM056NN1DEH/XX	59
AM071NN1DEH/XX	60

NR Curve

5) AM036NN1DEH/XX

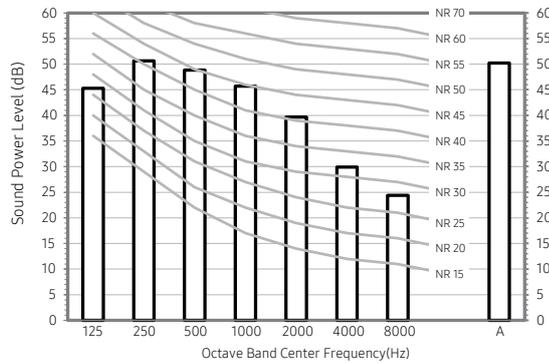

6) AM056NN1DEH/XX

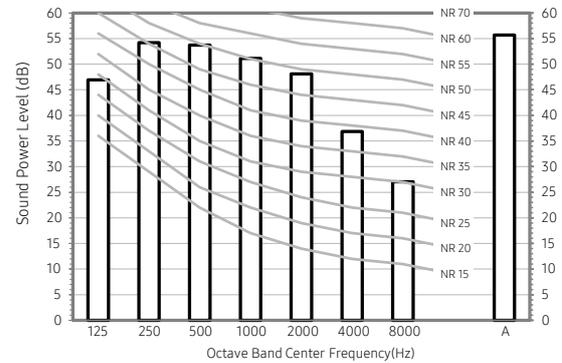

7) AM071NN1DEH/XX

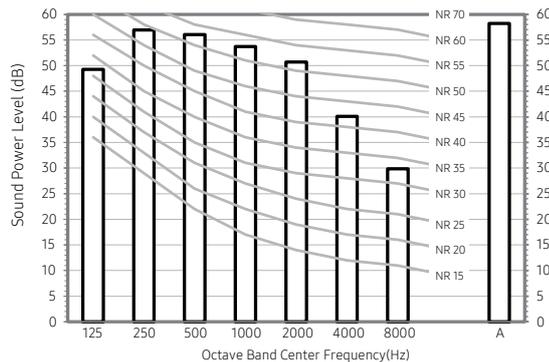

9. Temperature and Air Flow Distribution

Wind-Free 1Way Cassette

- AM017NN1PEH/××

Cooling Air Velocity distribution Discharge angle : 60°

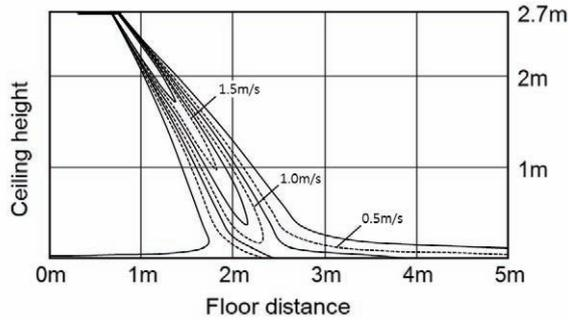

Cooling temperature distribution Discharge angle : 60°

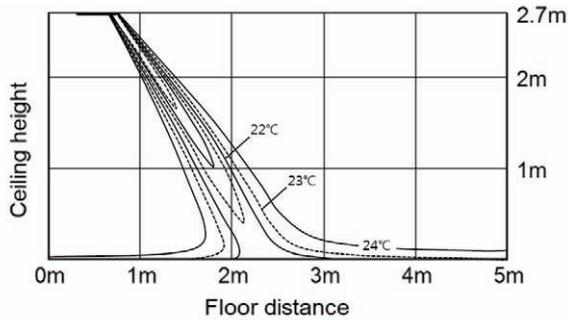

Heating Air Velocity distribution Discharge angle : 60°

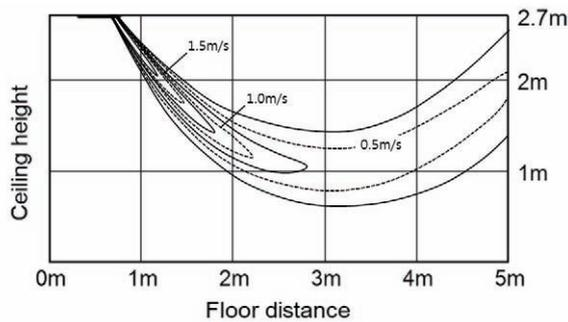

Heating temperature distribution Discharge angle : 60°

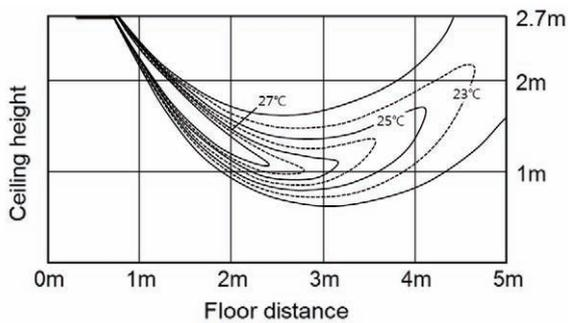

9. Temperature and Air Flow Distribution

Wind-Free 1Way Cassette

- AM022NN1PEH/XX

Cooling Air Velocity distribution Discharge angle : 60°

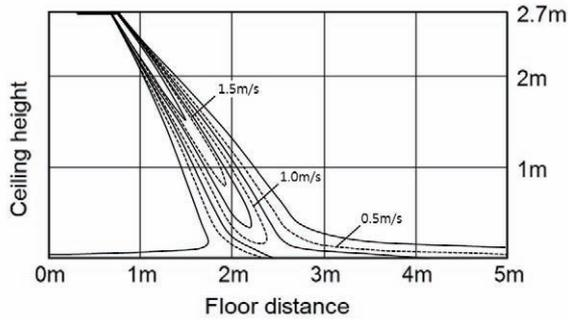

Cooling temperature distribution Discharge angle : 60°

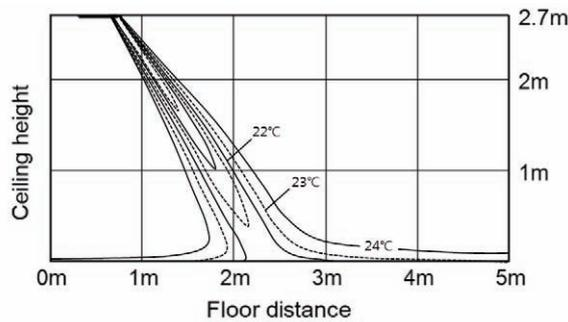

Heating Air Velocity distribution Discharge angle : 60°

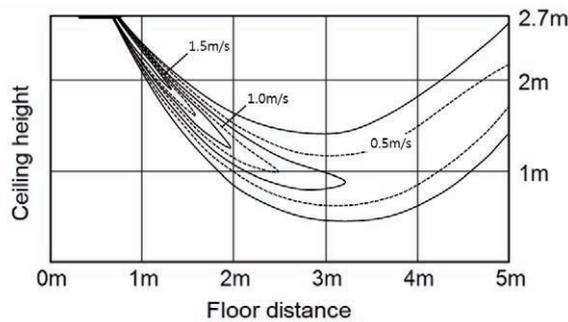

Heating temperature distribution Discharge angle : 60°

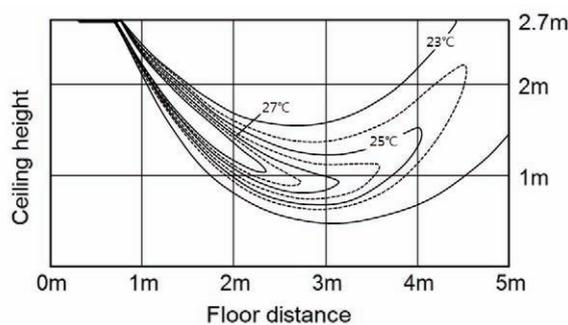

9. Temperature and Air Flow Distribution

Wind-Free 1Way Cassette

- AM022NN1DEH/××

Cooling Air Velocity distribution Discharge angle : 60°

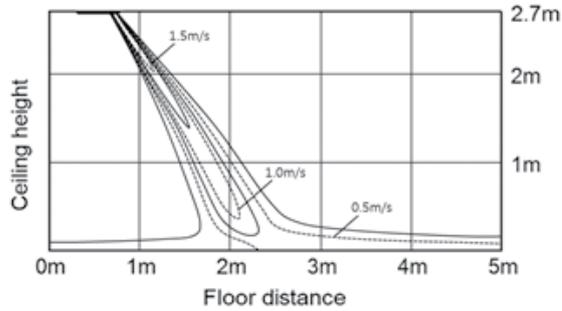

Cooling temperature distribution Discharge angle : 60°

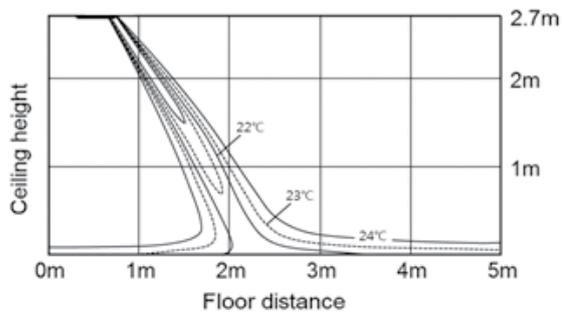

Heating Air Velocity distribution Discharge angle : 60°

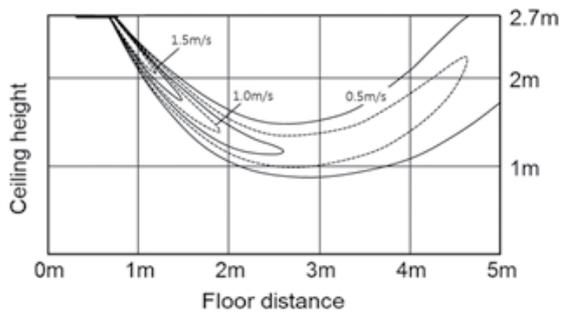

Heating temperature distribution Discharge angle : 60°

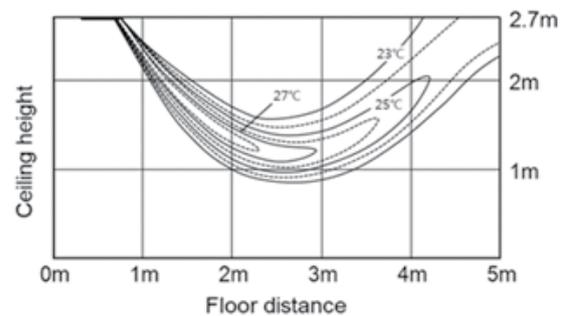

9. Temperature and Air Flow Distribution

Wind-Free 1Way Cassette

- AM028NN1DEH/××

Cooling Air Velocity distribution Discharge angle : 60°

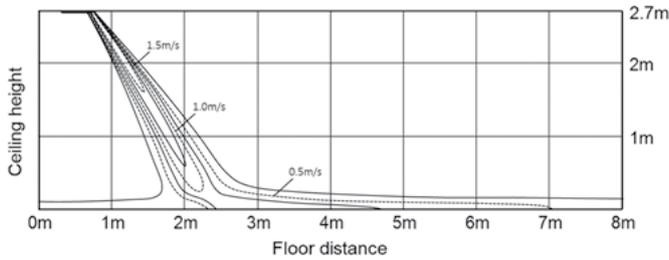

Cooling temperature distribution Discharge angle : 60°

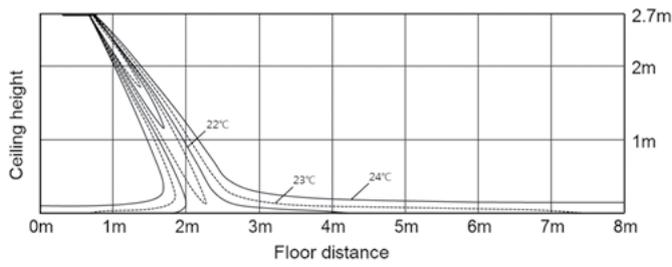

Heating Air Velocity distribution Discharge angle : 60°

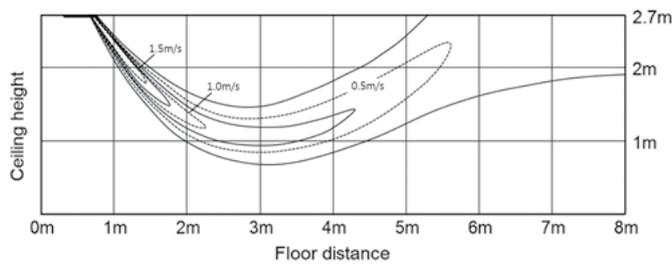

Heating temperature distribution Discharge angle : 60°

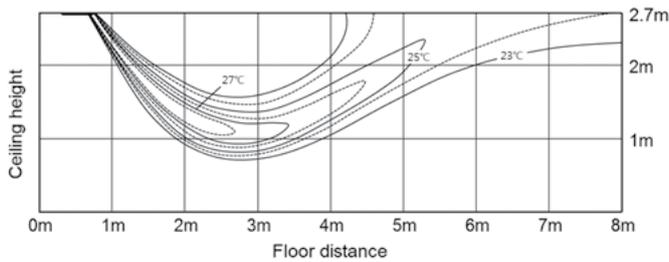

9. Temperature and Air Flow Distribution

Wind-Free 1Way Cassette

- AM036NN1DEH/XX

Cooling Air Velocity distribution Discharge angle : 60°

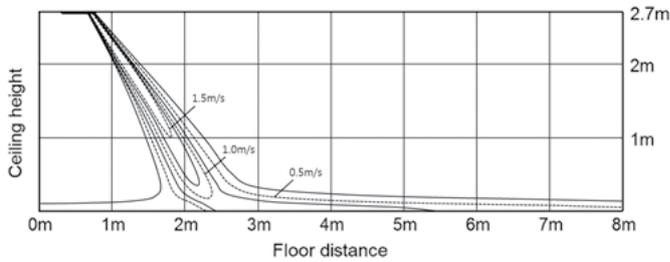

Cooling temperature distribution Discharge angle : 60°

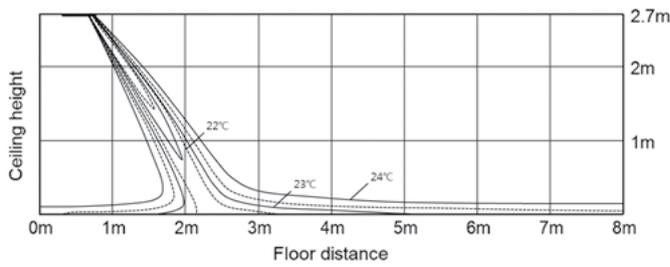

Heating Air Velocity distribution Discharge angle : 60°

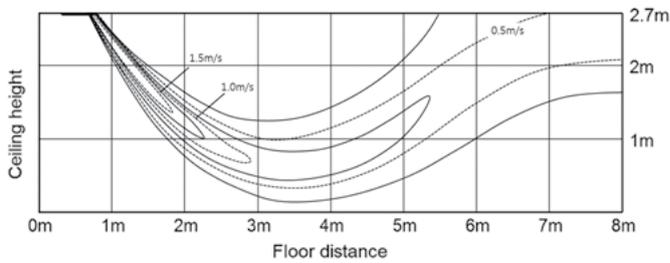

Heating temperature distribution Discharge angle : 60°

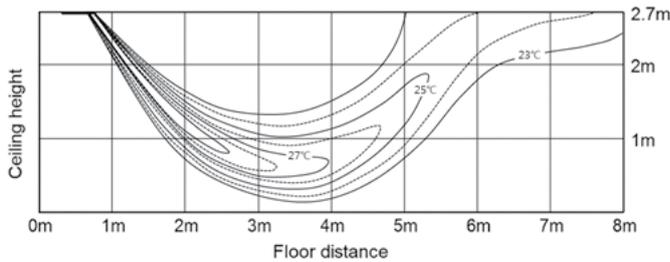

9. Temperature and Air Flow Distribution

Wind-Free 1Way Cassette

- AM056NN1DEH/××

Cooling Air Velocity distribution

Discharge angle : 60°

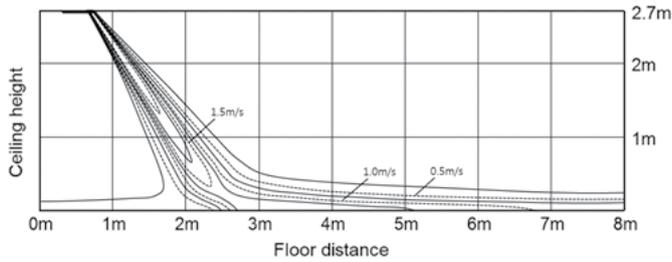

Cooling temperature distribution

Discharge angle : 60°

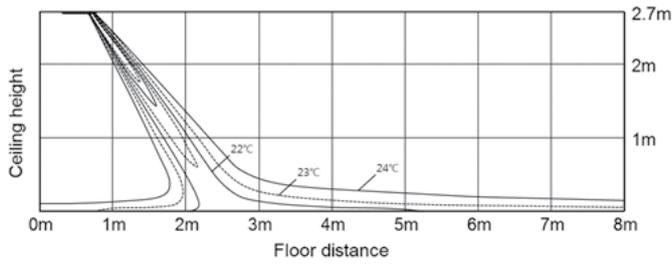

Heating Air Velocity distribution

Discharge angle : 60°

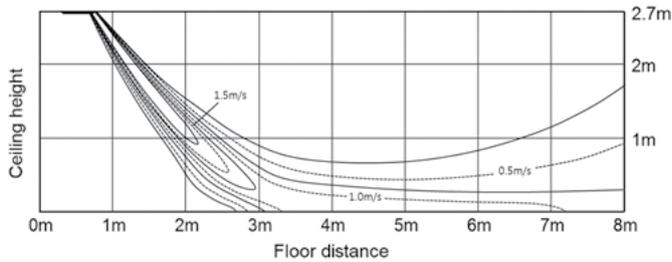

Heating temperature distribution

Discharge angle : 60°

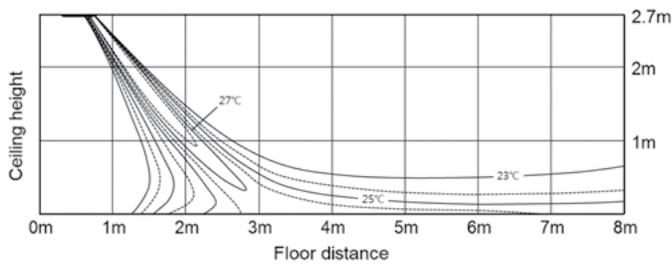

9. Temperature and Air Flow Distribution

Wind-Free 1Way Cassette

- AM071NN1DEH/XX

Cooling Air Velocity distribution Discharge angle : 60°

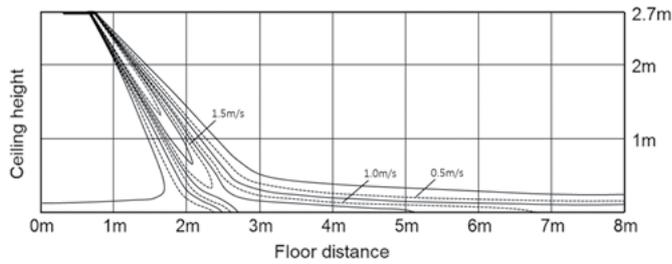

Cooling temperature distribution Discharge angle : 60°

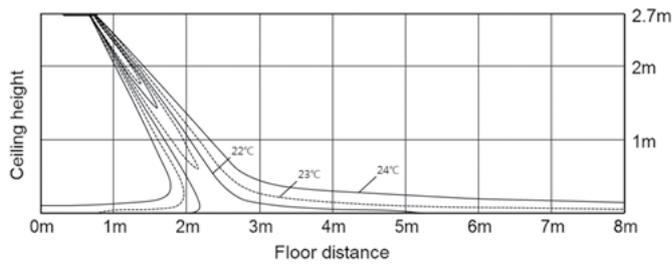

Heating Air Velocity distribution Discharge angle : 60°

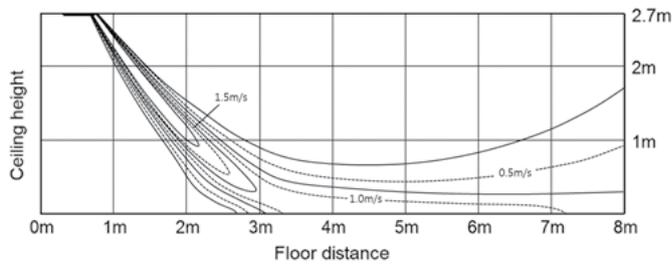

Heating temperature distribution Discharge angle : 60°

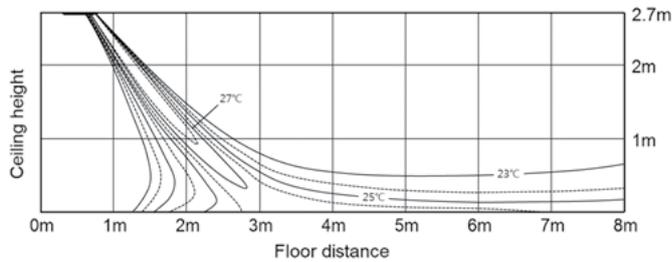

10. Piping Diagram

Wind-Free 1Way Cassette

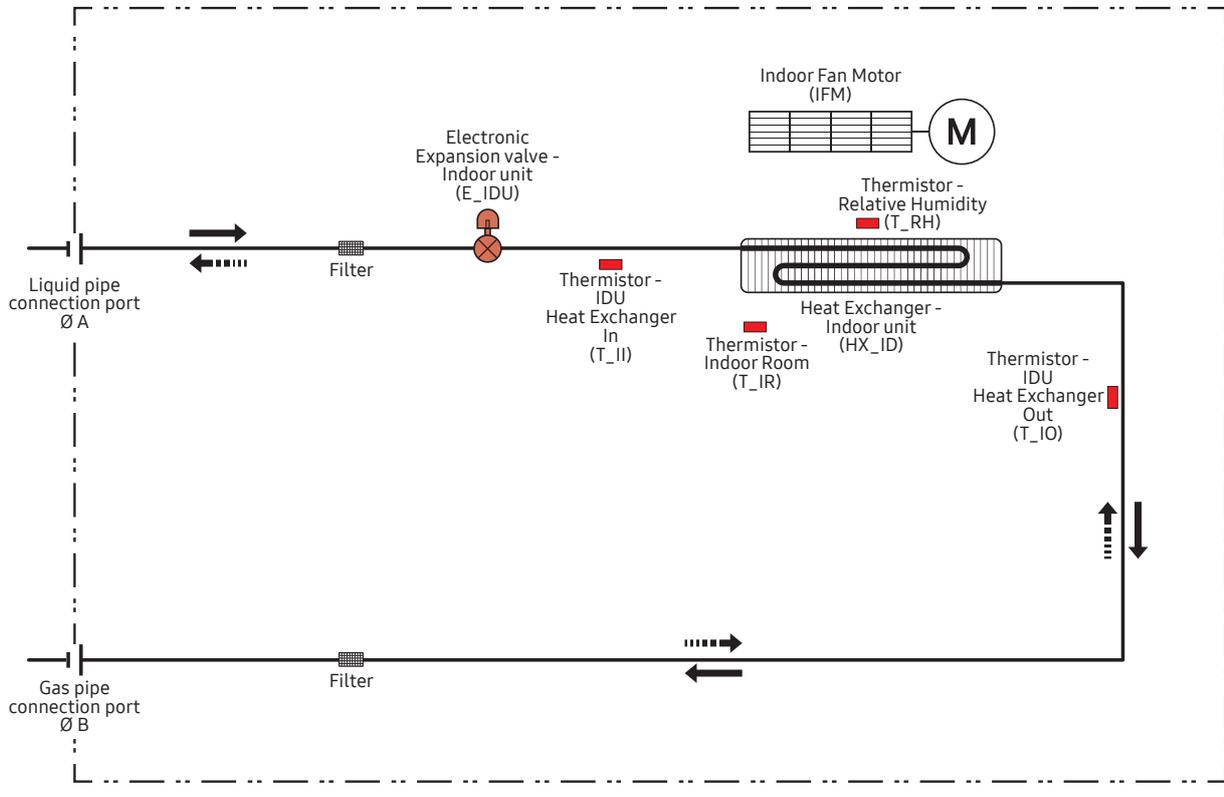

Refrigerant flow	
Cooling	Heating

Unit : mm [Inches]

Model	A	B
AM017NN1PEH/××	6.35(1/4)	12.70(1/2)
AM022NN1PEH/××	6.35(1/4)	12.70(1/2)
AM022NN1DEH/××	6.35(1/4)	12.70(1/2)
AM028NN1DEH/××	6.35(1/4)	12.70(1/2)
AM036NN1DEH/××	6.35(1/4)	12.70(1/2)
AM056NN1DEH/××	6.35(1/4)	12.70(1/2)
AM071NN1DEH/××	9.52(3/8)	15.88(5/8)

11. Installation

Wind-Free 1Way Cassette

Step1 Installing the indoor unit

When deciding on the location of the air conditioner the following restrictions must be taken into account.

- 1 Place the pattern sheet on the ceiling at the spot where you want to install the indoor unit.

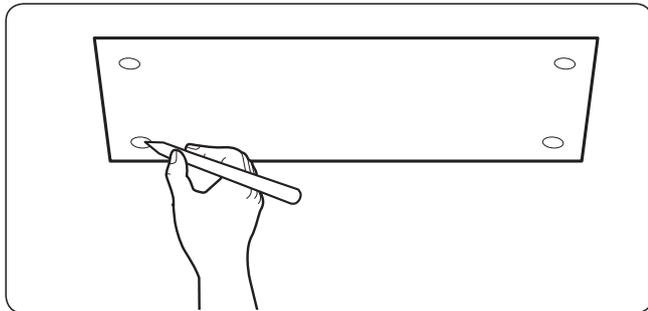

NOTE

- Since the diagram is made of paper, it may shrink or stretch slightly due to temperature or humidity. For this reason, before drilling the holes, be sure to maintain the correct dimensions between the markings.
- 2 Insert bolt anchors, use existing ceiling supports or construct a suitable support as shown in figure.

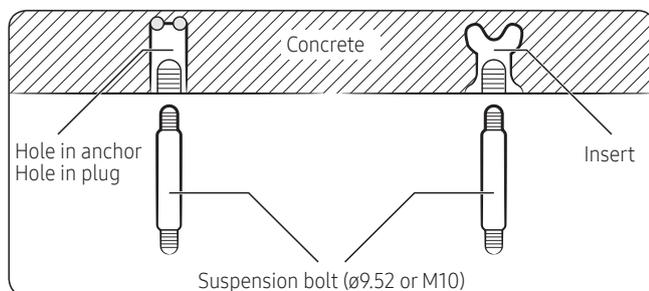

- 3 Install the suspension bolts, depending on the ceiling type.

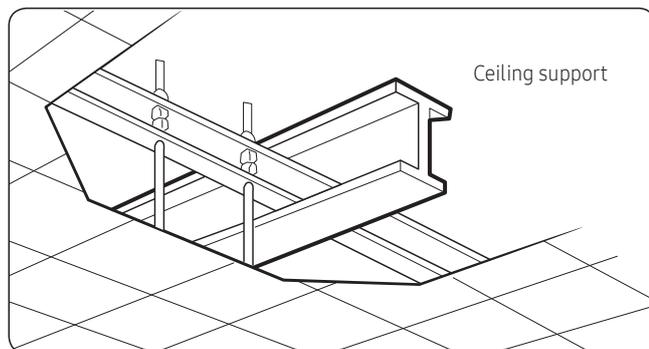

CAUTION

- Make sure that the ceiling is strong enough to support the weight of the indoor unit. Before hanging the unit, test the strength of each attached suspension bolt.
 - If the length of the suspension bolt is more than 1.5 m, you are required to prevent vibration.
 - If this is not possible, create an opening on the false ceiling in order to be able to use it to perform the required operations on the indoor unit.
- 4 Screw eight nuts and washers to the suspension bolts, making space for hanging the indoor unit.

CAUTION

- You must install all of the suspension rods.
 - It is important to leave sufficient space in the false ceiling to allow access for maintenance or repairs to the drainage pipe connection, the refrigerant pipe connection, or to remove the unit if necessary.
- 5 Hang the indoor unit to the suspension bolts between two nuts. Screw the nuts to suspend the unit.

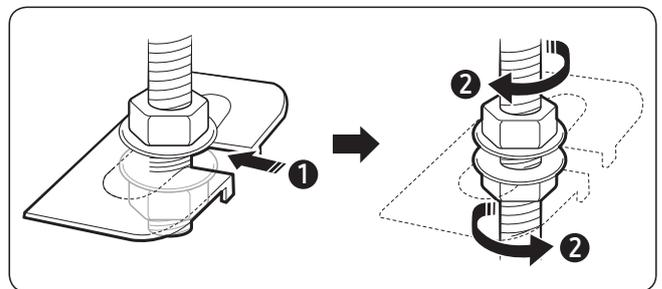

- 6 Check the level of the indoor unit by using a level.
 - A tilt of the indoor unit may cause malfunction of a built-in float switch and water leaks.

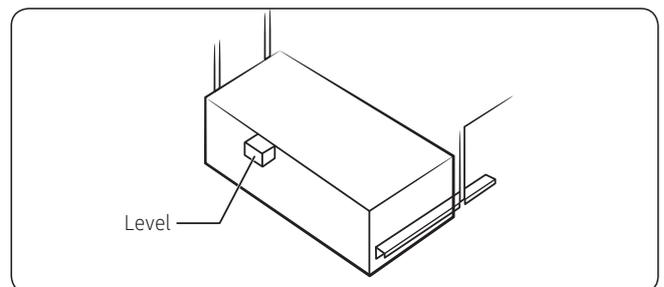

11. Installation

Wind-Free 1Way Cassette

- 7 Adjust the unit to the appropriate position, taking into account the installation area for the front panel.
- Place the pattern sheet on the indoor unit.
 - Adjust the space between the ceiling and the indoor unit by using a dimension gauge.
 - Fix the indoor unit securely after adjusting the level of the unit by using a leveller.
 - Remove the pattern sheet and install the front panel.

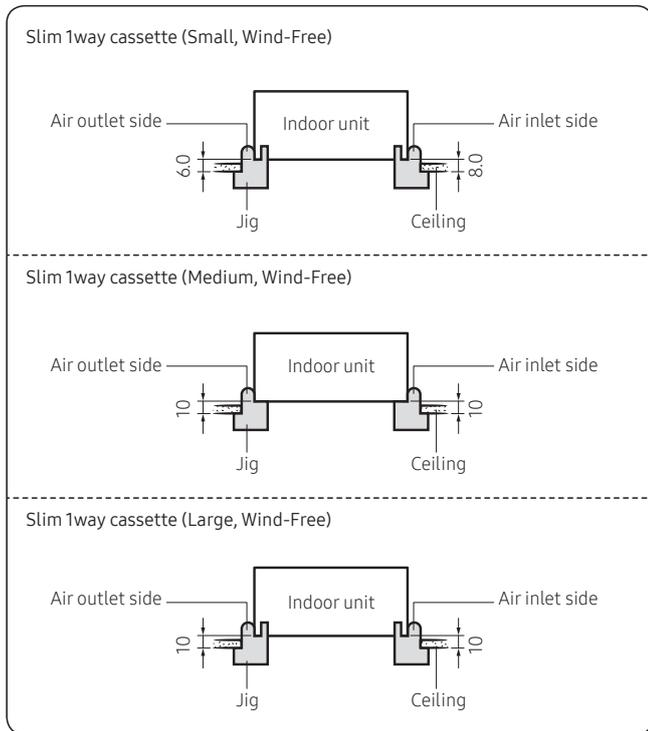

Step 2 Performing the gas leak test

To identify potential gas leaks on the indoor unit, inspect the connection area of each refrigerant pipe using a leak detector for R-410A.

Before recreating the vacuum and recirculating the refrigerant gas, pressurize the whole system with nitrogen (using a cylinder with a pressure reducer) at a pressure above 4.1 MPa in order to immediately detect leaks on the refrigerant fittings.

Made vacuum for 15 minutes and pressurizing system with nitrogen.

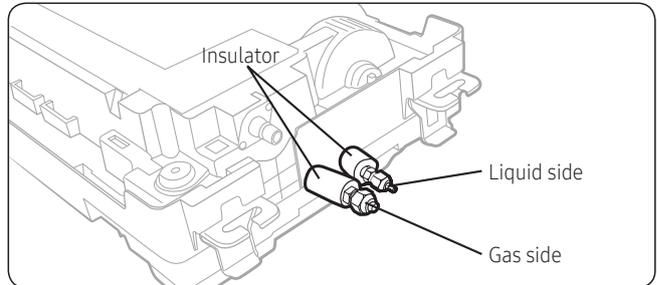

Step 3 Insulating the refrigerant pipes

Once you have checked that there are no leaks in the system, you can insulate the piping and hose.

- 1 To avoid condensation problems, place Acrylonitrile Butadien Rubber separately around each refrigerant pipe.

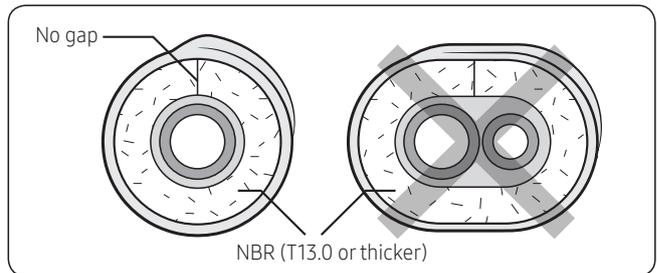

NOTE

- Always make the seam of pipes face upwards.
- 2 Wind insulating tape around the pipes and drain hose avoiding compressing the insulation too much.
 - 3 Finish wrapping insulating tape around the rest of the pipes leading to the outdoor unit.
 - 4 The pipes and electrical cables connecting the indoor unit with the outdoor unit must be fixed to the wall with suitable ducts.

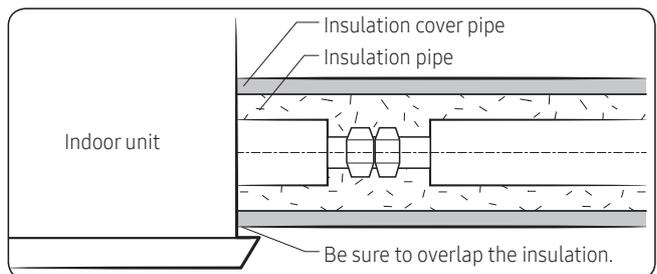

11. Installation

Wind-Free 1Way Cassette

CAUTION

- Must fit tightly against body without any gap.
- Install the insulation not to get wider and use the adhesives on the connection part of it to prevent moisture from entering.
- Wind the refrigerant pipe with insulation tape if it is exposed to outside sunlight.
- Install the refrigerant pipe respecting that the insulation does not get thinner on the bent part or hanger of pipe.
- Add the additional insulation if the insulation plate gets thinner.

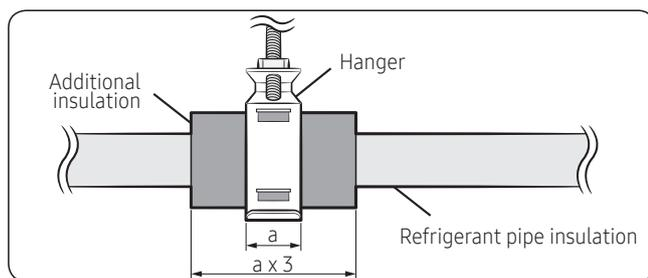

- Must fit tightly against body without any gap.
 - All refrigerant connection must be accessible, in order to permit either unit maintenance or removal.
- 5 Select the insulation of the refrigerant pipe.
- Insulate the gas side and liquid side pipe, noting the insulation thickness that must differ according to the pipe size.
 - Standard: Less than an indoor temperature of 30°C, with humidity at 85%. If installing in a high humidity environment, use one grade thicker insulator by referring to the table below. If installing in an unfavourable environment, use thicker one.
 - The heat-resistance temperature of the insulator must be more than 120°C.

Pipe	Pipe size	Insulation Type (Heating/Cooling)		Remarks
		Standard [30°C, 85%]	High humidity [30°C, over 85%]	
		EPDM, NBR		
Liquid pipe	Ø6.35 to Ø9.52	9t	←	Internal temperature is higher than 120°C
	Ø12.7 to Ø50.80	13t	←	
Gas pipe	Ø6.35	13t	19t	
	Ø9.52 to Ø25.40	19t	25t	
	Ø28.58 to Ø44.45		32t	
	Ø50.80	25t	38t	

11. Installation

Wind-Free 1Way Cassette

- When installing insulation in the places and conditions below, use the same insulation that is used for high humidity conditions.

<Geological condition>
High humidity locations such as shorelines, hot springs, lake or riversides, and ridges (when part of the building is covered by earth and sand)
<Operation purpose condition>
Restaurant ceiling, sauna, swimming pool etc.
<Building construction condition>
Ceilings frequently exposed to moisture and cooling are not covered. For example, pipes installed at a corridor of a dormitory and studio or near an exit that opens and closes frequently. Places (where the pipes are installed) that are highly humid due to a lack of ventilation.

- Refrigerant pipe before EEV kit and MCU or without EEV kit and MCU
 - You can contact the gas side and liquid side pipes but the pipes should not be pressed.
 - When contacting the gas side and liquid side pipe, use 1 grade thicker insulator.
 - Refrigerant pipe after EEV kit and MCU
 - Install the gas side and liquid side pipes, leave 10mm of space.
 - When contacting the gas side and liquid side pipe, use 1 grade thicker insulator.
- 6 Push the drain hose up to insulation when connecting the drain hose to drain socket.

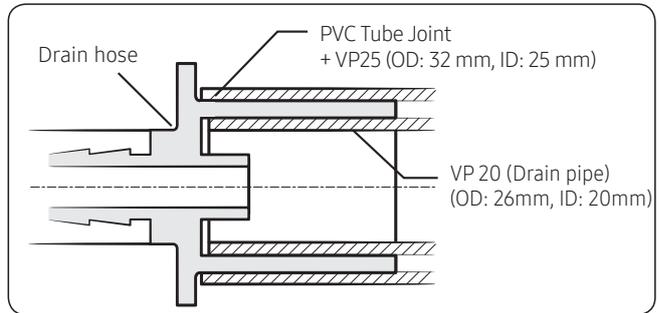
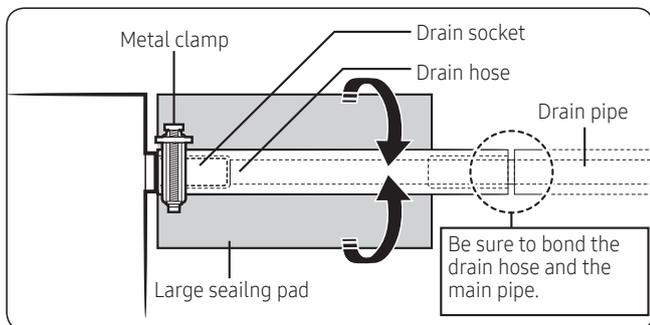

⚠ CAUTION

Check that the indoor unit is level with the ceiling by using the leveller.

- Install air ventilation to drain condensation smoothly.

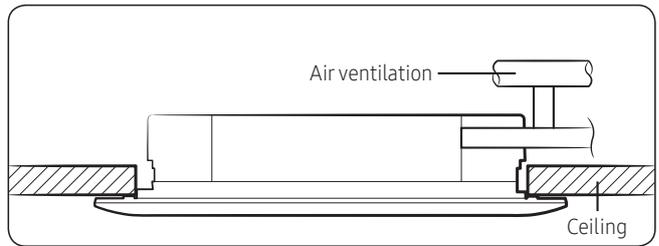

- If it is necessary to increase the height of the drain pipe, install the drain pipe straight within 300 mm from the drain hose port. If it is raised higher than 550 mm, there may be water leaks.

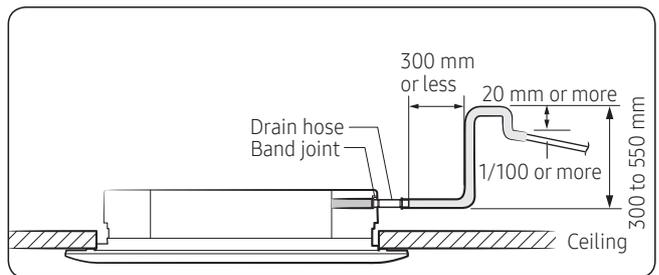

11. Installation

Wind-Free 1Way Cassette

- Do not give the hose an upward gradient beyond the connection port. This will cause water to flow backwards when the unit is stopped, resulting in water leaks.

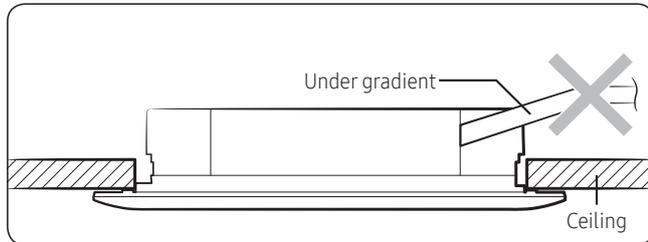

- Do not apply force to the piping on the unit side when connecting the drain hose. The hose should not be allowed to hang loose from its connection to the unit. Fasten the hose to a wall, frame or other support as close to the unit as possible.

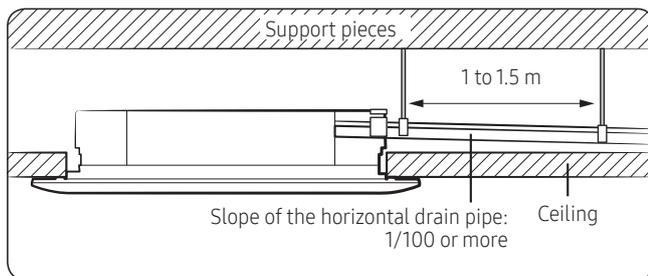

- Install horizontally.

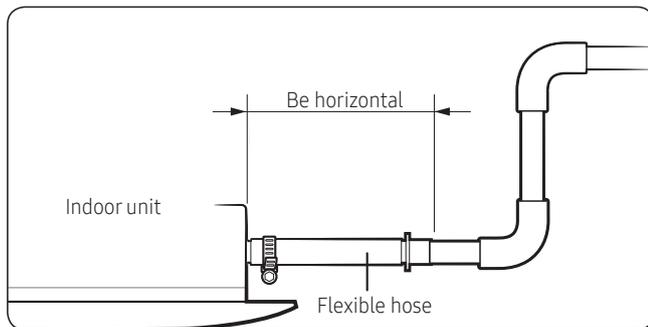

- Max. allowable aixe gap

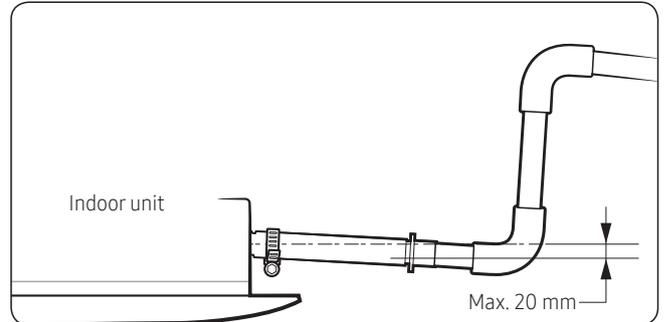

- Max. allowable bending angle

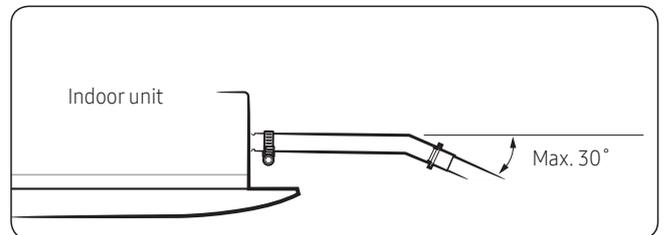

NOTE

- If a concentrated drain pipe is installed, refer to the figure below.

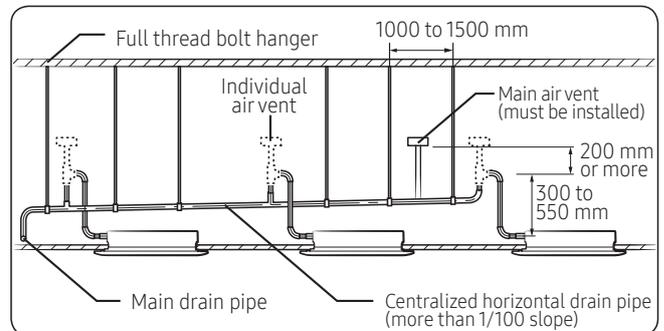

- If 3 or more units are installed, install the main air vent at the front of the farthest indoor unit from the main drain pipe.
- To prevent water from flowing back to indoor units, install an individual air vent at the top of each indoor unit.
 - The air vents should be T or 7 shaped to prevent dust or foreign substances from entering.
 - You may not need to install air vent if the horizontal drain pipe is in proper slope.

11. Installation

Wind-Free 1Way Cassette

Step 4 Connecting the power and communication cables

Power and communication cable connection

- Before wiring work, you must turn off all power source.
- Connect the power and communication cable among the units within maximum length to set the voltage drop under 10%.
- The auxiliary circuit breaker (ELCB, MCCB, ELB) should be considered more capacity if many indoor units are connected from one breaker.
- Connect F3, F4(for communication) to the communication cable of the wired remote control.
- Tighten the electric wires with a proper tool within the torque limit to connect and fix them firmly, and then organize the wires to prevent outside pressure being exerted on the covers and other parts. Failure to do so may result in overheating, electric shock, and fire.
- To protect the product from water and possible shock, you should keep the power and the communication cables of the indoor and outdoor units in the iron pipe.
- Connect the power cable to the auxiliary circuit breaker (ELCB, MCCB, ELB).
- Keep distances of 50mm or more between power cable and communication cables.
- Power supply cords of parts of appliances for outdoor use shall not be lighter than polychloroprene sheathed flexible cord. (Code designation IEC:60245 IEC 57 / CENELEC: H05RN-F or IEC:60245 IEC 66 / CENELEC: H07RN-F)
- Screws on terminal block must not be unscrewed with the torque less than 12 kgf•cm.
- When installing the indoor unit in a computer room, use the double shielded (tape aluminum / polyester braid + copper) cable of FROHH2R type.

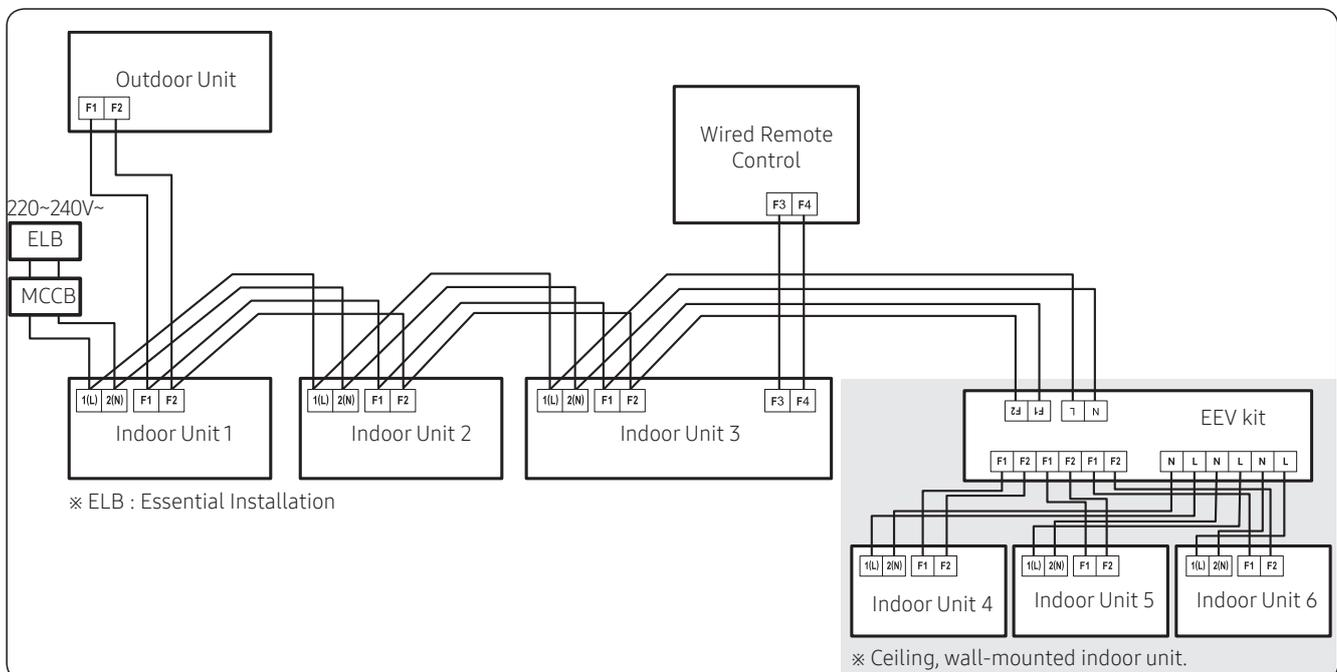

11. Installation

Wind-Free 1Way Cassette

Selecting the crimping terminal lug

- 1 Select the crimping terminal lug based on the nominal dimension of the power cable.
- 2 Cover the connection part of the power cable and crimping terminal lug to insulate it.

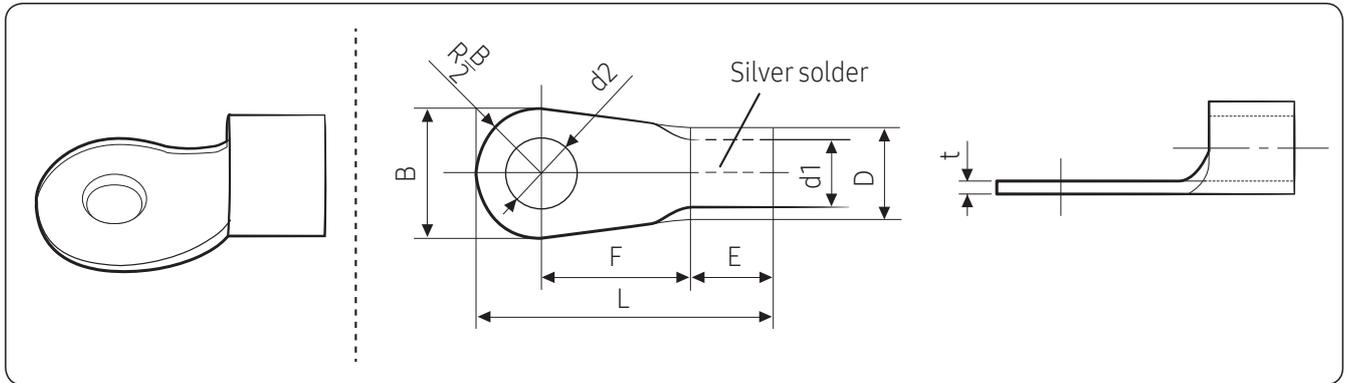

Nominal dimensions for cable (mm ²)	Nominal dimensions for screw (mm)	B		D		d1		E	F	L	d2		t
		Standard dimension (mm)	Allowance (mm)	Standard dimension (mm)	Allowance (mm)	Standard dimension (mm)	Allowance (mm)	Min.	Min.	Max.	Standard dimension (mm)	Allowance (mm)	Min.
1.5	4	6.6	± 0.2	3.4	+0.3 -0.2	1.7	± 0.2	4.1	6	16	4.3	+0.2 0	0.7
	4	8											
2.5	4	6.6	± 0.2	4.2	+0.3 -0.2	2.3	± 0.2	6	6	17.5	4.3	+0.2 0	0.8
	4	8.5											
4	4	9.5	± 0.2	5.6	+0.3 -0.2	3.4	± 0.2	6	5	20	4.3	+0.2 0	0.9

11. Installation

Wind-Free 1Way Cassette

Specifications of the terminal blocks

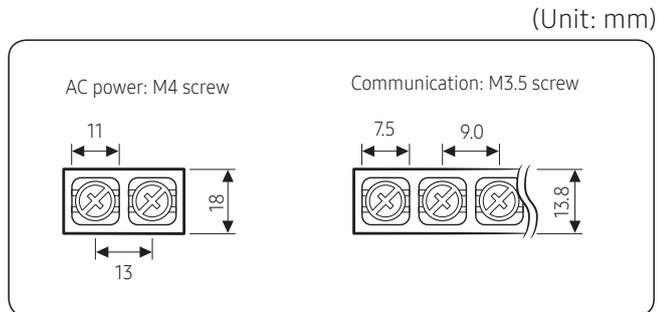

Power supply (single phase)	MCCB	ELB
Min : 198V Max : 242V	XA	XA, 30 mA 0.1 s
Power cable	Earth cable	Communication cable
2.5 mm or more	2.5 mm ²	0.75 to 1.5 mm ²

Decide the power cable specification and maximum length by formula 2.

- Decide the capacity of ELB and MCCB by below formula.

$$\text{The capacity of ELB, MCCB } X[A] = 1.25 \times 1.1 \times \Sigma A_i$$

NOTE

- X : The capacity of ELB, MCCB
- ΣA_i : Sum of rating currents of each indoor unit.

Rated currents

Model	Rating current(A)
AM017NN1PEH*	0.14
AM022NN1PEH*	0.15
AM022NN1DEH*	0.20
AM028NN1DEH*	0.23
AM036NN1DEH*	0.25
AM056NN1DEH*	0.28
AM071NN1DEH*	0.40

- Decide the power cable specification and maximum length within 10% voltage drop among indoor units.

$$\sum_{k=1}^n \left(\frac{\text{Coef} \times 35.6 \times L_k}{1000 \times A_k} \times i_k \right) < 10\% \text{ of input voltage}[V]$$

NOTE

- Coef: 1.55
- L_k: Distance among each indoor unit[m],
- A_k: Power cable specification[mm²]
- i_k: Running current of each unit[A]

12. Accessory

Wind-Free 1Way Cassette

Controller

Classification	Product	Model	Image	Remark	Using
Individual Control System	Wireless Remote Controller	AR-EH03E			DVM, CAC
	Wired Remote Controller	MWR-WE11N			DVM, CAC
	Wired Remote Controller - Simple Type	MWR-SH00N			DVM, CAC
	Wired Remote Controller - Touch Simple Type	MWR-SH10N			DVM, CAC
	ERV Wired Remote Controller	MWR-VH12N		ERV Only	DVM, CAC
	Wired Remote Controller	MWR-WW00N		EHS Only	EHS
	Receiver KIT	MRK-A10N			DVM, CAC
	Zone Controller	MWR-ZS00N		Master controller + Damper controller	DVM, CAC
	Zone Controller	MWR-ZS10N		Slave controller	DVM, CAC
	Zone Controller	MRW-TS		External room sensor	DVM, CAC

12. Accessory

Wind-Free 1Way Cassette

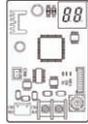
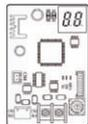
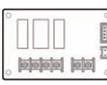
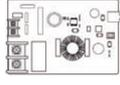
Classification	Product	Model	Image	Remark	Using
Centralized Control System	Onoff Controller	MCM-A202DN			DVM, CAC
	Touch Centralized Controller	MCM-A300N			DVM, CAC
	WIFI KIT	MIM-H03N			DVM, CAC
	Interface Module	MIM-N01			DVM, CAC
	ERV Interface Module	MIM-N10			DVM, CAC
Integrated management System	DMS2.5	MIM-D01AN			DVM, CAC
	S-NET3	MST-P3P			DVM, CAC
Gate Way	BACnet Gateway	MIM-B17BN			DVM, CAC
	Lonworks Gateway	MIM-B18BN			DVM, CAC
	External Contact Interface Module	MIM-B14			DVM, CAC
	MTFC (Multi Tenant Function Controller)	MCM-C210N			DVM
	PIM (Pulse Interface Module)	MIM-B16N			DVM, CAC

12. Accessory

Wind-Free 1Way Cassette

Classification	Product	Model	Image	Remark	Using
Installation /Test run Solution	S-Checker	MIM-C10N			DVM, CAC
	S-Converter	MIM-C02N			DVM, CAC
Others	External Room Sensor	MRW-TA			DVM, CAC
	Operation Mode Selection Switch	MCM-C200			DVM

NOTE

- In case you want more information about the accessories, please refer to the control and accessories TDB on pvi.Samsung.com site.

12. Accessory

Wind-Free 1Way Cassette

Piping

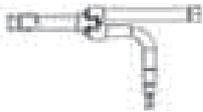
Product	Image	Model	Remark
Y-Joint		MXJ-YA1509M	15.0 kW and below
		MXJ-YA2512M	Over 15.0 kW ~ 40.0 kW and below
		MXJ-YA2812M	Over 40.0 kW ~ 45.0 kW and below
		MXJ-YA2815M	Over 45.0 kW ~ 70.3 kW and below
		MXJ-YA3419M	Over 70.3 kW ~ 98.4 kW and below
		MXJ-YA4119M	Over 98.4 kW ~ 135.2 kW and below
		MXJ-YA4422M	Over 135.2 kW
Y-Joint (Only H/R)		MXJ-YA1500M	22.4 kW and below
		MXJ-YA2500M	Over 22.4 kW ~ 70.3 kW and below
		MXJ-YA3100M	Over 70.3 kW ~ 135.2 kW and below
		MXJ-YA3800M	Over 135.2 kW
Y-Joint Outdoor Unit		MXJ-TA3419M	135.2 kW and below
		MXJ-TA4122M	140.2 kW and Over
Y-Joint (Only H/R) Outdoor Unit		MXJ-TA3100M	135.2 kW and below
		MXJ-TA3800M	140.2 kW and Over
Distribution Header		MXJ-HA2512M	45.0 kW and below (for 4 rooms)
		MXJ-HA3115M	70.3 kW and below (for 8 rooms)
		MXJ-HA3819M	Over 70.3 kW ~ 135.2 kW and below (for 8 rooms)
MCU		MCU-S6NEE1N	~56 kW, ~6 indoor units
		MCU-S4NEE1N	~56 kW, ~4 indoor units
		MCU-S4NEE2N	~56 kW, ~6 indoor units
		MCU-S2NETK1N	~28 kW, ~2 indoor units
EEV KIT		MEV-E24SA	1 Indoor
		MEV-E32SA	
		MXD-E24K132A	2 Indoor
		MXD-E24K200A	
		MXD-E32K200A	
		MXD-E24K232A	3 Indoor
		MXD-E24K300A	
		MXD-E32K224A	
		MXD-E32K300A	
PDM KIT		MXD-A38K2A	8~12 HP
		MXD-A12K2A	14~16 HP
		MXD-A58K2A	18~26 HP

NOTE

- In case you want more information about the accessories, please refer to the control and accessories TDB on pvi.Samsung.com site.

12. Accessory

Wind-Free 1Way Cassette

Indoor

Product	Image	Model	Remark
Panel		PC1NUSMAN	1Way CST (JSF-1)
		PC1NUPMAN	1Way CST (JSF-1) (Z-sliding)
		PC1MWSKAN	1Way CST (JSF-0)
		PC1NWSMAN	1Way CST (JSF-1)
		PC1BWSMAN	1Way CST (JSF-2)
		PC1MWFMAN	Wind-free 1Way CST (Small)
		PC1NWFMAN	Wind-free 1Way CST (Middle)
		PC1BWFMAN	Wind-free 1Way CST (Large)
S-Plasma Ion KIT		MSD-CAN1	[Option] 4Way, 4Way (600x600), 360, Big Ceiling [Include] Console
		MSD-EAN1	[Option] Duct S, Big Duct, ERV, ERV Plus
Motion detect Sensor		MCR-SMA	4Way Cassette S (600x600)
External room sensor		MRW-TA	Cassette, Wall-mount, Ceiling, Duct, Console

NOTE

- In case you want more information about the accessories, please refer to the control and accessories TDB on pvi.Samsung.com site.

2018. 09
Ver.1.21

Samsung Electronics Co., LTD.

B2B PM / SE

Head Office (Suwon Korea) 129, Samsung-Ro, Yeongtong-Gu, Suwon City, Gyeonggi-Do, Korea 16677

Website : www.samsung.com, <http://btsp.samsungsbn.com> Email : airconditioner@samsung.com

Images and data in this book may subject to change without prior notice.