

SAMSUNG

EHS

Technical

Data Book

EHS tank integrated Hydro Unit for Europe
(Split, R32, 50Hz, HP)



Model : Outdoor unit (AE***RXED*G/EU)
Hydro unit (AE***RNWS*G/EU)

History

Version	Modification	Date	Remark
Ver.1.0	Released EHS tank integrated Hydro Unit for Europe TDB (Split, R32, 50Hz, HP, 1st Version)	19. 02. 01	
Ver.1.1	Released EHS tank integrated Hydro Unit for Europe TDB (Split, R32, 50Hz, HP)	19. 05. 07	
Ver.1.2	Modified the Operation range	19.11. 04	
Ver.1.3	Modified the Hydro unit Dimensional drawing and minor specification	20.03.04	
Ver.2.0	Updated some formats (Specification, Drawing)	21.08.27	
Ver.2.1	Modified some contents	21. 11. 12	

Nomenclature

Outdoor Unit

Model Name

AE	040	R	X	E	D	E	G	/	EU
(1)	(2)	(3)	(4)	(5)	(6)	(7)	(8)		Buyer

(1) Classification

AC	CAC
AM	DVM
AJ	FJM (Free Joint Multi)
AE	EHS

(2) Capacity

X1/10 kW (3 digits)

(3) Version

R	2019
---	------

(4) Product Type

S	SET (NASA)
N	Indoor Unit (NASA)
X	Outdoor Unit (NASA)
A	SET (Non NASA)
B	Indoor Unit (Non NASA)
C	Outdoor Unit (Non NASA)

(5) Feature 1

E	Split
T	TDM
Y	MONO

(6) Feature 2

D	Deluxe
P	Premium

(7) Rating Voltage

A	115V, 60hz, 1Φ
B	220V, 60Hz, 1Φ
C	208~230V, 60Hz, 1Φ
D	200~220V, 50Hz, 1Φ
E	220~240V, 50Hz, 1Φ
F	208~230V, 60Hz, 3Φ
G	380~415V, 50Hz, 3Φ

(8) Mode

G	Heat Pump (R32)
---	-----------------

Nomenclature

Tank integrated hydro unit

Model Name

AE	200	R	N	W	S	E	G	/	EU
(1)	(2)	(3)	(4)	(5)	(6)	(7)	(8)		Buyer

(1) Classification

AC	CAC
AM	DVM
AJ	FJM (Free Joint Multi)
AE	EHS

(2) Capacity

x Liter (3 digits)

(3) Version

R	2019
---	------

(4) Product Type

S	SET (NASA)
N	Indoor Unit (NASA)
X	Outdoor Unit (NASA)
A	SET (Non NASA)
B	Indoor Unit (Non NASA)
C	Outdoor Unit (Non NASA)

(5) Product Notation

W	Tank integrated hydro unit
---	----------------------------

(6) Feature

S	Split
M	Mono

(7) Rating Voltage

A	115V, 60hz, 1Φ
B	220V, 60Hz, 1Φ
C	208~230V, 60Hz, 1Φ
D	200~220V, 50Hz, 1Φ
E	220~240V, 50Hz, 1Φ
F	208~230V, 60Hz, 3Φ
G	380~415V, 50Hz, 3Φ

(8) Mode

G	Heat Pump (R32)
---	-----------------

Features & Benefits

Tank integrated hydro unit

Eco-friendly heating – zero ozone impact

Eco-friendly Refrigerant R32

Reduce the impact on climate change with a Samsung EHS (Eco Heating System). The R32 refrigerant has an Ozone Depletion Potential (ODP) of zero and a lower Global Warming Potential (GWP) than conventional refrigerants*. It also reduces the amount of refrigerant needed and cuts CO2 emissions**.

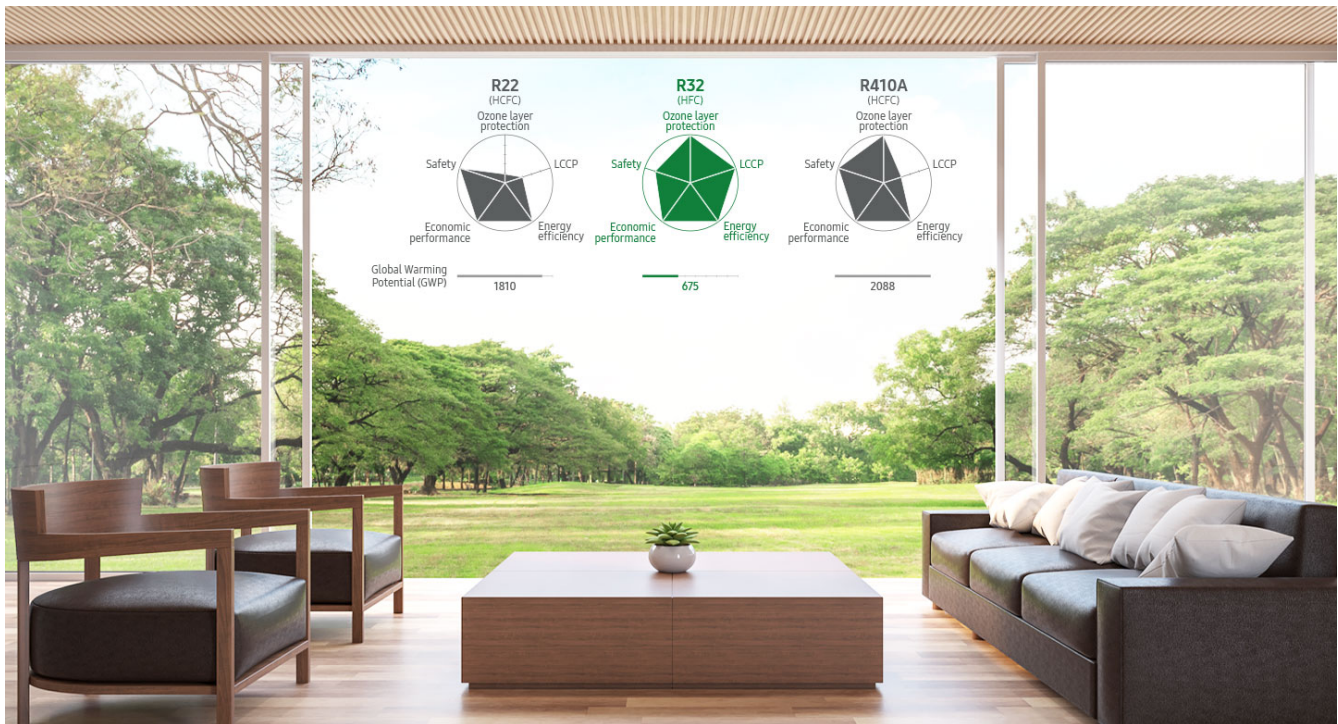

* GWP rating: R32 refrigerant = 675 vs. R410A refrigerant = 2088.

** The Samsung EHS MONO, SPLIT (R32) only requires 83% of the refrigerant used in a conventional heating system (R410A) of the same capacity. So the level of CO2 emissions of the EHS is 560 (675 x 0.83), which is 73% less than the 2088 produced by a conventional heating system.

Split

The hydraulic parts of the Samsung EHS Split are not included in the outdoor unit. Instead they are in an indoor Hydro Unit that is connected by a refrigerant pipe. So, it can be installed just like a conventional air conditioning system.

ClimateHub Split

Outdoor Unit + Tank Integrated Hydro Unit

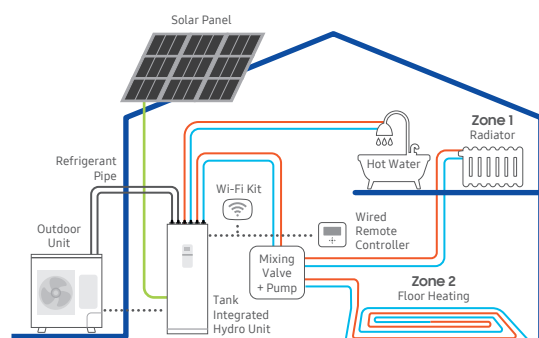

Radiator



Floor heating



Hot water



- Seasonal space heating efficiency: A+++ ~ A+ (on average)
- Leaving water temperature: Up to 55~65°C
- Capacities: 4, 6, 9, 12, 16kW
- Refrigerant: R32, R410A
- Refrigerant piping from an outdoor unit
- Power supply: 1Φ 220~240V, 3Φ 380~415V

Features & Benefits

A+++ energy efficiency saves even more

Top Class Energy Efficiency - SCOP A+++

Worry less about the cost of your heating. It has the top class SCOP A+++ energy efficiency rating across the entire range of capacities*. So it is proven to operate with a high level of efficiency, achieving a good heating performance using R32 refrigerant, which has a high PdesignH (kW)**.

* Based on testing defined in EN14825.

** PdesignH is over 100% of the rated capacity, which ensures sufficient heating performance at low temperatures. Based on a standard of -10°C (rating: standard 7°C conditions).

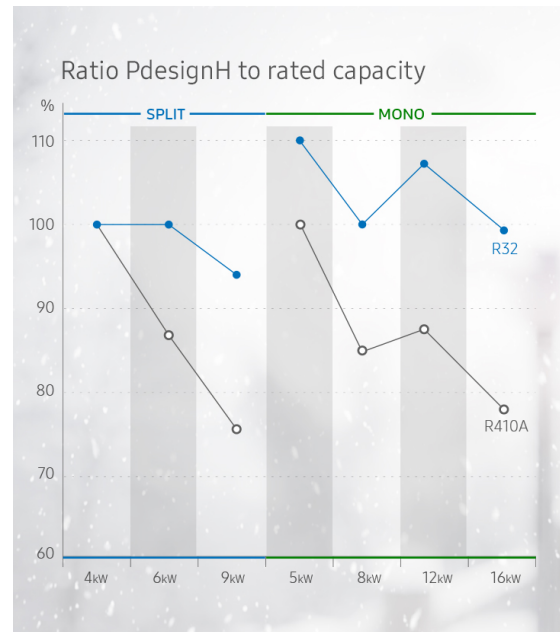

Adjustable, 4-step, low-noise operation

4-Step Quiet Mode

Makes less noise when you need to, so it doesn't disturb you or your neighbors. The 4-Step Quiet Mode enables adjustable low-noise operation to meet strict sound level requirements*. Simply select from four different steps to reduce the sound level by 3dB, 5dB, 7dB* or keep it as low as 35dB(A)*.

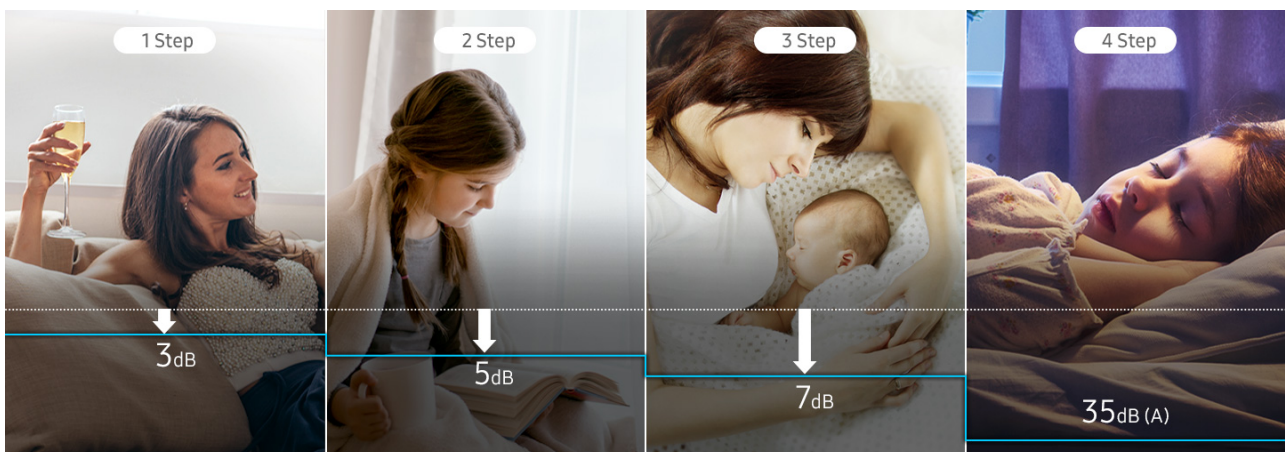

* Based on internal testing of the 6kW and 9kW SPLIT outdoor units (AE060RXEDEG, AE090RXEDEG, AE090RXEDGG). The noise level is measured 3m away from the front of the outdoor unit, in an anechoic room with an outside temperature of 7°C. Results may vary depending on the model (capacity), environmental factors and individual use.

Features & Benefits

Reduce energy usage and save money

Various Functions for Energy Saving

Save energy with advanced functions. The 2-Zone Control optimizes the temperature in two separate zones. The Photovoltaic Enabled feature checks the status of solar panels and reduces network electricity usage. And Smart Grid Ready helps you utilize economical and sustainable power options.

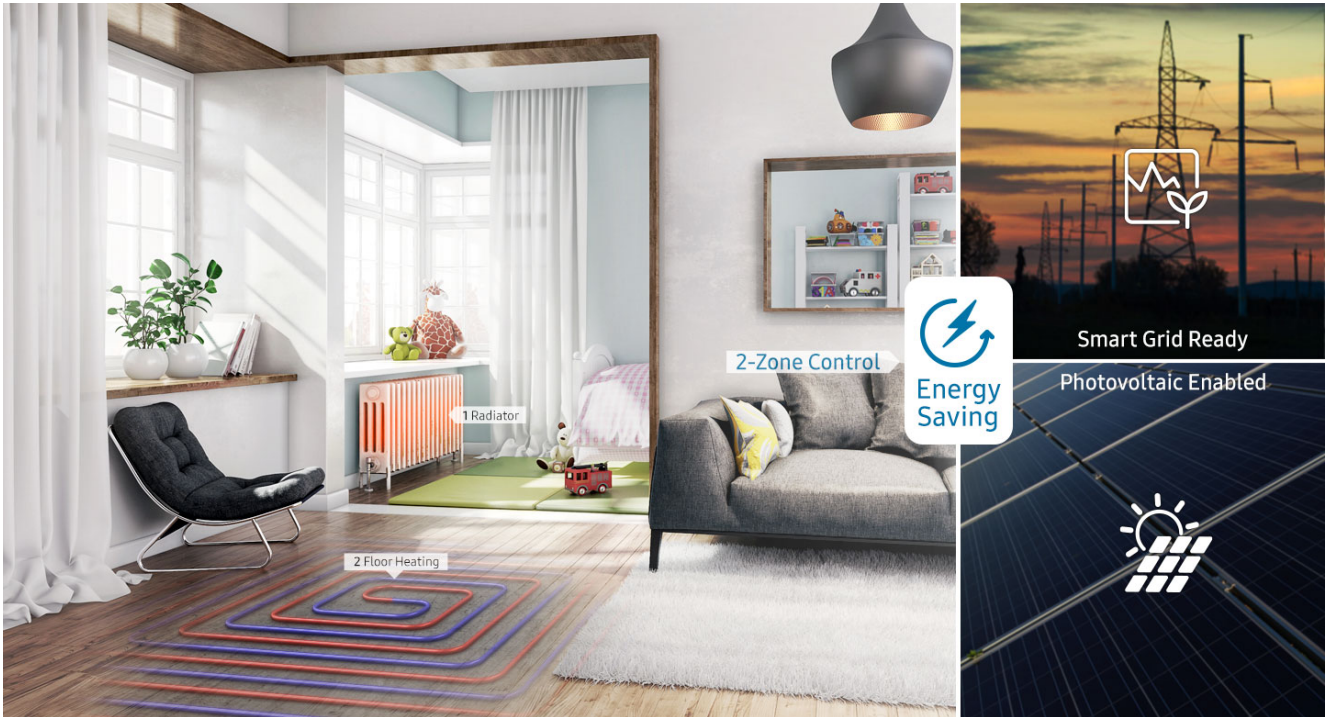

Easy remote control with a smartphone



Smart Connectivity

Control your Samsung EHS on the go. Smart Connectivity lets you turn it on/off anytime and anywhere using the SmartThings App*. And, with the touch controller, you can control the mode and settings, schedule it to start/stop, monitor energy use, adjust summer time settings and identify errors.



* Available on Android and iOS devices. A Wi-Fi connection, Samsung account and an optional Wi-Fi Kit (MIM-H04N) are required.

Contents

1. Line-up	9
1-1. Outdoor Units	9
1-2. Tank integrated hydro unit	9
2. Outdoor Units	10
2-1. Specifications	10
2-2. Electrical characteristics	14
2-3. Dimensional drawing	15
2-4. Electrical wiring diagram	17
2-5. Sound data	20
2-6. Operation range	23
2-7. Piping diagram	24
2-8. Capacity table	25
2-9. Capacity correction	28
3. Tank integrated hydro unit	29
3-1. Specifications	29
3-2. Dimensional drawing	33
3-3. Electrical wiring diagram	35
3-4. Sound data	37
3-5. Piping diagram	42
4. Installation	43
Tank integrated hydro unit	43
Outdoor Unit	50

1. Line-up

1-1. Outdoor Units

Capacity		4.4 / 6.6 kW	9.0 kW
Image			
Model	1phase	AE040RXEDEG/EU AE060RXEDEG/EU	AE090RXEDEG/EU
	3phase	-	AE090RXEDGG/EU

1-2. Tank integrated hydro unit

Type \ Capacity	200L	260L
Model	AE200RNWSEG/EU	AE260RNWSEG/EU AE260RNWSSG/EU
Hydro Unit		

2. Outdoor Units

2-1. Specifications

Model Name		Indoor Unit		AE200RNWSEG/EU	AE200RNWSEG/EU	AE200RNWSEG/EU		
		Outdoor Unit		AE040RXEDEG/EU	AE060RXEDEG/EU	AE090RXEDEG/EU		
Power Supply				Φ, #, V, Hz	1,2,220-240,50	1,2,220-240,50	1,2,220-240,50	
Mode				-	Heat Pump (A2W)	Heat Pump (A2W)	Heat Pump (A2W)	
System	Performance	Capacity	Cooling	A2W Condition #1 (A7/W35) ¹⁾	W	5,000	6,500	8,700
				Btu/h	17,100	22,200	29,700	
			Heating	A2W Condition #1 (A7/W35) ¹⁾	W	4,400	6,000	9,000
				Btu/h	15,000	20,500	30,700	
				A2W condition #2	W	4,200	5,600	8,600
				A2W condition #3		3,900	5,200	8,000
				A2/W35 ⁴⁾		4,200	5,200	7,700
	A-7/W35 ⁴⁾	4,600	5,500	7,900				
	Power	Power Input	Cooling	A2W Condition #1 (A7/W35) ¹⁾	W	1,090	1,470	2,110
				A2W Condition #1 (A7/W35) ¹⁾		846	1,220	1,870
			Heating	A2W condition #2		1,090	1,510	2,330
				A2W condition #3		1,320	1,810	2,730
				A2/W35 ⁴⁾		1,100	1,480	2,260
		Current Input	Cooling	A2W Condition #1 (A7/W35) ¹⁾	A	4.90	6.70	9.70
			Heating	A2W Condition #1 (A7/W35) ¹⁾	A	3.90	5.60	8.60
		Current	MCA		A	16.0	16.0	22.0
			MFA		A	20.0	20.0	27.5
		Efficiency	EER (Nominal Cooling) A2W condition #1				4.59	4.42
	COP (Nominal Heating) A2W condition #1				5.20	4.92	4.81	
	COP			A2W condition #2	W/W	3.85	3.71	3.69
				A2W condition #3		2.95	2.87	2.93
				A2/W35 ⁴⁾		3.82	3.51	3.41
				A-7/W35 ⁴⁾		2.97	2.75	2.72
	PdesignH (LWT 35°C)				5,000	6,000	8,500	
	SCOP (35°C)				4.58	4.58	4.45	
	SCOP Class (35°C)				A+++	A+++	A+++	
	SEER				4.40	4.73	5.09	
	Refrigerant	Piping Connections	Liquid Pipe	Φ, mm	6.35	6.35	6.35	
Φ, inch				1/4	1/4	1/4		
Gas Pipe			Φ, mm	15.88	15.88	15.88		
			Φ, inch	5/8	5/8	5/8		
Piping length (ODU IDU)		Max.[Equiv.]	m	30	30	35		
Level difference (IDU IDU)		Max.	m	20	20	20		
Chargeless Length			m	15	15	15		
Type				-	R32	R32	R32	
Factory Charging			kg	1.2	1.2	1.4		
			tCO ₂ e	0.81	0.81	0.95		
Control Method			-	EEV	EEV	EEV		
Outdoor Unit	Compressor	Type			BLDC Twin Rotary	BLDC Twin Rotary	BLDC Twin Rotary	
		Model Name			UB4TN8200FE4SS	UB4TN8200FE4SS	UB8TN8265FJWSG	
		Oil	Type		POE /650	POE /650	POE/700	
		Quantity		EA	1	1	1	
		Output		W	1623	1623	2078	
		Starting method			-	Inverter driven	Inverter driven	Inverter driven
	Heat exchanger	Length		mm	906.8	906.8	950	
		Rows	Quantity	EA	2	2	2	
		Fin pitch		mm	1.5	1.5	1.5	
		Passes	Quantity	EA	4	4	8	
		Face area		m ²	0.53	0.53	0.92	
		Stages	Quantity	EA	28	28	46	
		Tube type			-	Φ7	Φ7	
		Fin	Type		-	Corrugate	Corrugate	Wide Louver
	Treatment		-	NGS	NGS	Anti Salt		

2. Outdoor Units

2-1. Specifications

Model Name		Indoor Unit		AE200RNWSEG/EU	AE200RNWSEG/EU	AE200RNWSEG/EU	
		Outdoor Unit		AE040RXEDEG/EU	AE060RXEDEG/EU	AE090RXEDEG/EU	
Outdoor Unit	Fan	Type		-	Propeller Fan	Propeller Fan	Propeller Fan
		Discharge direction		-	Horizontal	Horizontal	Horizontal
		Air Flow Rate	Heating	m ³ /min	40	43	66
			Cooling	m ³ /min	40	43	66
	Fan motor	Quantity		EA	1	1	1
		Model		-	Brushless DC motor	Brushless DC motor	Brushless DC motor
		Output		W	68	68	125
		Drive		-	Direct drive	Direct drive	Direct drive
		Speed	Heating	rpm	740	800	780
	Cooling		rpm	740	800	780	
	Sound	Sound Pressure	Heating	dB(A)	44	47	49
			Cooling	dB(A)	46	47	49
			Night Mode	dB(A)	-	35	35
		Sound Power	Heating	dB(A)	58	60	64
	Cooling		dB(A)	61	62	63	
	Casing	Color		-	Earth brown	Earth brown	Earth brown
		Material		-	Powder coated Galvanised steel	Powder coated Galvanised steel	Powder coated Electro galvanised steel
	Packing	Material		-	EPS/BOX	EPS/BOX	EPS/BOX
		Weight		kg	3.0	3.0	8.5
	External Dimension	Net Weight		kg	46.5	46.5	73.0
Shipping Weight		kg	49.5	49.5	81.5		
Net Dimensions (WxHxD)		mm	880 x 638 x 310	880 x 638 x 310	940 x 998 x 330		
Shipping Dimensions (WxHxD)		mm	1,023 x 725 x 413	1,023 x 725 x 413	995 x 1,178 x 426		
Operating Temp. Range	Heating		°C	-25~35	-25~35	-25~35	
	Cooling		°C	10~46	10~46	10~46	
	D.Hot Water		°C	-25~43	-25~43	-25~43	

NOTE

- Specifications may be subject to change without prior notice.
 - 1)* A2W Condition #1 : (Heating) Water In/Out 30°C/35°C, Outdoor Air 7°C[DB]/6°C[WB]; (Cooling) Water In/Out 23°C/18°C, Outdoor Air 35°C[DB].
 - 2)* A2W Condition #2 : (Heating) Water In/Out 40°C/45°C, Outdoor Air 7°C[DB]/6°C[WB]; (Cooling) Water In/Out 12°C/7°C, Outdoor Air 35°C[DB].
 - 3)* A2W Condition #3 : (Heating) Water In/Out 47°C/55°C, Outdoor Air 7°C[DB]/6°C[WB].
 - 4)* A2W Condition : (A2W35) Water In/Out -/35°C, Outdoor Air 2°C[DB]/1°C[WB]; (A-7/W35) Water In/Out -/35°C, Outdoor Air -7°C[DB]/-(※ Peak Capacity)
- Select wire size based on the value of MCA
- Sound pressure level is obtained in an anechoic room.
 - Sound pressure level is a relative value, depending on the distance and acoustic environment.
 - Sound pressure level may differ depending on operation condition.
 - Sound pressure level in Night Mode is measured 3m away from front side of outdoor unit.
 - dBA = A-weighted sound pressure level
 - Reference acoustic pressure 0 dB = 20uPa
- Sound power level is an absolute value that a sound source generates.
 - dBA = A-weighted Sound power level
 - Reference power : 1pW
 - Measured according to ISO 3741
- These products contain R32 (GWP=675) which is fluorinated greenhouse gas.
- The system is operated in (-25°C ≤ Outdoor temp. < -20°C) condition, but no guarantee of capacity.
- The system is operated by only Booster Heater in special condition (35 °C < Outdoor temp. ≤ 43°C).

2. Outdoor Units

2-1. Specifications

Model Name		Indoor Unit		AE260RNWSGG/EU	AE260RNWSEG/EU	AE260RNWSEG/EU	AE260RNWSEG/EU				
		Outdoor Unit		AE090RXEDGG/EU	AE040RXEDEG/EU	AE060RXEDEG/EU	AE090RXEDEG/EU				
Power Supply				Φ, #, V, Hz	3,4,380-415,50	1,2,220-240,50	1,2,220-240,50	1,2,220-240,50			
Mode				-	Heat Pump (A2W)	Heat Pump (A2W)	Heat Pump (A2W)	Heat Pump (A2W)			
System	Performance	Capacity	Cooling	A2W Condition #1 (A7/W35) ¹⁾	W	8,700	5,000	6,500	8,700		
				Btu/h	29,700	17,100	22,200	29,700			
			Heating	A2W Condition #1 (A7/W35) ¹⁾	W	9,000	4,400	6,000	9,000		
				Btu/h	30,700	15,000	20,500	30,700			
				A2W condition #2	W	8,600	4,200	5,600	8,600		
				A2W condition #3		8,000	3,900	5,200	8,000		
				A2/W35 ⁴⁾		7,700	4,200	5,200	7,700		
				A-7/W35 ⁴⁾		7,900	4,600	5,500	7,900		
			Power	Power Input	Cooling	A2W Condition #1 (A7/W35) ¹⁾	W	2,110	1,090	1,470	2,110
						A2W Condition #1 (A7/W35) ¹⁾		1,870	846	1,220	1,870
	Heating	A2W condition #2			2,330	1,090		1,510	2,330		
		A2W condition #3			2,730	1,320		1,810	2,730		
		A2/W35 ⁴⁾			2,260	1,100		1,480	2,260		
		A-7/W35 ⁴⁾			2,900	1,550		2,000	2,900		
	Current Input	Cooling		A2W Condition #1 (A7/W35) ¹⁾	A	3.40	4.90	6.70	9.70		
		Heating		A2W Condition #1 (A7/W35) ¹⁾		3.00	3.90	5.60	8.60		
	Current	MCA		A	10.0	16.0	16.0	22.0			
		MFA		A	16.1	20.0	20.0	27.5			
	Efficiency	EER (Nominal Cooling) A2W condition #1				4.12	4.59	4.42	4.12		
		COP (Nominal Heating) A2W condition #1				4.81	5.20	4.92	4.81		
		COP		A2W condition #2	W/W	3.69	3.85	3.71	3.69		
				A2W condition #3		2.93	2.95	2.87	2.93		
				A2/W35 ⁴⁾		3.41	3.82	3.51	3.41		
				A-7/W35 ⁴⁾		2.72	2.97	2.75	2.72		
		PdesignH (LWT 35°C)				8,500	5,000	6,000	8,500		
		SCOP (35°C)				4.45	4.58	4.58	4.45		
		SCOP Class (35°C)				A+++	A+++	A+++	A+++		
		SEER				5.09	4.40	4.73	5.09		
Refrigerant	Piping Connections	Liquid Pipe	Φ, mm	6.35	6.35	6.35	6.35				
			Φ, inch	1/4	1/4	1/4	1/4				
		Gas Pipe	Φ, mm	15.88	15.88	15.88	15.88				
			Φ, inch	5/8	5/8	5/8	5/8				
	Piping length (ODU IDU)	Max.[Equiv.]	m	35	30	30	35				
	Level difference (IDU IDU)	Max.	m	20	20	20	20				
	Chargeless Length		m	15	15	15	15				
	Type		-	R32	R32	R32	R32				
	Factory Charging		kg	1.4	1.2	1.2	1.4				
			tCO _{2e}	0.95	0.81	0.81	0.95				
Control Method		-	EEV	EEV	EEV	EEV					
Outdoor Unit	Compressor	Type		-	BLDC Twin Rotary	BLDC Twin Rotary	BLDC Twin Rotary	BLDC Twin Rotary			
		Model Name		-	UB8TN8265FJWSG	UB4TN8200FE4SS	UB4TN8200FE4SS	UB8TN8265FJWSG			
		Oil	Type	-	POE/700	POE /650	POE /650	POE/700			
		Quantity		EA	1	1	1	1			
		Output		W	2078	1623	1623	2078			
		Starting method		-	Inverter driven	Inverter driven	Inverter driven	Inverter driven			
	Heat exchanger	Length		mm	950	906.8	906.8	950			
		Rows	Quantity	EA	2	2	2	2			
		Fin pitch		mm	1.5	1.5	1.5	1.5			
		Passes	Quantity	EA	8	4	4	8			
		Face area		m ²	0.92	0.53	0.53	0.92			
		Stages	Quantity	EA	46	28	28	46			
		Tube type		-	Φ7	Φ7	Φ7	Φ7			
		Fin	Type	-	Wide Louver	Corrugate	Corrugate	Wide Louver			
	Treatment	-	Anti Salt	NGS	NGS	Anti Salt					

2. Outdoor Units

2-1. Specifications

Model Name		Indoor Unit		AE260RNWSGG/EU	AE260RNWSEG/EU	AE260RNWSEG/EU	AE260RNWSEG/EU	
		Outdoor Unit		AE090RXEDGG/EU	AE040RXEDEG/EU	AE060RXEDEG/EU	AE090RXEDEG/EU	
Outdoor Unit	Fan	Type		-	Propeller Fan	Propeller Fan	Propeller Fan	Propeller Fan
		Discharge direction		-	Horizontal	Horizontal	Horizontal	Horizontal
		Air Flow Rate	Heating	m ³ /min	66	40	43	66
			Cooling	m ³ /min	66	40	43	66
	Fan motor	Quantity		EA	1	1	1	1
		Model		-	Brushless DC motor	Brushless DC motor	Brushless DC motor	Brushless DC motor
		Output		W	125	68	68	125
		Drive		-	Direct drive	Direct drive	Direct drive	Direct drive
		Speed	Heating	rpm	780	740	800	780
			Cooling	rpm	780	740	800	780
	Sound	Sound Pressure	Heating	dB(A)	49	44	47	49
			Cooling	dB(A)	49	46	47	49
			Night Mode	dB(A)	35	-	35	35
		Sound Power	Heating	dB(A)	64	58	60	64
	Cooling		dB(A)	63	61	62	63	
	Casing	Color		-	Earth brown	Earth brown	Earth brown	Earth brown
		Material		-	Powder coated Electro galvanized steel	Powder coated Galvanized steel	Powder coated Galvanized steel	Powder coated Electro galvanized steel
	Packing	Material		-	EPS/BOX	EPS/BOX	EPS/BOX	EPS/BOX
		Weight		kg	8.5	3.0	3.0	8.5
	External Dimension	Net Weight		kg	72.0	46.5	46.5	73.0
		Shipping Weight		kg	80.5	49.5	49.5	81.5
		Net Dimensions (WxHxD)		mm	940 x 998 x 330	880 x 638 x 310	880 x 638 x 310	940 x 998 x 330
		Shipping Dimensions (WxHxD)		mm	995 x 1,178 x 426	1,023 x 725 x 413	1,023 x 725 x 413	995 x 1,178 x 426
	Operating Temp. Range	Heating		°C	-25~35	-25~35	-25~35	-25~35
Cooling		°C	10~46	10~46	10~46	10~46		
D.Hot Water		°C	-25~43	-25~43	-25~43	-25~43		

NOTE

- Specifications may be subject to change without prior notice.
 - * A2W Condition #1 : (Heating) Water In/Out 30°C/35°C, Outdoor Air 7°C[DB]/6°C[WB]; (Cooling) Water In/Out 23°C/18°C, Outdoor Air 35°C[DB].
 - * A2W Condition #2 : (Heating) Water In/Out 40°C/45°C, Outdoor Air 7°C[DB]/6°C[WB]; (Cooling) Water In/Out 12°C/7°C, Outdoor Air 35°C[DB].
 - * A2W Condition #3 : (Heating) Water In/Out 47°C/55°C, Outdoor Air 7°C[DB]/6°C[WB].
 - * A2W Condition : (A2W35) Water In/Out -/35°C, Outdoor Air 2°C[DB]/1°C[WB]; (A-7/W35) Water In/Out -/35°C, Outdoor Air -7°C[DB]/-(* Peak Capacity)
- Select wire size based on the value of MCA
- Sound pressure level is obtained in an anechoic room.
 - Sound pressure level is a relative value, depending on the distance and acoustic environment.
 - Sound pressure level may differ depending on operation condition.
 - Sound pressure level in Night Mode is measured 3m away from front side of outdoor unit.
 - dBA = A-weighted sound pressure level
 - Reference acoustic pressure 0 dB = 20uPa
- Sound power level is an absolute value that a sound source generates.
 - dBA = A-weighted Sound power level
 - Reference power : 1pW
 - Measured according to ISO 3741
- These products contain R32 (GWP=675) which is fluorinated greenhouse gas.
- The system is operated in (-25°C ≤ Outdoor temp. < -20°C) condition, but no guarantee of capacity.
- The system is operated by only Booster Heater in special condition (35 °C < Outdoor temp. ≤ 43°C).

2. Outdoor Units

2-2. Electrical characteristics

Capacity [kW]	Model	Power Supply				Voltage Range [V]		Nominal Running Current [A]		Current [A]	
		Φ	#	Hz	Voltage	Min. (-10%)	Max. (+10%)	Cooling	Heating	MCA	MFA
4.4	AE040RXEDEG/EU	1	2	50	220~240	198	264	4.9	3.9	16.0	20.0
6.0	AE060RXEDEG/EU	1	2	50	220~240	198	264	6.7	5.6	16.0	20.0
9.0	AE090RXEDEG/EU	1	2	50	220~240	198	264	9.7	8.6	22.0	27.5
9.0	AE090RXEDGG/EU	3	4	50	380~415	342	456	3.4	3.0	10.0	16.1

NOTE

- MCA : Minimum circuit amperes
- MFA : Maximum fuse amperes
- Select wire size based on the value of MCA

2. Outdoor Units

2-3. Dimensional drawing

AE040/060RXEDEG/EU

Unit : mm

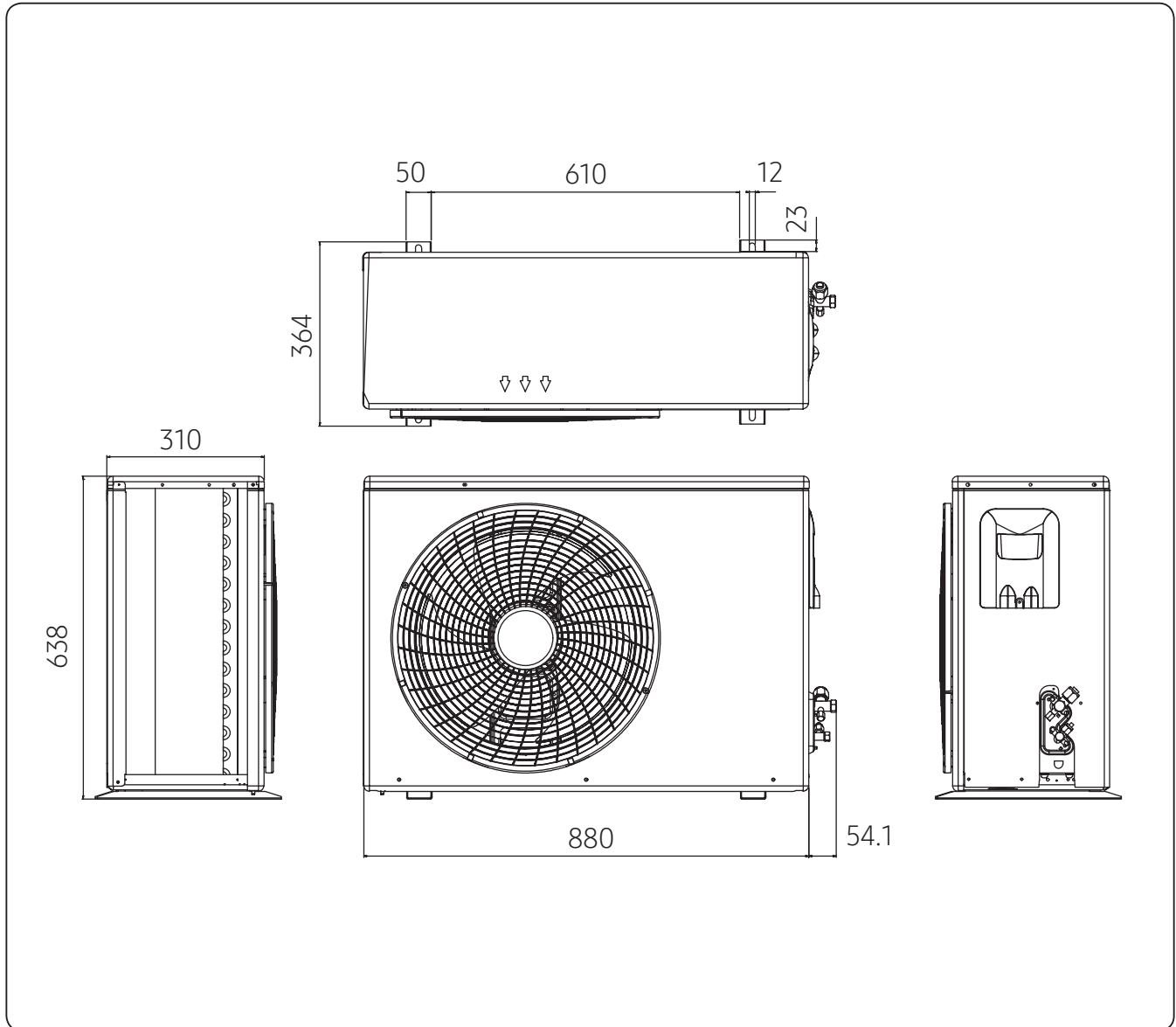

2. Outdoor Units

2-3. Dimensional drawing

AE090RXED*G/EU

Unit : mm

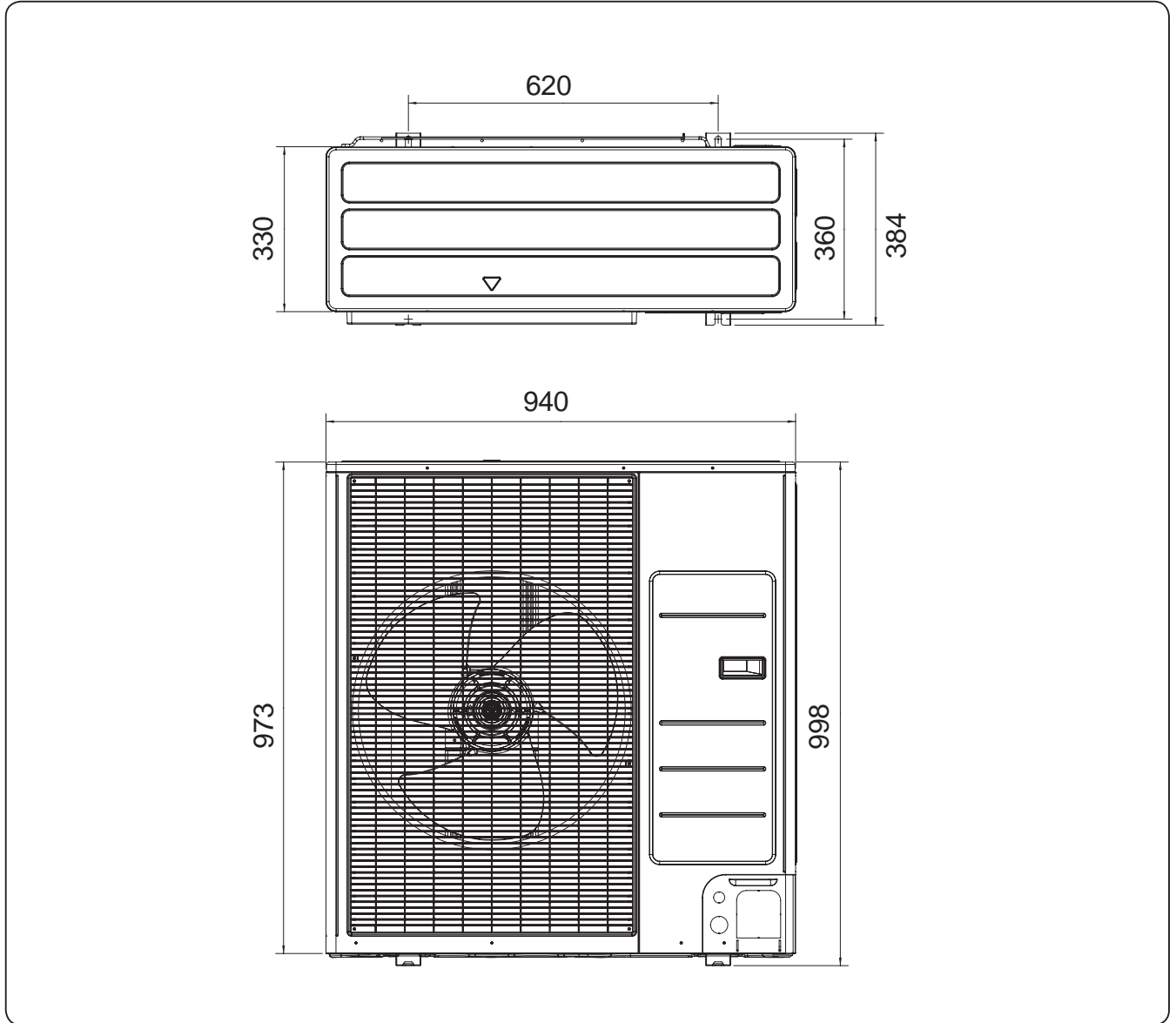

2. Outdoor Units

2-4. Electrical wiring diagram

AE040/060RXEDEC/EU

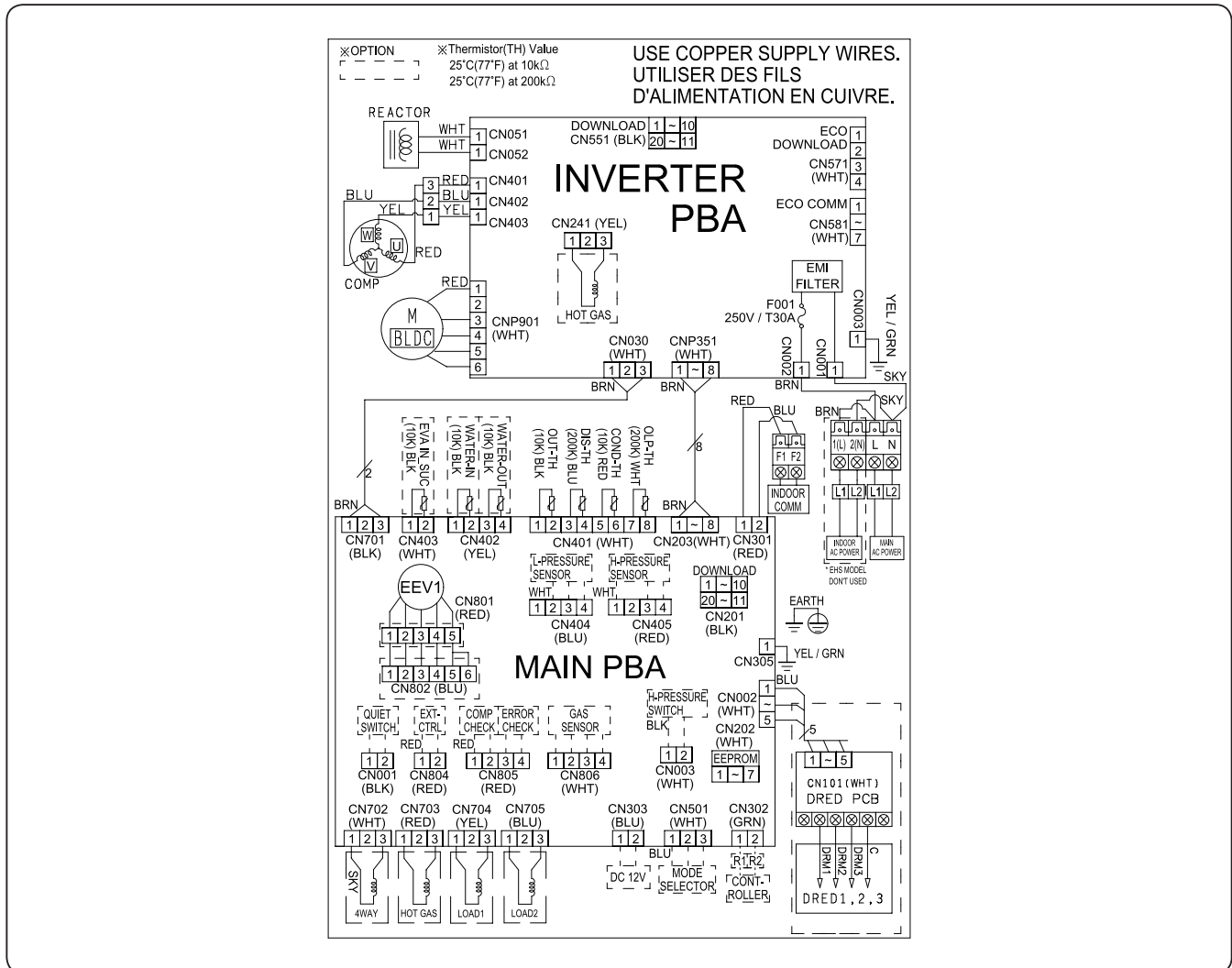

M BLDC	BLDC FAN MOTOR	COMP	COMPRESSOR
OUT-TH	Thermistor OUT(10K)	DIS-TH	Thermistor DISCHARGE(200K)
COND-TH	Thermistor COND(10K)	OLP-TH	Thermistor OLP(200K)

NOTE

1. This wiring diagram applies only to the Outdoor unit.
2. Symbols show as follow :
 blk: black, red: red, blu: blue, wht: white, yel: yellow, brn: brown, sky: skyblue, grn: green
3. For connection wiring indoor-outdoor transmission F1-F2, indoor-wired remote controller transmission F3-F4.
4. ⚡ Protective earth(SCREW)

2. Outdoor Units

2-4. Electrical wiring diagram

AE090RXEDEC/EU

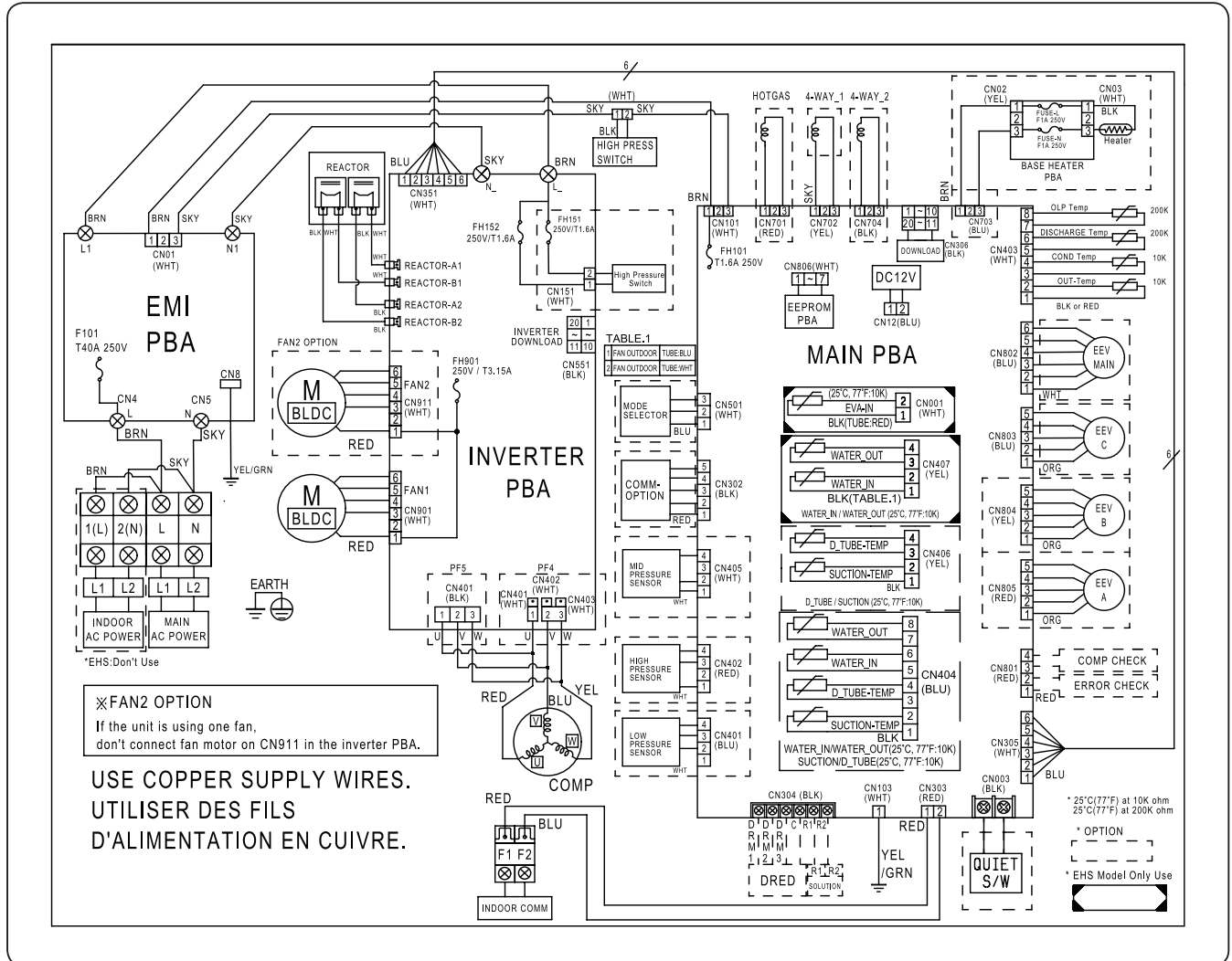

M BLDC	BLDC FAN MOTOR	COMP	COMPRESSOR
Comm	Communication	OUT-Temp	Thermistor OUT(10K)
COND-Temp	Thermistor COND(10K)	DISCHARGE-Temp	Thermistor DISCHARGE(200K)
OLP-Temp	Thermistor OLP(200K)	SUCTION-TEMP	Thermistor SUCTION(10K)

NOTE

1. This wiring diagram applies only to the Outdoor unit.
2. Symbols show as follow :
blk: black, red: red, blu: blue, wht: white, yel: yellow, brn: brown, sky: skyblue, grn: green
3. For connection wiring indoor-outdoor transmission F1-F2, indoor-wired remote controller transmission F3-F4.
4. ⊕ Protective earth(SCREW)

2. Outdoor Units

2-4. Electrical wiring diagram

AE090RXEDGG/EU

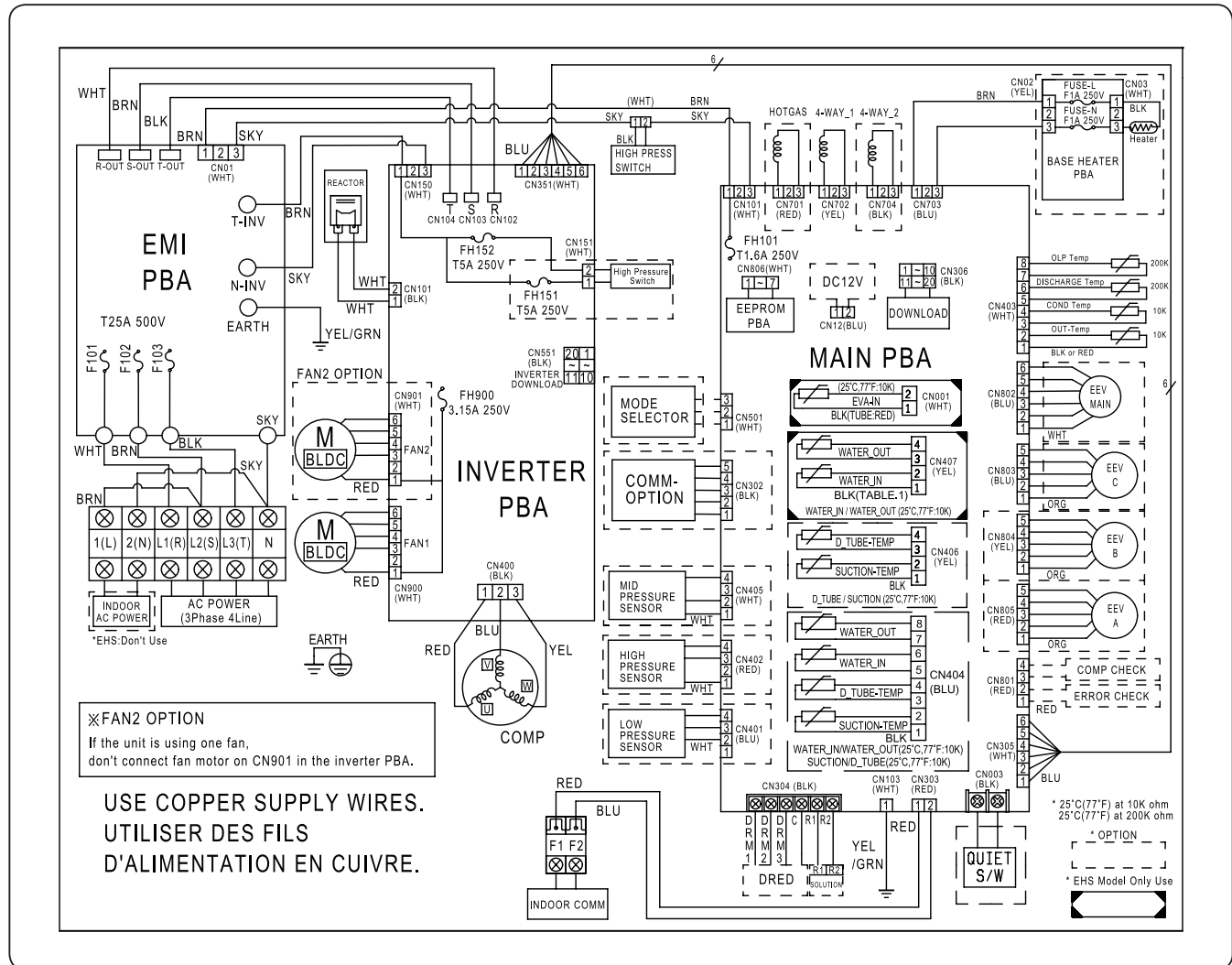

M BLDC	BLDC FAN MOTOR	COMP	COMPRESSOR
Comm	Communication	OUT-Temp	Thermistor OUT(10K)
COND-Temp	Thermistor COND(10K)	DISCHARGE-Temp	Thermistor DISCHARGE(200K)
OLP-Temp	Thermistor OLP(200K)	SUCTION-Temp	Thermistor SUCTION(10K)

NOTE

1. This wiring diagram applies only to the Outdoor unit.
2. Symbols show as follow :
 blk: black, red: red, blu: blue, wht: white, yel: yellow, brn: brown, sky: skyblue, grn: green
3. For connection wiring indoor-outdoor transmission F1-F2, indoor-wired remote controller transmission F3-F4.
4. Protective earth(SCREW)

2. Outdoor Units

2-5. Sound data

Summary

Capacity (kW)	Model	Sound Pressure dB(A)		Sound Power dB(A)
		Cooling	Heating	Heating
4.4	AE040RXEDEG/EU	46	44	58
6.0	AE060RXEDEG/EU	47	47	60
9.0	AE090RXEDEG/EU	49	49	64
9.0	AE090RXEDGG/EU	49	49	64

NOTE

- Specifications may be subject to change without prior notice.
- Sound Pressure Level
 - Sound pressure level is obtained in an anechoic room.
 - Sound pressure level is a relative value, depending on the distance and acoustic environment.
 - Sound pressure level may differ depending on operation condition.
 - dBA = A-weighted sound pressure level
 - Reference acoustic pressure 0 dB = 20μPa
- Sound Power Level
 - Sound power level is an absolute value that a sound source generates.
 - dBA = A-weighted sound power level.
 - Reference power : 1pW.
 - Measured according to ISO 3741.

2. Outdoor Units

2-5. Sound data

Sound Pressure level

Unit: dB(A)

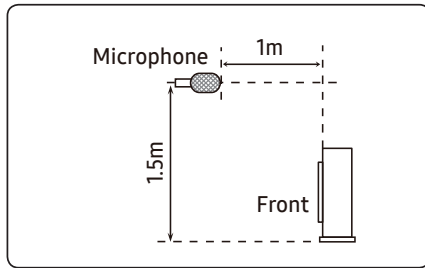

Model	Cooling	Heating
AE040RXEDEG/EU	46	44
AE060RXEDEG/EU	47	47
AE090RXEDEG/EU	49	49
AE090RXEDGG/EU	49	49

- NR Curve

1) AE040RXEDEG/EU

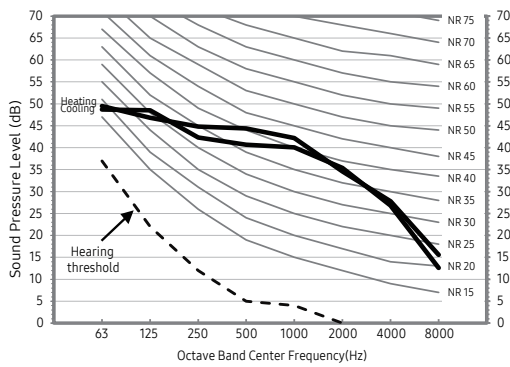

2) AE060RXEDEG/EU

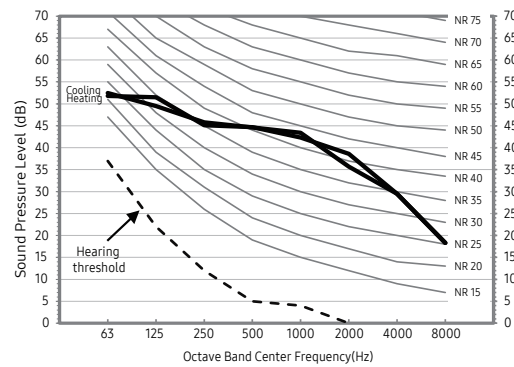

3) AE090RXEDEG/EU

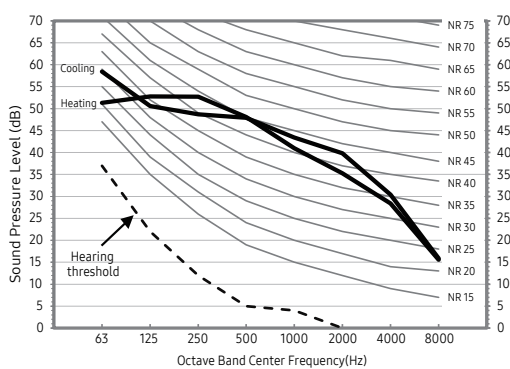

4) AE090RXEDGG/EU

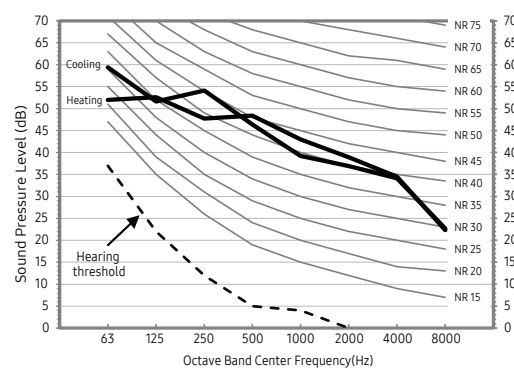

2. Outdoor Units

2-5. Sound data

Sound Power level

NOTE

- Specifications may be subject to change without prior notice
 - Sound power level is an absolute value that a sound source generates.
 - dBA = A-weighted sound power level.
 - Reference power : 1pW.
 - Measured according to ISO 3741.

Model	Power (dBA)
AE040RXEDEG/EU	58
AE060RXEDEG/EU	60
AE090RXEDEG/EU	64
AE090RXEDGG/EU	64

1) AE040RXEDEG/EU

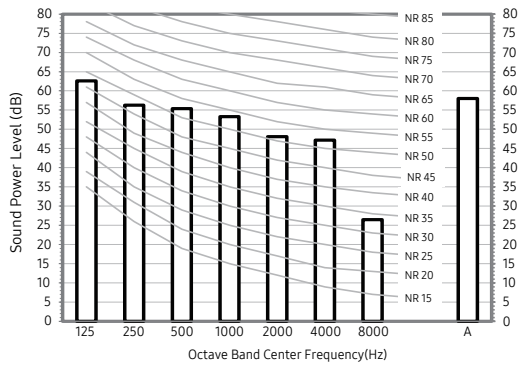

2) AE060RXEDEG/EU

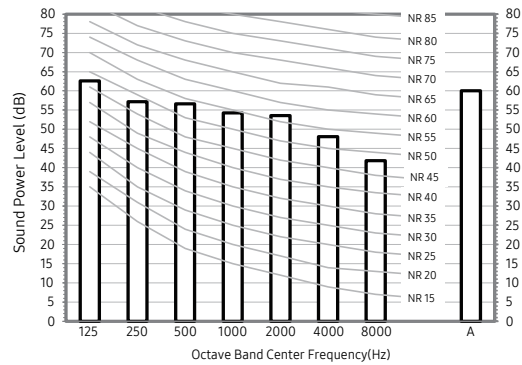

3) AE090RXEDEG/EU

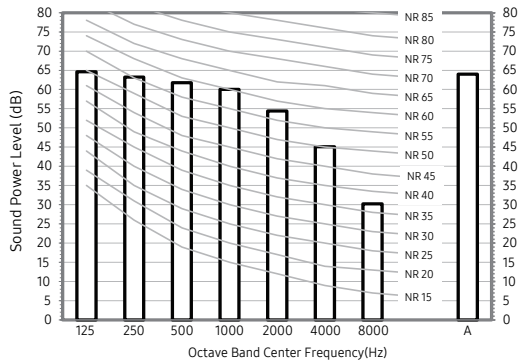

4) AE090RXEDGG/EU

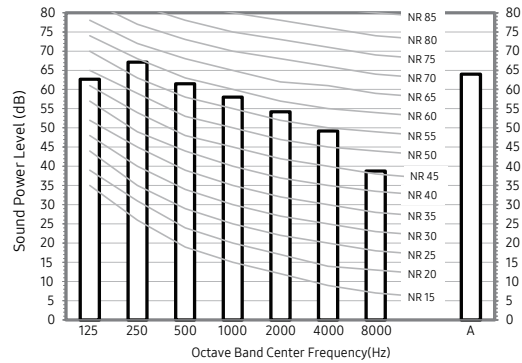

2. Outdoor Units

2-6. Operation range

1) Cooling

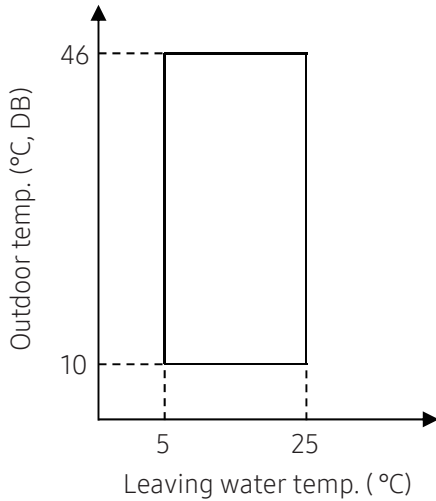

2) Heating

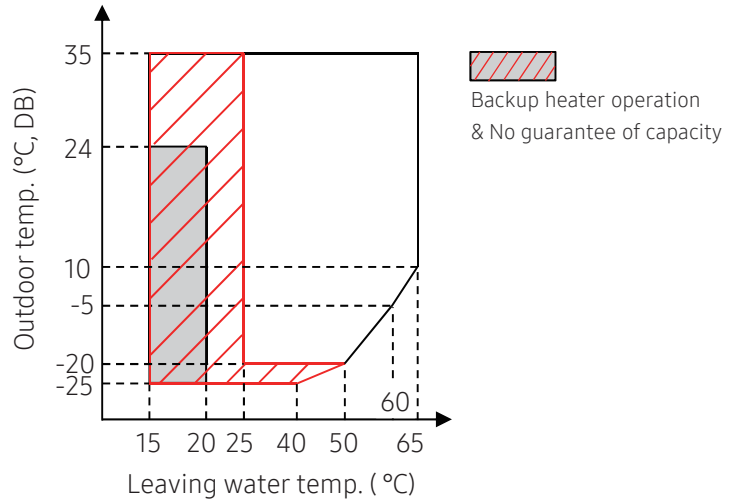

MONO Outdoor Unit		Water Temp. (°C)			Water Flow Rates (LPM)			Air Temp. (°C, DB/WB)		
		Min	Std	Max	Min	Std	Max	Min	Std	Max
Controller	Cooling	5	-	25	12 (7 ^{*1}) Δ 5°C 58 (48 ^{*1})			10/- 35/24 46/28		
	Heating	15	-	65						
Cooling	Inlet	-	23 (12 ^{*2})	30	12 (7 ^{*1}) Δ 5°C 58 (48 ^{*1})			10/- 35/24 46/28		
	Outlet	5	18 (7 ^{*2})	25						
Heating	Inlet	5	30 (40 ^{*2})	-	12 (7 ^{*1}) Δ 5°C 58 (48 ^{*1})			-25/- 7/6 35/24		
	Outlet	25 (15 ^{*3})	35 (45 ^{*2})	65						

*1) Model : AE040RXEDEC
 AE060RXEDEC
 AE090RXEDEC
 AE090RXEDGG

*2) Eurovent Test Condition #2

*3) Back up heater operation.

※ Operation of outdoor unit possible, but no guarantee of capacity in this condition.
 (-25°C ≤ Outdoor temp < -20°C)

3) DHW (Domestic Hot Water Tank)

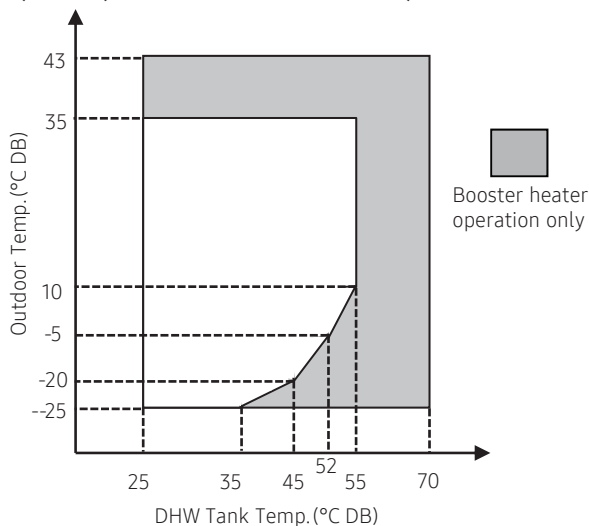

※ Special condition(35°C < Outdoor temp. ≤ 43°C) is operated by only Booster Heater.
 SAMSUNG doesn't supply DHW for EHS Split.
 Since it is a reference data, you have to check DHW operation range for yours.

2. Outdoor Units

2-7. Piping diagram

AE040/060RXEDEG/EU

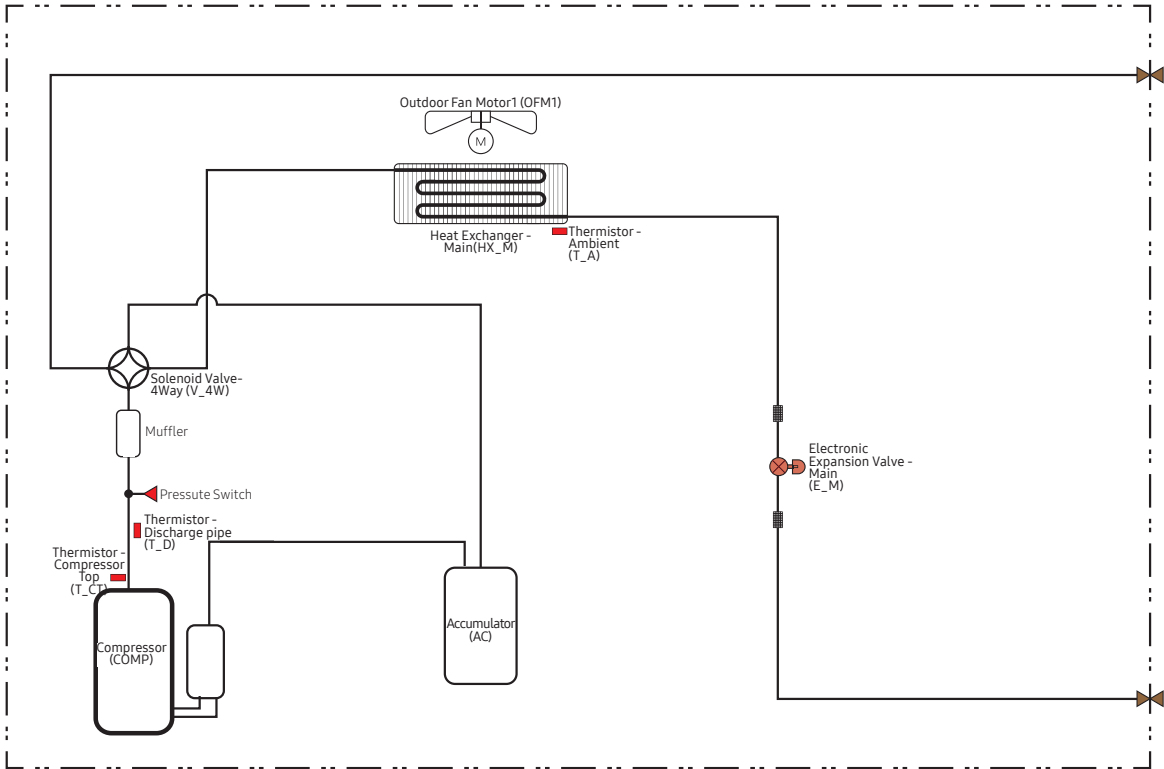

AE090RXED*G/EU

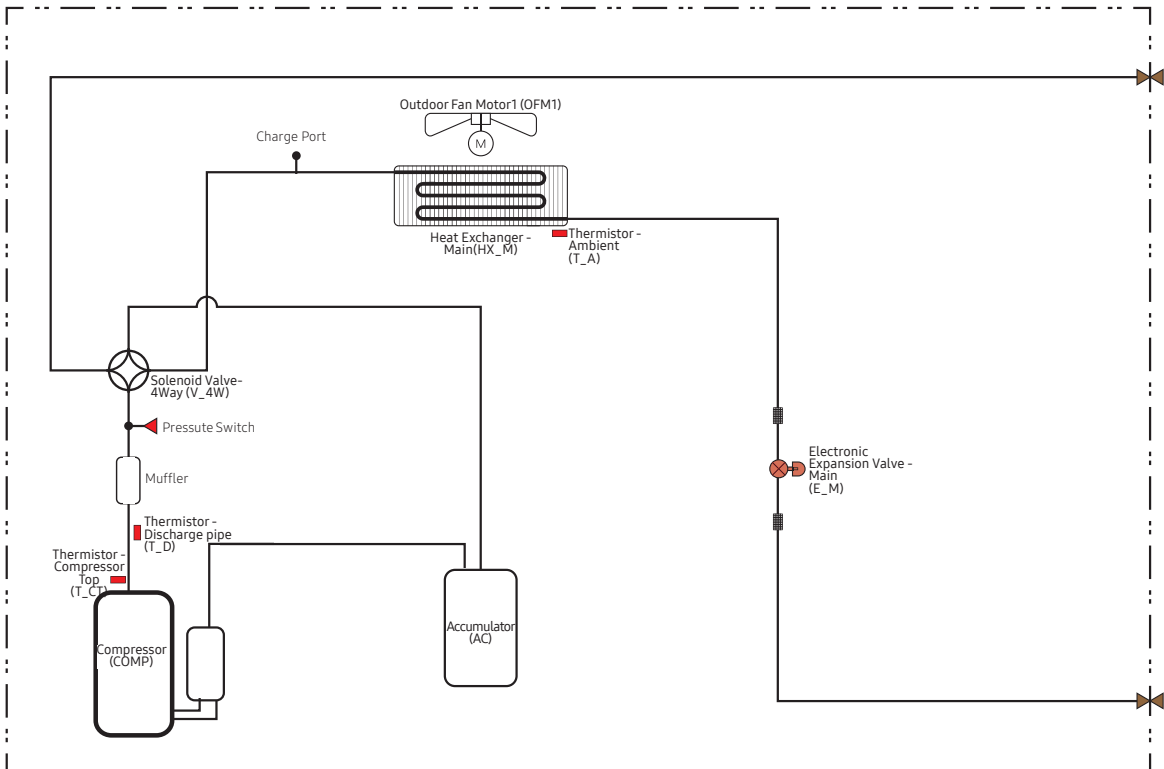

2. Outdoor Units

2-8. Capacity table

1) Maximum Heating Capacity (Peak Value)

LWT (Leaving Water Temp.), Tamb (Ambient Temp.), HC (Heating Capacity), PI (Power input)

Model	LWT(°C)	25		30		35		40		45		50		55		60		65		
	Tamb(°C)	HC(kW)	PI(kW)	HC(kW)	PI(kW)	HC(kW)	PI(kW)	HC(kW)	PI(kW)	HC(kW)	PI(kW)	HC(kW)	PI(kW)	HC(kW)	PI(kW)	HC(kW)	PI(kW)	HC(kW)	PI(kW)	
AE040RXEDEG	-20	3.57	1.27	3.65	1.37	3.30	1.51	3.24	1.59	3.21	1.72									
	-15	4.06	1.35	4.16	1.44	3.76	1.60	3.66	1.67	3.74	1.74	3.44	1.82							
	-10	4.97	1.46	4.83	1.55	4.60	1.71	4.46	1.73	4.32	1.84	4.19	1.93	3.89	2.48					
	-7	5.18	1.46	5.03	1.44	4.79	1.61	4.69	1.89	4.59	2.03	4.40	2.11	4.22	2.54					
	-2	5.40	1.25	5.25	1.34	5.00	1.51	4.81	1.65	4.62	1.80	4.39	1.89	4.16	1.98	3.94	2.18			
	2	5.27	1.06	5.13	1.14	4.88	1.28	4.61	1.35	4.34	1.43	4.12	1.60	3.91	1.78	3.70	1.89			
	7	4.75	0.70	4.62	0.75	4.40	0.85	4.30	1.00	4.20	1.09	4.05	1.27	3.90	1.32	3.57	1.45	3.44	1.58	
	10	5.09	0.73	4.95	0.78	4.71	0.88	4.61	1.00	4.57	1.15	4.34	1.30	4.11	1.51	3.79	1.55	3.55	1.60	
	15	5.68	0.74	5.47	0.81	5.21	0.91	5.12	1.02	5.14	1.18	4.88	1.33	4.72	1.51	4.35	1.56	4.08	1.62	
20	6.32	0.73	6.14	0.84	6.04	0.95	5.89	1.08	5.86	1.12	5.57	1.37	5.22	1.51	4.91	1.54	4.60	1.63		
AE060RXEDEG	-20	4.46	1.71	4.56	1.84	4.13	2.04	4.05	2.14	4.01	2.32									
	-15	5.08	1.81	5.20	1.94	4.70	2.15	4.57	2.25	4.67	2.34	4.30	2.46							
	-10	5.89	1.94	5.72	2.05	5.45	2.19	5.29	2.39	5.12	2.48	4.97	2.75	4.61	3.05					
	-7	6.19	1.83	6.02	1.85	5.73	2.08	5.61	2.45	5.49	2.62	5.27	2.79	5.05	3.06					
	-2	6.57	1.64	6.38	1.76	6.08	1.98	5.85	2.17	5.62	2.37	5.34	2.66	5.06	2.96	4.79	3.29			
	2	6.53	1.43	6.35	1.53	6.05	1.72	5.71	1.82	5.37	1.92	5.11	2.16	4.84	2.40	4.58	2.55			
	7	6.48	1.01	6.30	1.09	6.00	1.22	5.70	1.41	5.40	1.51	5.10	1.74	4.80	1.81	4.31	1.98	4.05	2.15	
	10	6.94	1.05	6.74	1.13	6.42	1.27	6.17	1.42	5.98	1.61	5.68	1.81	5.38	2.11	4.96	2.17	4.65	2.24	
	15	7.75	1.07	7.46	1.17	7.10	1.31	6.92	1.46	6.89	1.68	6.54	1.89	6.32	2.14	5.83	2.21	5.46	2.30	
20	8.62	1.05	8.38	1.21	8.23	1.37	8.03	1.55	8.00	1.61	7.60	1.98	7.12	2.18	6.70	2.22	6.28	2.35		
AE090RXED*G	-20	6.55	2.39	6.71	2.56	6.07	2.84	5.96	2.99	5.90	3.23									
	-15	7.47	2.53	7.64	2.71	6.91	3.00	6.72	3.14	6.87	3.26	6.33	3.43							
	-10	8.64	2.72	8.40	2.83	8.00	3.29	7.76	3.44	7.52	3.46	7.29	3.93	6.77	4.68					
	-7	8.89	2.65	8.64	2.69	8.23	3.02	8.05	3.51	7.88	3.80	7.56	4.04	7.25	4.89					
	-2	9.57	2.43	9.31	2.61	8.86	2.93	8.53	3.22	8.19	3.50	7.78	3.94	7.37	4.38	6.98	4.87			
	2	9.67	2.18	9.40	2.34	8.95	2.63	8.46	2.78	7.96	2.93	7.56	3.30	7.16	3.66	6.79	3.89			
	7	9.72	1.55	9.45	1.66	9.00	1.87	8.80	2.16	8.60	2.33	8.30	2.66	8.00	2.73	7.33	3.11	7.07	3.52	
	10	10.40	1.61	10.12	1.73	9.63	1.94	9.44	2.19	9.35	2.48	8.88	2.79	8.41	3.25	7.75	3.35	7.26	3.45	
	15	11.63	1.64	11.19	1.79	10.65	2.01	10.48	2.24	10.51	2.59	9.99	2.91	9.66	3.29	8.90	3.39	8.34	3.53	
20	12.93	1.61	12.57	1.85	12.35	2.10	12.05	2.38	12.00	2.47	11.40	3.03	10.69	3.33	10.05	3.41	9.42	3.61		

1. Heating capacity : Capacity is according to Eurovent rating standard OM-3-2015 and valid for heated water range $\Delta t = 3\sim 8^{\circ}\text{C}$
 2. Cooling capacity : Capacity is according to Eurovent rating standard OM-3-2015 and valid for chilled water range $\Delta t = 3\sim 8^{\circ}\text{C}$
 3. Power input : Power input is according to Eurovent rating standard OM-3-2015.
 4. Peak value : Tested without defrost operation in accordance with EN14511
- ※ The real capacity would be changed according to the install environment.

2. Outdoor Units

2-8. Capacity table

2) Maximum Heating Capacity (Integrated Value)

LWT (Leaving Water Temp.), Tamb (Ambient Temp.), HC (Heating Capacity), PI (Power input)

Model	LWT(°C)	25		30		35		40		45		50		55		60		65	
	Tamb(°C)	HC(kW)	PI(kW)	HC(kW)	PI(kW)	HC(kW)	PI(kW)	HC(kW)	PI(kW)	HC(kW)	PI(kW)	HC(kW)	PI(kW)	HC(kW)	PI(kW)	HC(kW)	PI(kW)	HC(kW)	PI(kW)
AE040RXEDEG	-20	3.57	1.27	3.65	1.37	3.30	1.51	3.24	1.59	3.21	1.72								
	-15	4.06	1.35	4.16	1.44	3.76	1.60	3.66	1.67	3.74	1.74	3.44	1.82						
	-10	4.63	1.38	4.50	1.46	4.28	1.64	4.15	1.73	4.03	1.81	3.82	1.80	3.62	2.39				
	-7	4.72	1.38	4.59	1.42	4.42	1.55	4.32	1.84	4.23	2.03	4.23	2.11	3.85	2.42				
	-2	4.51	1.15	4.39	1.18	4.22	1.33	4.15	1.53	3.95	1.67	3.71	1.75	3.48	1.83	3.30	2.02		
	2	4.31	0.96	4.15	1.01	3.95	1.13	3.81	1.20	3.60	1.29	3.48	1.45	3.33	1.61	3.02	1.79		
	7	4.75	0.70	4.62	0.75	4.40	0.85	4.30	1.00	4.20	1.09	4.05	1.27	3.90	1.32	3.57	1.45	3.44	1.58
	10	5.09	0.73	4.95	0.78	4.71	0.88	4.61	1.00	4.57	1.15	4.34	1.30	4.11	1.51	3.79	1.55	3.55	1.60
	15	5.68	0.74	5.47	0.81	5.21	0.91	5.12	1.02	5.14	1.18	4.88	1.33	4.72	1.51	4.35	1.56	4.08	1.62
20	6.32	0.73	6.14	0.84	6.04	0.95	5.89	1.08	5.86	1.12	5.57	1.37	5.22	1.51	4.91	1.54	4.60	1.63	
AE060RXEDEG	-20	4.46	1.71	4.56	1.84	4.13	2.04	4.05	2.14	4.01	2.32								
	-15	5.08	1.81	5.20	1.94	4.70	2.15	4.57	2.25	4.67	2.34	4.30	2.46						
	-10	5.48	1.87	5.33	1.97	5.07	2.19	4.92	2.33	4.77	2.43	4.53	2.68	4.29	2.94				
	-7	5.64	1.78	5.49	1.83	5.28	2.00	5.17	2.37	5.06	2.61	5.05	2.78	4.60	2.98				
	-2	5.49	1.52	5.34	1.55	5.14	1.74	5.04	2.01	4.80	2.19	4.51	2.46	4.23	2.73	4.00	3.04		
	2	5.34	1.29	5.13	1.36	4.89	1.52	4.71	1.61	4.46	1.73	4.30	1.95	4.12	2.17	3.74	2.41		
	7	6.48	1.01	6.30	1.09	6.00	1.22	5.70	1.41	5.40	1.51	5.10	1.74	4.80	1.81	4.31	1.98	4.05	2.15
	10	6.94	1.05	6.74	1.13	6.42	1.27	6.17	1.42	5.98	1.61	5.68	1.81	5.38	2.11	4.96	2.17	4.65	2.24
	15	7.75	1.07	7.46	1.17	7.10	1.31	6.92	1.46	6.89	1.68	6.54	1.89	6.32	2.14	5.83	2.21	5.46	2.30
20	8.62	1.05	8.38	1.21	8.23	1.37	8.03	1.55	8.00	1.61	7.60	1.98	7.12	2.18	6.70	2.22	6.28	2.35	
AE090RXED*G	-20	6.55	2.39	6.71	2.56	6.07	2.84	5.96	2.99	5.90	3.23								
	-15	7.47	2.53	7.64	2.71	6.91	3.00	6.72	3.14	6.87	3.26	6.33	3.43						
	-10	8.04	2.65	7.82	2.78	7.45	3.22	7.22	3.38	7.00	3.39	6.79	3.81	6.30	4.52				
	-7	8.11	2.58	7.88	2.66	7.58	2.90	7.42	3.44	7.26	3.79	7.26	4.04	6.61	4.78				
	-2	8.00	2.25	7.78	2.30	7.49	2.58	7.35	2.97	6.99	3.24	6.57	3.64	6.16	4.09	5.84	4.50		
	2	7.90	1.97	7.68	2.09	7.32	2.35	6.98	2.46	6.60	2.65	6.37	2.98	6.10	3.31	5.54	3.68		
	7	9.72	1.55	9.45	1.66	9.00	1.87	8.80	2.16	8.60	2.33	8.30	2.66	8.00	2.73	7.33	3.11	7.07	3.52
	10	10.40	1.61	10.12	1.73	9.63	1.94	9.44	2.19	9.35	2.48	8.88	2.79	8.41	3.25	7.75	3.35	7.26	3.45
	15	11.63	1.64	11.19	1.79	10.65	2.01	10.48	2.24	10.51	2.59	9.99	2.91	9.66	3.29	8.90	3.39	8.34	3.53
20	12.93	1.61	12.57	1.85	12.35	2.10	12.05	2.38	12.00	2.47	11.40	3.03	10.69	3.33	10.05	3.41	9.42	3.61	

1. Heating capacity : Capacity is according to Eurovent rating standard OM-3-2015 and valid for heated water range $\Delta t = 3\sim 8^{\circ}\text{C}$
 2. Cooling capacity : Capacity is according to Eurovent rating standard OM-3-2015 and valid for chilled water range $\Delta t = 3\sim 8^{\circ}\text{C}$
 3. Power input : Power input is according to Eurovent rating standard OM-3-2015.
 4. Integrated value : Tested with defrost operation in accordance with EN14511
- ※ The real capacity would be changed according to the install environment.

2. Outdoor Units

2-8. Capacity table

3) Cooling Capacity

LWT (Leaving Water Temp.), Tamb (Ambient Temp.), CC (Cooling Capacity), PI (Power input)

	LWT (°C)	7		10		13		15		18		25	
	Tamb (°C)	HC(kW)	PI(kW)	HC(kW)	PI(kW)	HC(kW)	PI(kW)	HC(kW)	PI(kW)	HC(kW)	PI(kW)	HC(kW)	PI(kW)
AE040RXEDEG	10	3.99	0.83	4.37	0.82	4.76	0.82	5.15	0.82	5.54	0.81	6.09	0.83
	20	3.83	0.94	4.21	0.93	4.58	0.93	4.95	0.93	5.33	0.92	5.86	0.94
	30	3.68	1.05	4.04	1.04	4.39	1.04	4.75	1.03	5.11	1.03	5.62	1.05
	35	3.60	1.11	3.95	1.11	4.30	1.10	4.65	1.10	5.00	1.09	5.50	1.11
	46	3.43	1.23	3.76	1.22	4.10	1.22	4.43	1.21	4.77	1.20	5.24	1.23
AE060RXEDEG	10	5.20	1.07	5.70	1.08	6.20	1.08	6.70	1.09	7.20	1.10	7.92	1.12
	20	5.01	1.22	5.48	1.22	5.96	1.23	6.44	1.24	6.92	1.24	7.61	1.27
	30	4.80	1.36	5.26	1.37	5.72	1.37	6.18	1.38	6.64	1.39	7.31	1.42
	35	4.70	1.44	5.15	1.45	5.60	1.46	6.05	1.46	6.50	1.47	7.15	1.50
	46	4.48	1.59	4.91	1.60	5.34	1.61	5.77	1.62	6.19	1.62	6.81	1.66
AE090RXED*G	10	7.20	1.45	7.80	1.48	8.41	1.51	9.02	1.54	9.63	1.57	10.59	1.60
	20	6.92	1.65	7.51	1.68	8.09	1.72	8.68	1.75	9.27	1.78	10.19	1.82
	30	6.64	1.84	7.21	1.88	7.77	1.92	8.33	1.96	8.89	1.99	9.78	2.03
	35	6.50	1.95	7.05	1.99	7.60	2.03	8.15	2.07	8.70	2.11	9.57	2.15
	46	6.19	2.15	6.72	2.20	7.24	2.24	7.77	2.29	8.29	2.33	9.12	2.38

1. Heating capacity is according to Eurovent rating standard OM-3-2015 and valid for heated water range $\Delta t = 3\text{--}8^{\circ}\text{C}$
 2. Cooling capacity is according to Eurovent rating standard OM-3-2015 and valid for chilled water range $\Delta t = 3\text{--}8^{\circ}\text{C}$
 3. Power input is total of indoor and outdoor unit, according to Eurovent rating standard OM-3-2015.
- ※ The real capacity would be changed according to the install environment.

2. Outdoor Units

2-9. Capacity correction

AE040/060RXEDEC/EU

1) Heating

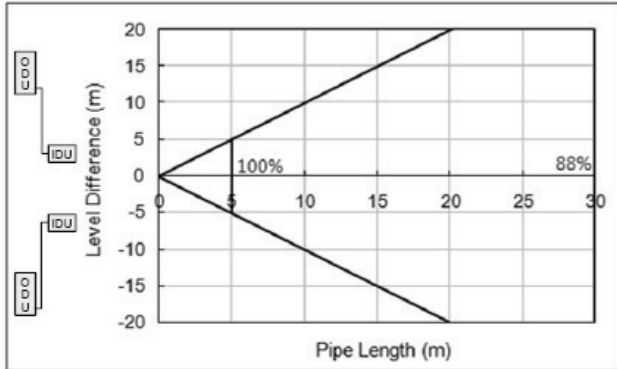

2) Cooling

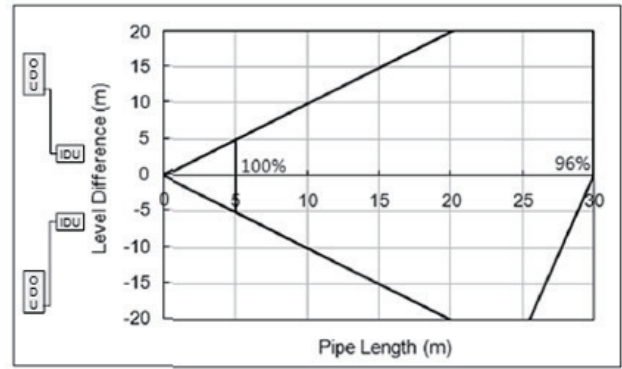

AE090RXED*G/EU

1) Heating

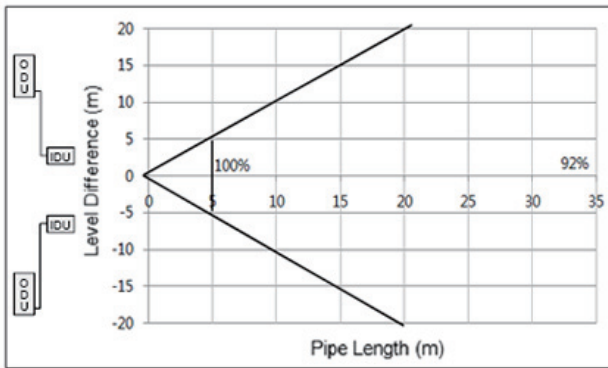

2) Cooling

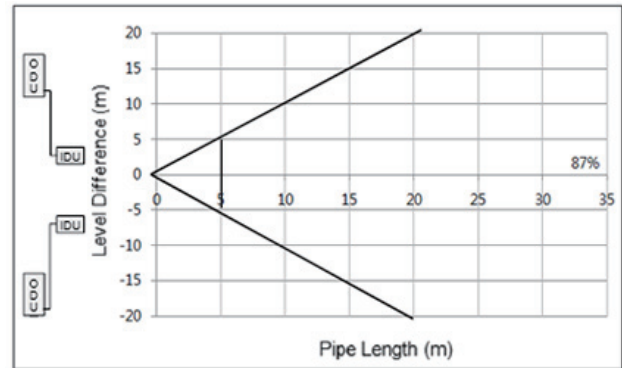

Silent mode corrections

Heating

Silent Function	Outdoor Air Temperature(°C DB)			
	-15	2	7	15
Level 1	0.92	0.87	0.94	0.94
Level 2	0.82	0.78	0.84	0.84
Level 3	0.68	0.64	0.69	0.69
Low-noise	0.7	0.6	0.69	0.69

Cooling

Silent Function	Outdoor Air Temperature(°C DB)			
	10	20	35	45
Level 1	1	1	0.92	0.92
Level 2	0.98	0.89	0.83	0.83
Level 3	0.81	0.74	0.68	0.68

3. Tank integrated hydro unit

3-1. Specifications

Model Name		Indoor Unit		AE200RNWSEG/EU	AE200RNWSEG/EU	AE200RNWSEG/EU
		Outdoor Unit		AE040RXEDEG/EU	AE060RXEDEG/EU	AE090RXEDEG/EU
Mode		-		Heat Pump (A2W)	Heat Pump (A2W)	Heat Pump (A2W)
Power Supply		Φ, #, V, Hz		1,2,220-240,50	1,2,220-240,50	1,2,220-240,50
Power input	Cooling (Nominal)	kW		0.2	0.2	0.2
	Heating (Nominal)	kW		0.2	0.2	0.2
	Cooling (Max)	kW		0.2	0.2	0.2
	Heating (Max)	kW		5.2	5.2	5.2
Current Input	Cooling (Nominal)	A		0.9	0.9	0.9
	Heating (Nominal)	A		0.9	0.9	0.9
	Cooling (Max)	A		0.9	0.9	0.9
	Heating (Max)	A		22.7	22.7	22.7
Field Wiring	MCA	A		22.7	22.7	22.7
	MFA			28.4	28.4	28.4
Heating up time		h / min		2 / 20	2 / 20	2 / 0
Water Heating	Declared load profile		-	L	L	L
	Energy efficiency Class		-	A+	A+	A+
Connections	Water Flow Rate (Std)[H/C]		LPM	12.7/14.4	17.3/18.8	26.0/25.1
	Water Flow Rate	Min	LPM	7.0	7.0	7.0
		Max	LPM	48.0	48.0	48.0
	Water Pressure (Max)		bar	3	3	3
	Refrigerant pipe (To outdoor unit)	Type	-	Flare nut	Flare nut	Flare nut
		Liquid	Φ, mm	6.35	6.35	6.35
		Gas	Φ, mm	15.88	15.88	15.88
	Water pipe (Space heating)	Type	-	Straight pipe	Straight pipe	Straight pipe
		Inlet	Φ, mm	28	28	28
		Outlet	Φ, mm	28	28	28
	Water pipe (DHW)	Type	-	Straight pipe	Straight pipe	Straight pipe
		Inlet	Φ, mm	22	22	22
		Outlet	Φ, mm	22	22	22
	Water pipe (Secondary water return, Only 260L optional)	Type	-	-	-	-
		Inlet	Φ, mm	-	-	-
Leaving Water Temperature	Heating	°C	15~65	15~65	15~65	
	Cooling	°C	5~25	5~25	5~25	
DHW Tank	Nominal Water Volume		liter	200	200	200
	Net Water Volume		liter	194	194	194
	Material		-	SUS 316L	SUS 316L	SUS 316L
	Max. water pressure		bar	10	10	10
	Max. water temperature		°C	70	70	70
	Immersion heater (= booster heater)		kW	3 (230V)	3 (230V)	3 (230V)
	Insulation		-	PU Foam	PU Foam	PU Foam
Water Pump	Type		-	Centrifurugal (UPMM 25-9.5)	Centrifurugal (UPMM 25-9.5)	Centrifurugal (UPMM 25-9.5)
	Motor Input		W	100	100	100
	Number of Unit		EA	1	1	1
Backup Heater	Power		kW	2 (230V)	2 (230V)	2 (230V)
	Thermostat (Thermal Fuse)		°C	65 (93)	65 (93)	65 (93)

3. Tank integrated hydro unit

3-1. Specifications

Model Name		Indoor Unit		AE200RNWSEG/EU	AE200RNWSEG/EU	AE200RNWSEG/EU
		Outdoor Unit		AE040RXEDEG/EU	AE060RXEDEG/EU	AE090RXEDEG/EU
Safety device	Pressure relief valve		bar	2.9	2.9	2.9
	Flow Sensor		LPM	5~60	5~60	5~60
	Temperature & Pressure relief valve (Tank)		bar, °C	7, 90	7, 90	7, 90
	Thermostat(for immersion heater)		°C	49~82±5 (Auto, On : 15°C±3°C↓)	49~82±5 (Auto, On : 15°C±3°C↓)	49~82±5 (Auto, On : 15°C±3°C↓)
Expansion vessel	Internal water volume		liter	8	8	8
	Working pressure		MPa	0.3	0.3	0.3
Water Pump (Primary)	Type		-	BLDC Inv	BLDC Inv	BLDC Inv
	Max static pressure		mAq	9.5	9.5	9.5
Water Heat Exchanger	Type		-	Braszed Plate Exchager	Braszed Plate Exchager	Braszed Plate Exchager
	Quantity		EA	1	1	1
	Internal water volume		L	1.01(Water Side) 0.98(Refrigerant Side)	1.01(Water Side) 0.98(Refrigerant Side)	1.01(Water Side) 0.98(Refrigerant Side)
	Water flow rate	Min.	l/min	7	7	7
		Max.	l/min	48	48	48
	Insulation material		-	EPS	EPS	EPS
IP Class			-	IPX1	IPX1	IPX1
Air Purge Valve			Φ, inch	BSPP male 3/8	BSPP male 3/8	BSPP male 3/8
Service Valve			Φ, inch	BSPP male 1 1/4	BSPP male 1 1/4	BSPP male 1 1/4
Sound	Sound Pressure	Heating	dB(A)	26	26	26
		Cooling	dB(A)	26	26	26
	Sound Power	Heating	dB(A)	40	40	40
Casing	Color		-	Earth brown	Earth brown	Earth brown
	Material		-	Poweder coated Galvanised steel	Poweder coated Galvanised steel	Poweder coated Electro galvanized steel
Packing	Material		-	EPS/BOX	EPS/BOX	EPS/BOX
	Packing Weight		kg	12.0	12.0	12.0
External Dimension	Net Weight		kg	136.0	136.0	136.0
	Shipping Weight		kg	148.0	148.0	148.0
	Net Dimensions (WxHxD)		mm	595 x 1,800 x 700	595 x 1,800 x 700	595 x 1,800 x 700
	Shipping Dimensions (WxHxD)		mm	700 x 2,000 x 780	700 x 2,000 x 780	700 x 2,000 x 780

NOTE

- Specifications may be subject to change without prior notice.

3. Tank integrated hydro unit

3-1. Specifications

Model Name		Indoor Unit		AE260RNWSGG/EU	AE260RNWSEG/EU	AE260RNWSEG/EU	AE260RNWSEG/EU
		Outdoor Unit		AE090RXEDGG/EU	AE040RXEDEG/EU	AE060RXEDEG/EU	AE090RXEDEG/EU
Mode		-		Heat Pump (A2W)	Heat Pump (A2W)	Heat Pump (A2W)	Heat Pump (A2W)
Power Supply		Φ, #, V, Hz		1,2,220-240,50 3,4,380-415,50	1,2,220-240,50	1,2,220-240,50	1,2,220-240,50
Power input	Cooling (Nominal)	kW		3Φ - / 1Φ 0.20	0.2	0.2	0.2
	Heating (Nominal)	kW		3Φ - / 1Φ 0.20	0.2	0.2	0.2
	Cooling (Max)	kW		3Φ - / 1Φ 0.20	0.2	0.2	0.2
	Heating (Max)	kW		3Φ 6.00 / 1Φ 3.20	5.2	5.2	5.2
Current Input	Cooling (Nominal)	A		3Φ - / 1Φ 0.9	0.9	0.9	0.9
	Heating (Nominal)	A		3Φ - / 1Φ 0.9	0.9	0.9	0.9
	Cooling (Max)	A		3Φ - / 1Φ 0.9	0.9	0.9	0.9
	Heating (Max)	A		3Φ 8.7 / 1Φ 14.0	22.7	22.7	22.7
Field Wiring	MCA	A		1Φ 14.0 / 3Φ 8.7	22.7	22.7	22.7
	MFA			11.6	28.4	28.4	28.4
Heating up time		h / min		1 / 35	2 / 50	2 / 50	1 / 35
Water Heating	Declared load profile		-	XL	XL	XL	XL
	Energy efficiency Class		-	A+	A+	A+	A+
Connections	Water Flow Rate (Std)[H/C]		LPM	26.0/25.1	12.7/14.4	17.3/18.8	26.0/25.1
	Water Flow Rate	Min	LPM	7.0	7.0	7.0	7.0
		Max	LPM	48.0	48.0	48.0	48.0
	Water Pressure (Max)		bar	3	3	3	3
	Refrigerant pipe (To outdoor unit)	Type	-	Flare nut	Flare nut	Flare nut	Flare nut
		Liquid	Φ, mm	6.35	6.35	6.35	6.35
		Gas	Φ, mm	15.88	15.88	15.88	15.88
	Water pipe (Space heating)	Type	-	Straight pipe	Straight pipe	Straight pipe	Straight pipe
		Inlet	Φ, mm	28	28	28	28
		Outlet	Φ, mm	28	28	28	28
	Water pipe (DHW)	Type	-	Straight pipe	Straight pipe	Straight pipe	Straight pipe
		Inlet	Φ, mm	22	22	22	22
		Outlet	Φ, mm	22	22	22	22
	Water pipe (Secondary water return, Only 260L optional)	Type	-	Straight pipe	Straight pipe	Straight pipe	Straight pipe
Inlet		Φ, mm	22	22	22	22	
Leaving Water Temperature	Heating	°C	15~65	15~65	15~65	15~65	
	Cooling	°C	5~25	5~25	5~25	5~25	
DHW Tank	Nominal Water Volume		liter	260	260	260	260
	Net Water Volume		liter	254	254	254	254
	Material		-	SUS 316L	SUS 316L	SUS 316L	SUS 316L
	Max. water pressure		bar	10	10	10	10
	Max. water temperature		°C	70	70	70	70
	Immersion heater (= booster heater)		kW	3 (230V)	3 (230V)	3 (230V)	3 (230V)
	Insulation		-	PU Foam	PU Foam	PU Foam	PU Foam
Water Pump	Type		-	Centrifurugal (UPMM 25-9.5)	Centrifurugal (UPMM 25-9.5)	Centrifurugal (UPMM 25-9.5)	Centrifurugal (UPMM 25-9.5)
	Motor Input		W	100	100	100	100
	Number of Unit		EA	1	1	1	1
Backup Heater	Power		kW	6 (3Φ 400V)	2 (230V)	2 (230V)	2 (230V)
	Thermostat (Thermal Fuse)		°C	75(93)	75(93)	75(93)	75(93)

3. Tank integrated hydro unit

3-1. Specifications

Model Name		Indoor Unit		AE260RNWSGG/EU	AE260RNWSEG/EU	AE260RNWSEG/EU	AE260RNWSEG/EU
		Outdoor Unit		AE090RXEDGG/EU	AE040RXEDEG/EU	AE060RXEDEG/EU	AE090RXEDEG/EU
Safety device	Pressure relief valve		bar	2.9	2.9	2.9	2.9
	Flow Sensor		LPM	5~60	5~60	5~60	5~60
	Temperature & Pressure relief valve (Tank)		bar, °C	7, 90	7, 90	7, 90	7, 90
	Thermostat(for immersion heater)		°C	49-82±5 (Auto, On : 15°C±3°C ↓)	49-82±5 (Auto, On : 15°C±3°C ↓)	49-82±5 (Auto, On : 15°C±3°C ↓)	49-82±5 (Auto, On : 15°C±3°C ↓)
Expansion vessel	Internal water volume		liter	8	8	8	8
	Working pressure		MPa	0.3	0.3	0.3	0.3
Water Pump (Primary)	Type		-	BLDC Inv	BLDC Inv	BLDC Inv	BLDC Inv
	Max static pressure		mAq	9.5	9.5	9.5	9.5
Water Heat Exchanger	Type		-	Braszed Plate Exchanger	Braszed Plate Exchanger	Braszed Plate Exchanger	Braszed Plate Exchanger
	Quantity		EA	1	1	1	1
	Internal water volume		L	1.01(Water Side) 0.98(Refrigerant Side)	1.01(Water Side) 0.98(Refrigerant Side)	1.01(Water Side) 0.98(Refrigerant Side)	1.01(Water Side) 0.98(Refrigerant Side)
	Water flow rate	Min.	l/min	7	7	7	7
		Max.	l/min	48	48	48	48
Insulation material		-	EPS	EPS	EPS	EPS	
IP Class			-	IPX1	IPX1	IPX1	IPX1
Air Purge Valve			Φ, inch	BSPP male 3/8	BSPP male 3/8	BSPP male 3/8	BSPP male 3/8
Service Valve			Φ, inch	N/A	N/A	N/A	N/A
Sound	Sound Pressure	Heating	dB(A)	26	26	26	26
		Cooling	dB(A)	26	26	26	26
	Sound Power	Heating	dB(A)	40	40	40	40
Casing	Color		-	Earth brown	Earth brown	Earth brown	Earth brown
	Material		-	Powder coated Electro galvanized steel	Powder coated Galvanized steel	Powder coated Galvanized steel	Powder coated Electro galvanized steel
Packing	Material		-	EPS/BOX	EPS/BOX	EPS/BOX	EPS/BOX
	Packing Weight		kg	12.0	12.0	12.0	12.0
External Dimension	Net Weight		kg	146.0	146.0	146.0	146.0
	Shipping Weight		kg	158.0	158.0	158.0	158.0
	Net Dimensions (WxHxD)		mm	595 x 1,800 x 700	595 x 1,800 x 700	595 x 1,800 x 700	595 x 1,800 x 700
	Shipping Dimensions (WxHxD)		mm	700 x 2,000 x 780	700 x 2,000 x 780	700 x 2,000 x 780	700 x 2,000 x 780

NOTE

- Specifications may be subject to change without prior notice.

3. Tank integrated hydro unit

3-2. Dimensional drawing

AE200/260RNWS*G/EU

Unit : mm

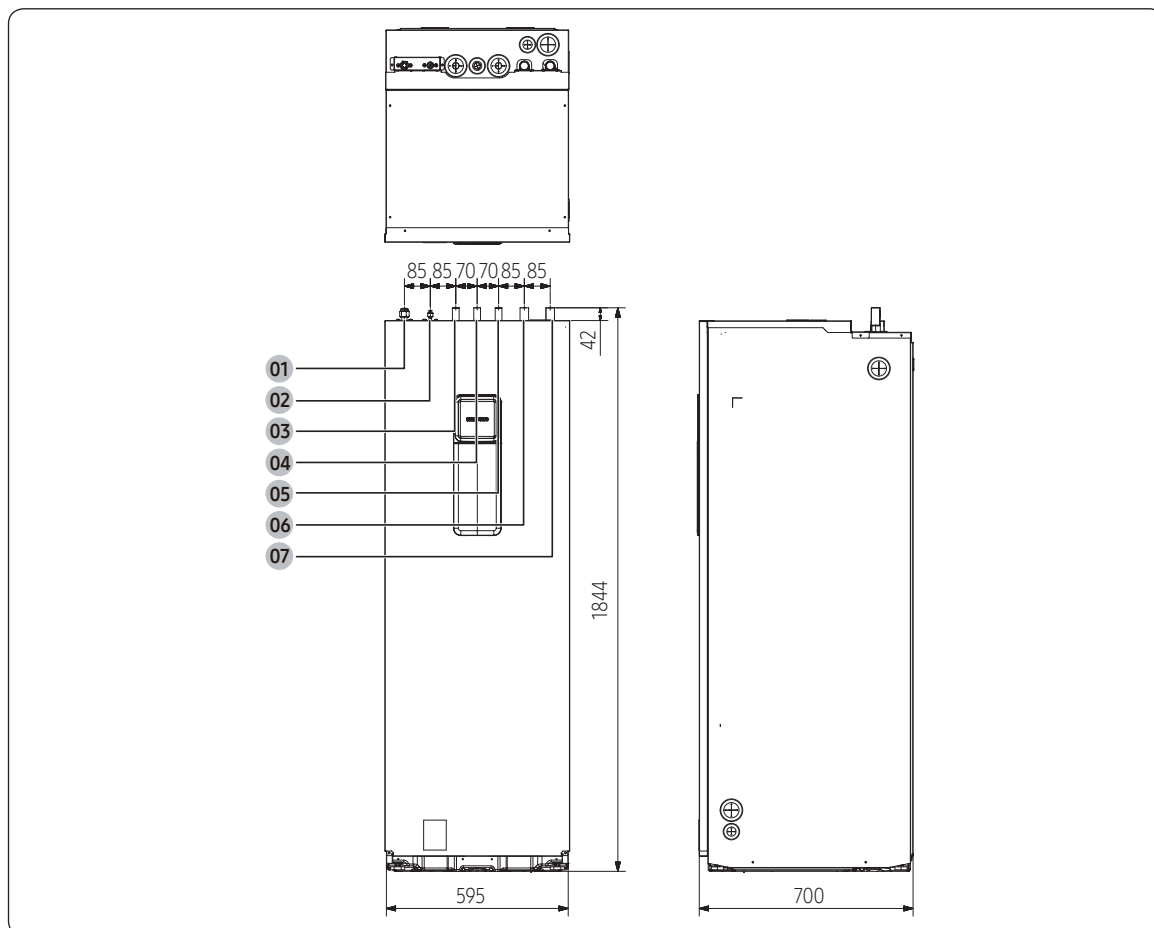

NO	Part name	Size
01	Refrigerant (Gas)	Ø15.88
02	Refrigerant (Liquid)	Ø6.35
03	Hot water outlet	Ø22, T1.0
04	Secondary return (260 L option)	Ø22, T1.0
05	Cold water inlet	Ø22, T1.0
06	Space heating outlet	Ø28, T1.2
07	Space heating inlet	Ø28, T1.2

3. Tank integrated hydro unit

3-2. Dimensional drawing

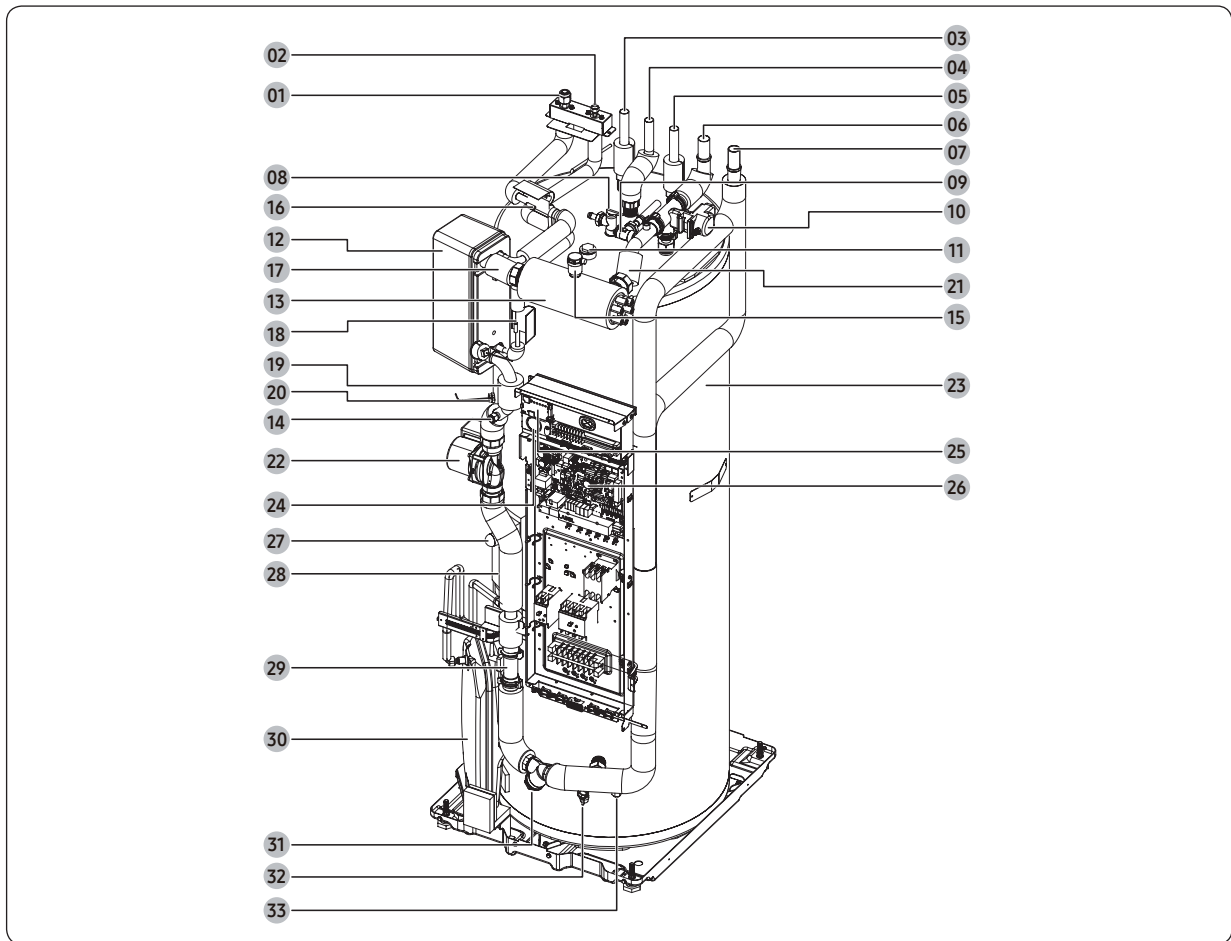

NO	Part name	Note	NO	Part name	Note
01	Refrigerant pipe	ø15.88 (5/8"), Flare nut	18	Eva-out thermistor	
02	Refrigerant pipe	ø6.35 (1/4"), Flare nut	19	Water-in thermistor	
03	Hot water outlet	ø22, Straight pipe	20	Tank thermistor	
04	Secondary return	ø22, Straight pipe (260 L option)	21	Heater thermistor	
05	Cold water inlet	ø22, Straight pipe	22	Water pump	
06	Space heating outlet	ø28, Straight pipe	23	Water tank	200 L / 260 L
07	Space heating inlet	ø28, Straight pipe	24	Manometer	0~4 bar
08	T/P valve	7 bar, 90°C	25	S/D converter	
09	Pressure relief valve	3 bar, BSPP1/2"	26	Control box	
10	3-way valve		27	Booster heater	3kW
11	Anode bar	BSPP1"	28	Booster heater thermostat	
12	Plate heat exchanger		29	Flow sensor	
13	Back-up heater		30	Expasion vessel	8 L, Pre-charge gas: 0.1 MPa, N2, BSPP 3/8"
14	Drain port		31	Strainer	
15	Air vent	BSPP 3/8"	32	Tank drain valve	
16	Eva-in thermistor		33	Drain port	Primary circuit
17	Water-out thermistor				

3. Tank integrated hydro unit

3-3. Electrical wiring diagram

AE200RNWSEG/EU, AE260RNWSEG/EU

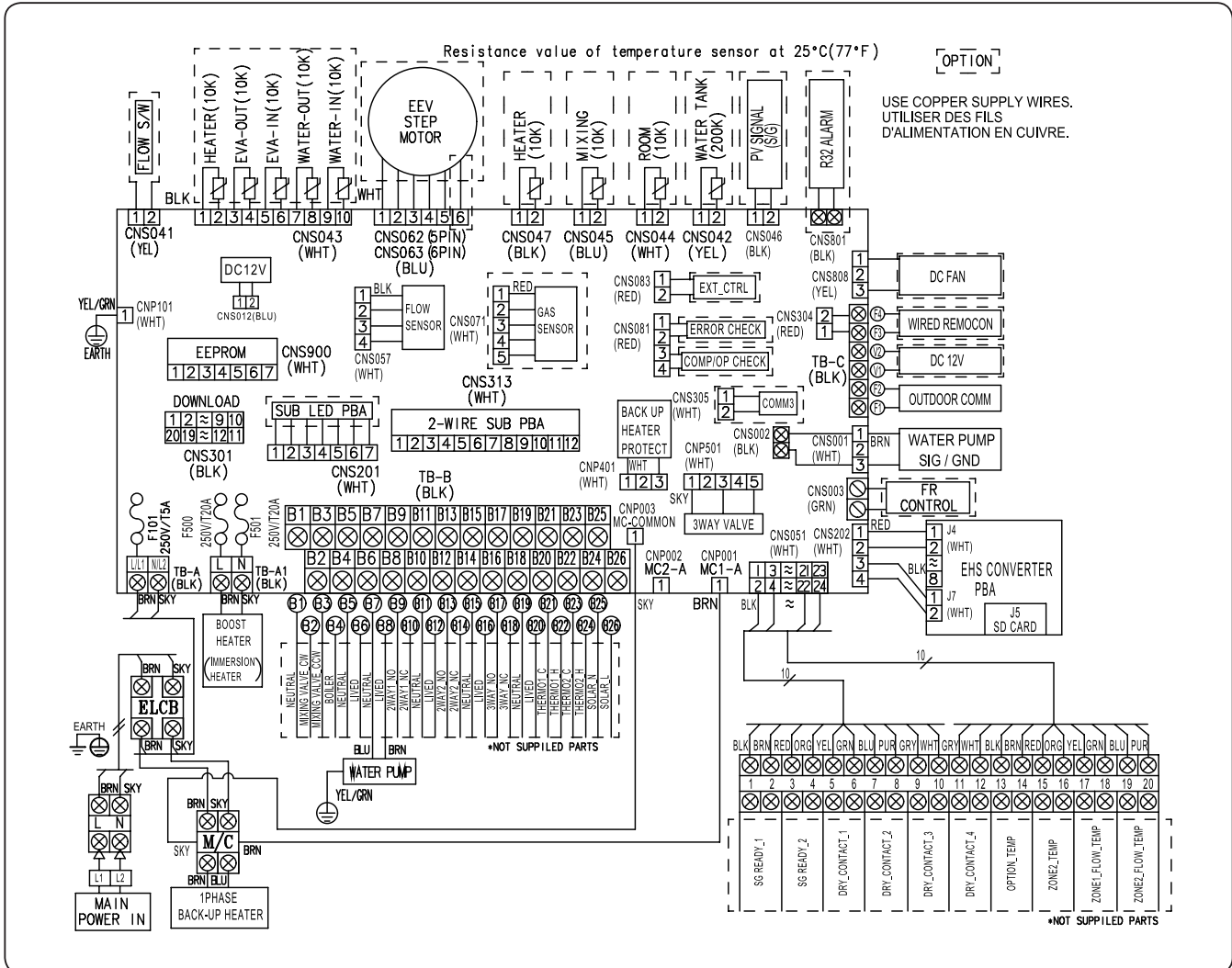

※ It does not support external input(CNS083)/output(CNS081) signal function

HEATER	Thermistor HEATER(10K)	EVA-OUT	Thermistor EVA-OUT(10K)
EVA-IN	Thermistor EVA-IN(10K)	WATER-OUT	Thermistor WATER-OUT(10K)
WATER-IN	Thermistor WATER-IN(10K)	WATER TANK	Thermistor WATER TANK(200K)
MIXING	Thermistor MIXING VALVE(10K)	WIRED REMOCON	Wired Remote Controller
OUTDOOR COMM	Outdoor Communication	SIG/GND	Signal/Ground
ELCB	Earth Leakage Circuit Breaker	M/C	Magnetic Contactor

NOTE

1. This wiring diagram applies only to the Indoor unit.
2. Symbols show as follow :
blk: black, red: red, blu: blue, wht: white, yel: yellow, brn: brown, sky: skyblue, grn: green
3. For connection wiring indoor-outdoor transmission F1-F2, indoor-wired remote controller transmission F3-F4.
4. (⊕) Protective earth(SCREW)

3. Tank integrated hydro unit

3-3. Electrical wiring diagram

AE260RNWSGG/EU

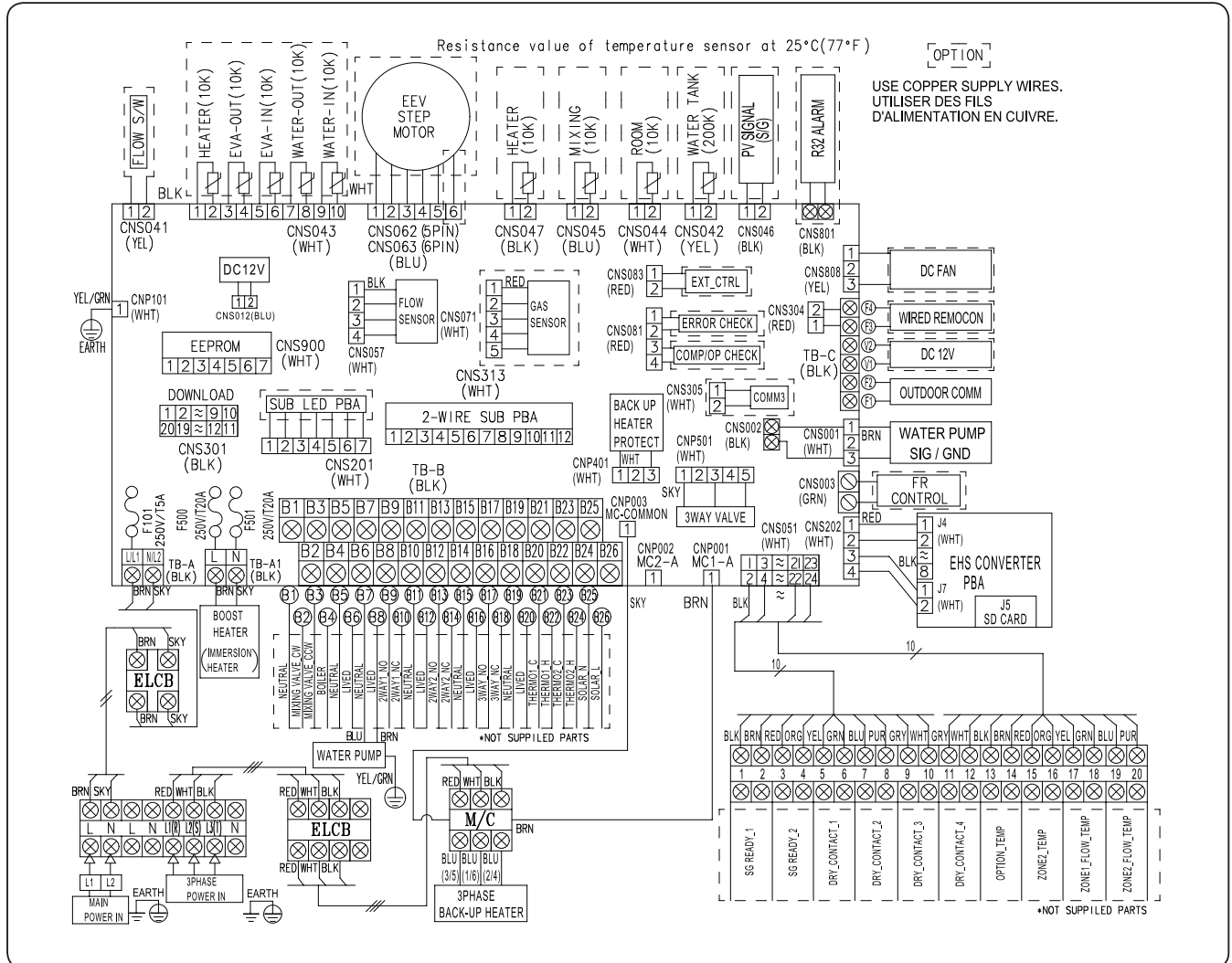

* It does not support external input(CNS083)/output(CNS081) signal function

HEATER	Thermistor HEATER(10K)	EVA-OUT	Thermistor EVA-OUT(10K)
EVA-IN	Thermistor EVA-IN(10K)	WATER-OUT	Thermistor WATER-OUT(10K)
WATER-IN	Thermistor WATER-IN(10K)	WATER TANK	Thermistor WATER TANK(200K)
MIXING	Thermistor MIXING VALVE(10K)	WIRED REMOCON	Wired Remote Controller
OUTDOOR COMM	Outdoor Communication	SIG/GND	Signal/Ground
ELCB	Earth Leakage Circuit Breaker	M/C	Magnetic Contactor

NOTE

1. This wiring diagram applies only to the Indoor unit.
2. Symbols show as follow :
blk: black, red: red, blu: blue, wht: white, yel: yellow, brn: brown, sky: skyblue, grn: green
3. For connection wiring indoor-outdoor transmission F1-F2, indoor-wired remote controller transmission F3-F4.
4. ⚡ Protective earth(SCREW)

3. Tank integrated hydro unit

3-4. Sound data

Summary

Capacity (Liter)	Model	Sound Pressure dB(A) (Heating)	Sound Power dB(A) (Heating)
200	AE200RNWSEG/EU+AE040RXEDEG/EU	26	40
	AE200RNWSEG/EU+AE060RXEDEG/EU	26	40
	AE200RNWSEG/EU+AE090RXEDEG/EU	26	40
260	AE260RNWSSGG/EU+AE090RXEDGG/EU	26	40
260	AE260RNWSEG/EU + AE040RXEDEG/EU	26	40
	AE260RNWSEG/EU + AE060RXEDEG/EU	26	40
	AE260RNWSEG/EU + AE090RXEDEG/EU	26	40

NOTE

- Specifications may be subject to change without prior notice.
- Sound Pressure Level
 - Sound pressure level is obtained in an anechoic room.
 - Sound pressure level is a relative value, depending on the distance and acoustic environment.
 - Sound pressure level may differ depending on operation condition.
 - dBA = A-weighted sound pressure level
 - Reference acoustic pressure 0 dB = 20μPa
- Sound Power Level
 - Sound power level is an absolute value that a sound source generates.
 - dBA = A-weighted sound power level.
 - Reference power : 1pW.
 - Measured according to ISO 3741.

3. Tank integrated hydro unit

3-4. Sound data

Sound Pressure level

Unit: dB(A)

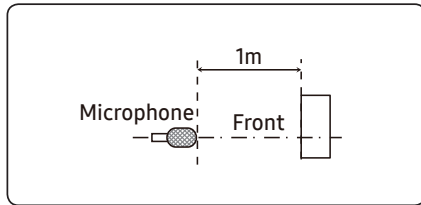

Model	Heating
AE200RNWSEG/EU+AE040RXEDEG/EU	26
AE200RNWSEG/EU+AE060RXEDEG/EU	26
AE200RNWSEG/EU+AE090RXEDEG/EU	26
AE260RNWSGG/EU+AE090RXEDGG/EU	26

• NR Curve

1) AE200RNWSEG/EU+AE040RXEDEG/EU

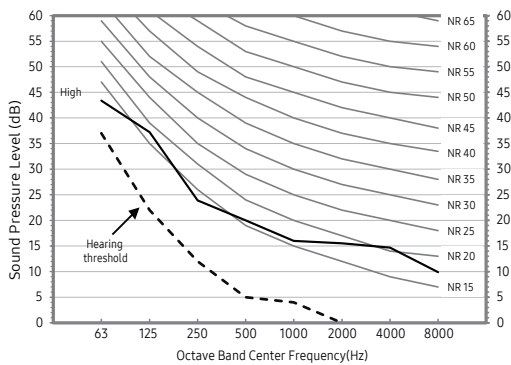

2) AE200RNWSEG/EU+AE060RXEDEG/EU

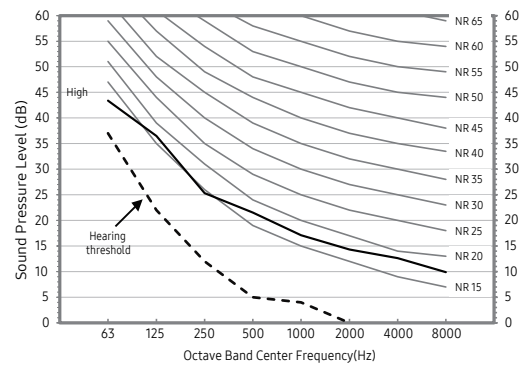

3) AE200RNWSEG/EU+AE090RXEDEG/EU

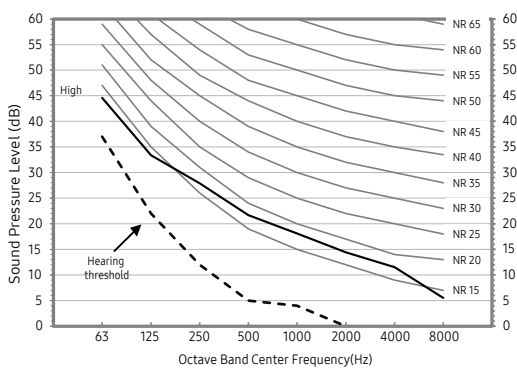

4) AE260RNWSGG/EU+AE090RXEDGG/EU

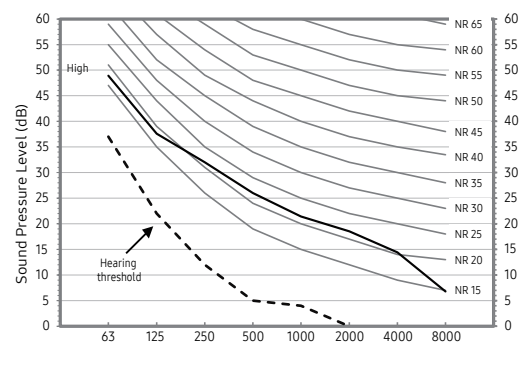

NOTE

- Specifications may be subject to change without prior notice.
- Sound Pressure Level
 - Sound pressure level is obtained in an anechoic room.
 - Sound pressure level is a relative value, depending on the distance and acoustic environment.
 - Sound pressure level may differ depending on operation condition.
 - dBA = A weighted sound pressure level
 - Reference acoustic pressure 0 dB = 20μPa

3. Tank integrated hydro unit

3-4. Sound data

Sound Pressure level

Unit: dB(A)

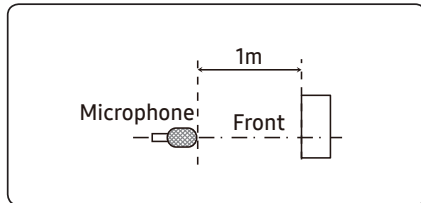

Model	Heating
AE260RNWSEG/EU + AE040RXEDEG/EU	26
AE260RNWSEG/EU + AE060RXEDEG/EU	26
AE260RNWSEG/EU + AE090RXEDEG/EU	26

- NR Curve

1) AE260RNWSEG/EU + AE040RXEDEG/EU

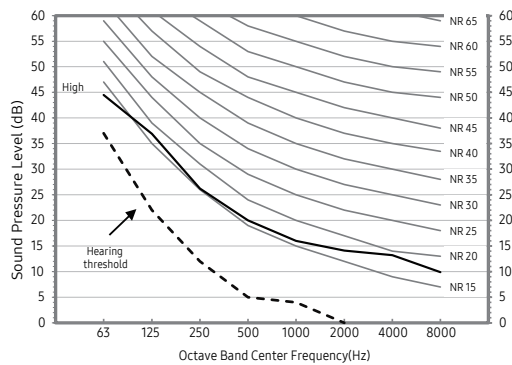

2) AE260RNWSEG/EU + AE060RXEDEG/EU

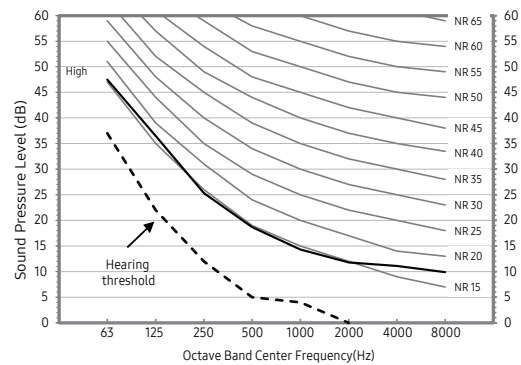

3) AE260RNWSEG/EU + AE090RXEDEG/EU

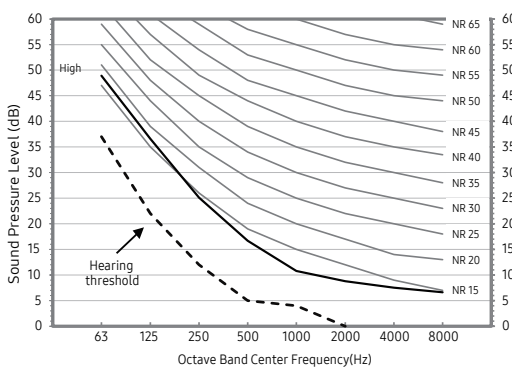

NOTE

- Specifications may be subject to change without prior notice.
- Sound Pressure Level
 - Sound pressure level is obtained in an anechoic room.
 - Sound pressure level is a relative value, depending on the distance and acoustic environment.
 - Sound pressure level may differ depending on operation condition.
 - dBA = A weighted sound pressure level
 - Reference acoustic pressure 0 dB = 20μPa

3. Tank integrated hydro unit

3-4. Sound data

Sound Power level

NOTE

- Specifications may be subject to change without prior notice
- Sound power level is an absolute value that a sound source generates.
- dBA = A-weighted sound power level.
- Reference power : 1pW.
- Measured according to ISO 3741.

Model	Power (dBA)
AE200RNWSEG/EU+AE040RXEDEG/EU	40
AE200RNWSEG/EU+AE060RXEDEG/EU	40
AE200RNWSEG/EU+AE090RXEDEG/EU	40
AE260RNWSGG/EU+AE090RXEDGG/EU	40

1) AE200RNWSEG/EU+AE040RXEDEG/EU

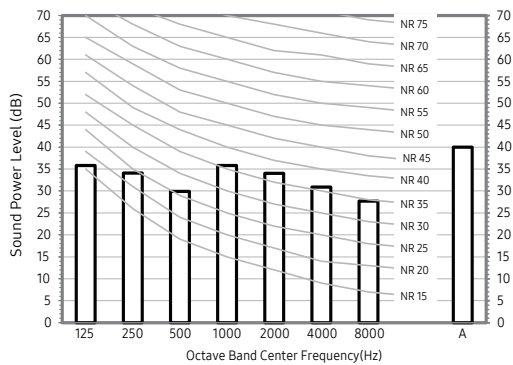

2) AE200RNWSEG/EU+AE060RXEDEG/EU

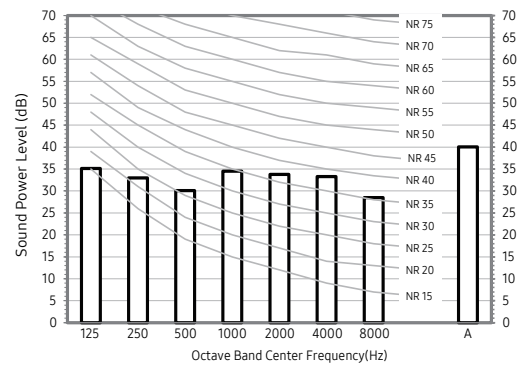

3) AE200RNWSEG/EU+AE090RXEDEG/EU

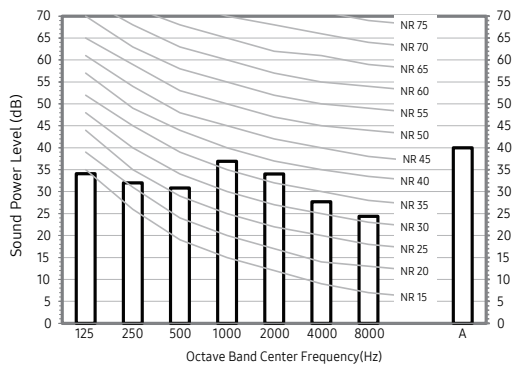

4) AE260RNWSGG/EU+AE090RXEDGG/EU

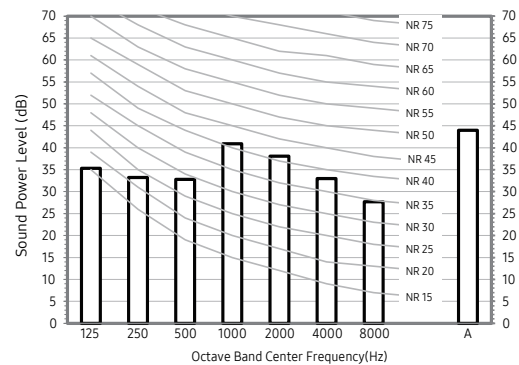

3. Tank integrated hydro unit

3-4. Sound data

Sound Power level

NOTE

- Specifications may be subject to change without prior notice
 - Sound power level is an absolute value that a sound source generates.
 - dBA = A-weighted sound power level.
 - Reference power : 1pW.
 - Measured according to ISO 3741.

Model	Power (dBA)
AE260RNWSEG/EU + AE040RXEDEG/EU	40
AE260RNWSEG/EU + AE060RXEDEG/EU	40
AE260RNWSEG/EU + AE090RXEDEG/EU	40

1) AE260RNWSEG/EU + AE040RXEDEG/EU

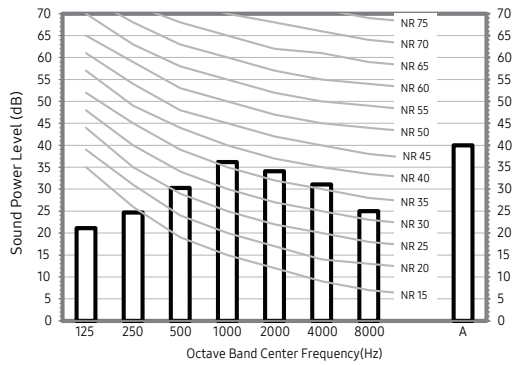

2) AE260RNWSEG/EU + AE060RXEDEG/EU

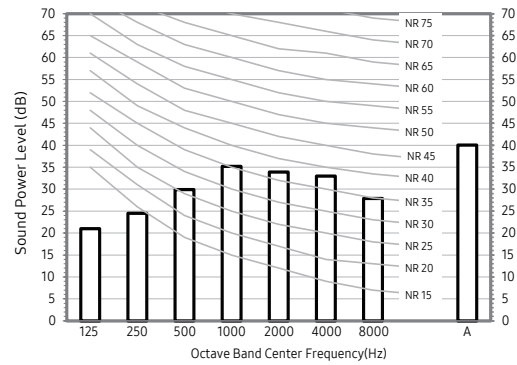

3) AE260RNWSEG/EU + AE090RXEDEG/EU

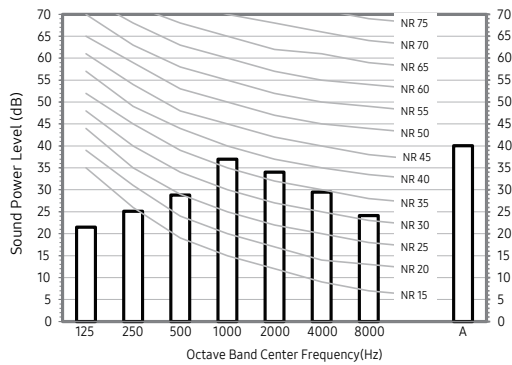

3. Tank integrated hydro unit

3-5. Piping diagram

AE200/260RNWS*G/EU

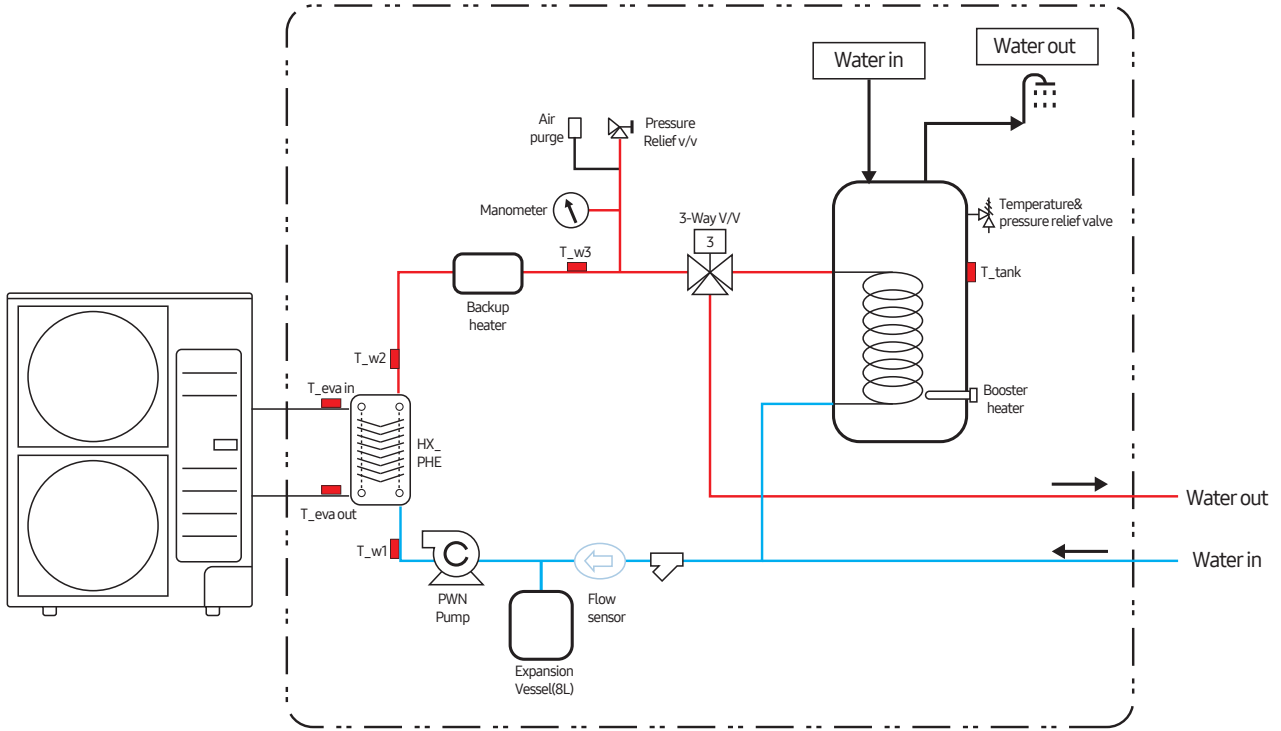

4. Installation

Tank integrated hydro unit

Application 1: Space heating + water heating

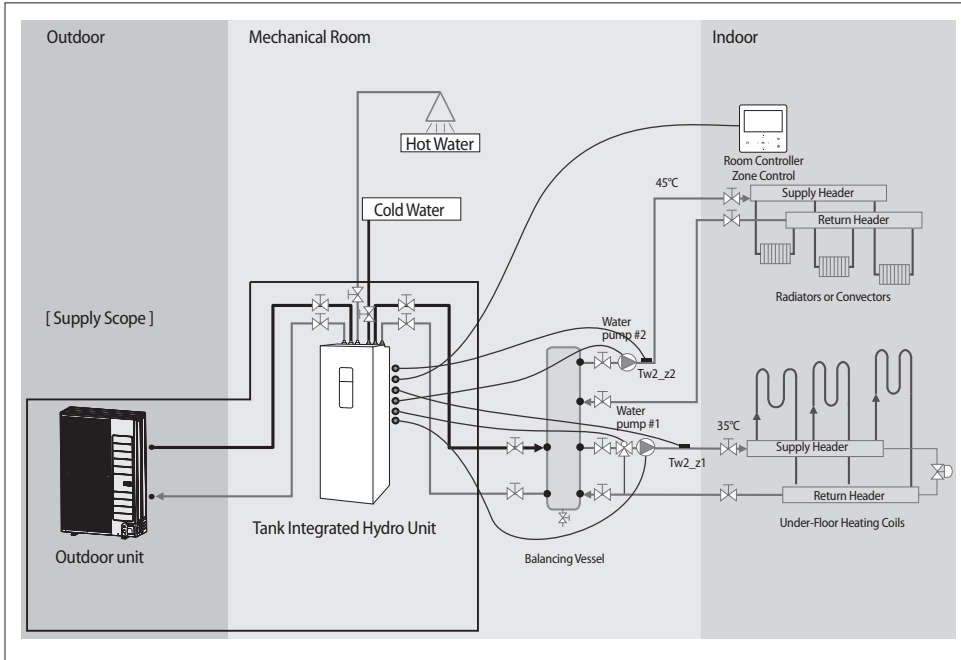

Application 2: Hybrid application (backup boiler and solar panel connected)

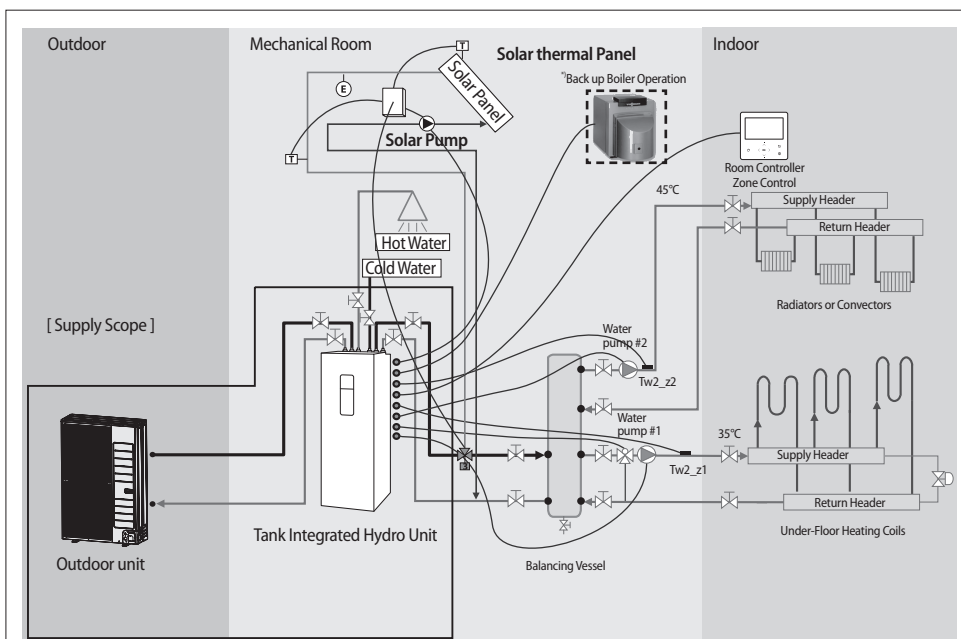

*) We control only the on / off signal of backup boiler according to outdoor temperature.
Backup boiler should be installed with own device according to the field condition.

※ In case you want more information about the controllers and accessories, please refer to the Controller and Accessory TDB on pvi.Samsung.com site or Global Partner Portal site.

4. Installation

Tank integrated hydro unit

Installation of mixing valve

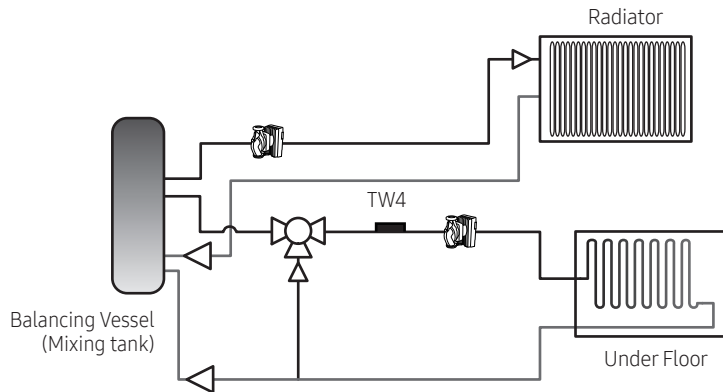

When two different zones are used with different temperature, adjust the temperature of discharge water to high temperature water and control the amount of bypass to provide low temperature water by applying the mixing valve and temperature sensor of the mixing valve (TW4).

1. Select a mixing valve from the manufacturers as below (recommended) and install it at the entrance of the zone.
2. Install the supplied temperature sensor (TW4) on the rear part of the mixing valve. Install TW4 Sensor within 1m of Mixing Valve.
3. Since running time varies depending on the manufacturer, set the FSV (default 90 sec.) by referring to the FSV value below.

Maker		BELIMO	SIEMENS	HONEYWELL
Model code	3 Way Valve	R3020-6P3-S2	VXP45.20-4 (kvs 4)	V5011E1213
	Actuator	LR230A(-S)	SSB31	ML6420A3015
Running time		90 sec.	150 sec.	60 sec.
FSV(#4046) setting		9	15	6

※ The table above is for your reference. It can be changed without advanced notice.

※ In case you want more information about the controllers and accessories, please refer to the Controller and Accessory TDB on pvi.Samsung.com site or Global Partner Portal site.

4. Installation

Tank integrated hydro unit

4. Set the FSV value by referring to the table below depending on installation environment.

Function	Details	Code	Unit	Default	Min.	Max.
Mixing valve	Use or not	4041	-	0(No)	0	2
	Target temperature difference (Heating) (TW3-TW4)	4042	°C	10	5	15
	Target temperature difference (Cooling) (TW4-TW3)	4043	°C	10	5	15
	Control factor	4044	-	2	1	5
	Interval of valve control	4045	Min.	2	1	30
	Running time (10 second unit)	4046	(x10) sec	9	6	24

※ 4041 =1 : Controlled based on the temperature difference (4042, 4043)

※ 4041 =2 : Controlled based on the temperature difference of the WL value

ex) Heating

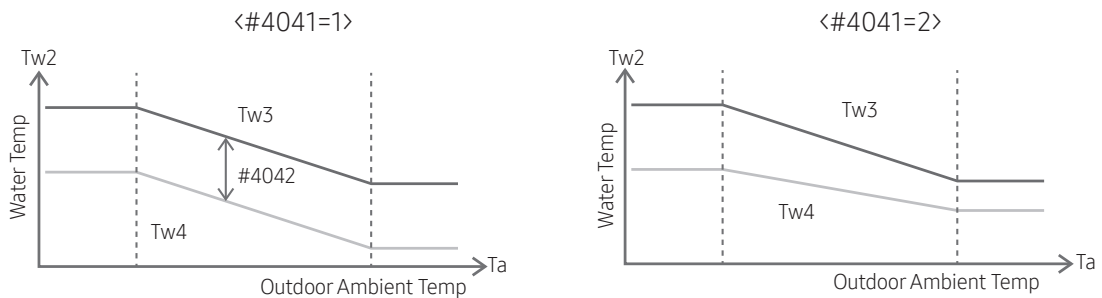

※ The mixing valve is controlled based on the FCU WL value.

※ As the #4044 value increases and the #4045 value decreases, the control speed increases. (Temperature hunting may occur if the control speed increases depending on the load.)

※ The additional pump and mixing valve should be purchased separately. TW4 sensor is included in the product accessories.

※ TW3 : Water temp. sensor 3

CAUTION

- When the thermostat control is set as 'Use', the mixing valve can be used for Zone 1 and Zone 2. (When both FSV #2091 and #2092 are set as 1/2)
- When using Zone control (FSV 4061 = 1), ignore Thermostat signal.

※ In case you want more information about the controllers and accessories, please refer to the Controller and Accessory TDB on pvi.Samsung.com site or Global Partner Portal site.

4. Installation

Tank integrated hydro unit

2-zone control using Thermostat

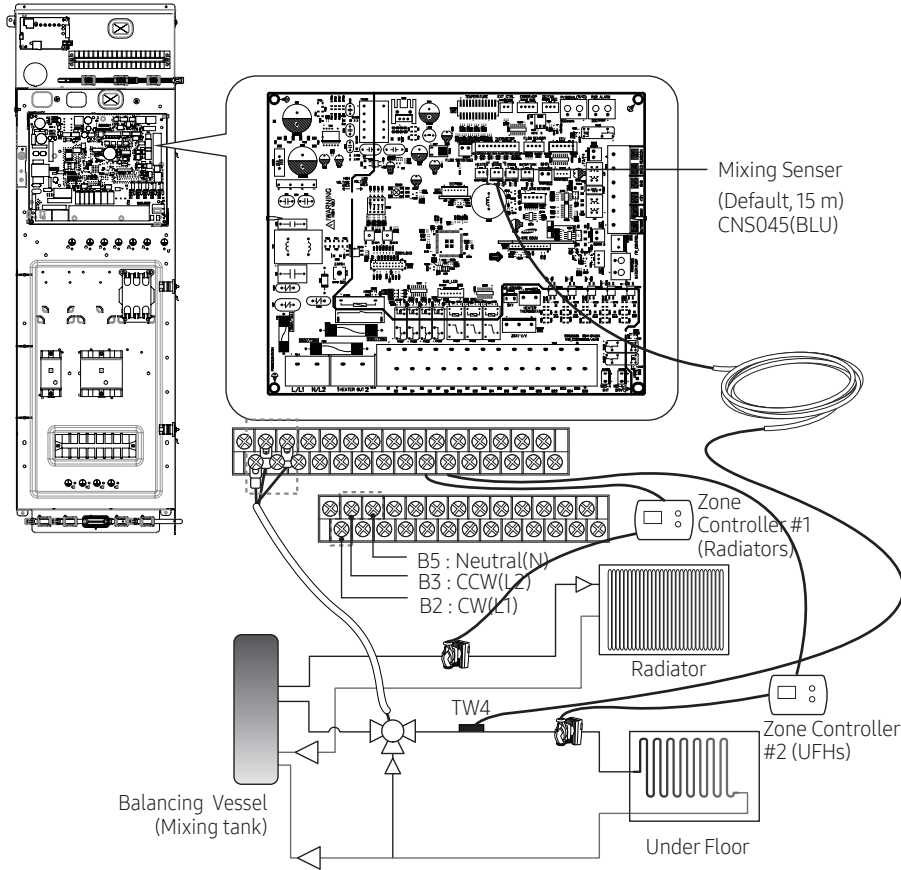

Description	No. of wires	Max. current	Thickness	Supply Scope
Mixing valve	4	22 mA	> 0.75 mm ² , H05RN-F or H07RH-F	Field supply (230 V~, Input)

1. Before the installation, hydro unit should be turned off.
2. Using the appropriate equipment to correct position of terminal block as shown on the diagram.

※ In case you want more information about the controllers and accessories, please refer to the Controller and Accessory TDB on pvi.Samsung.com site or Global Partner Portal site.

4. Installation

Tank integrated hydro unit

2-Zone Control Using Remote Controller

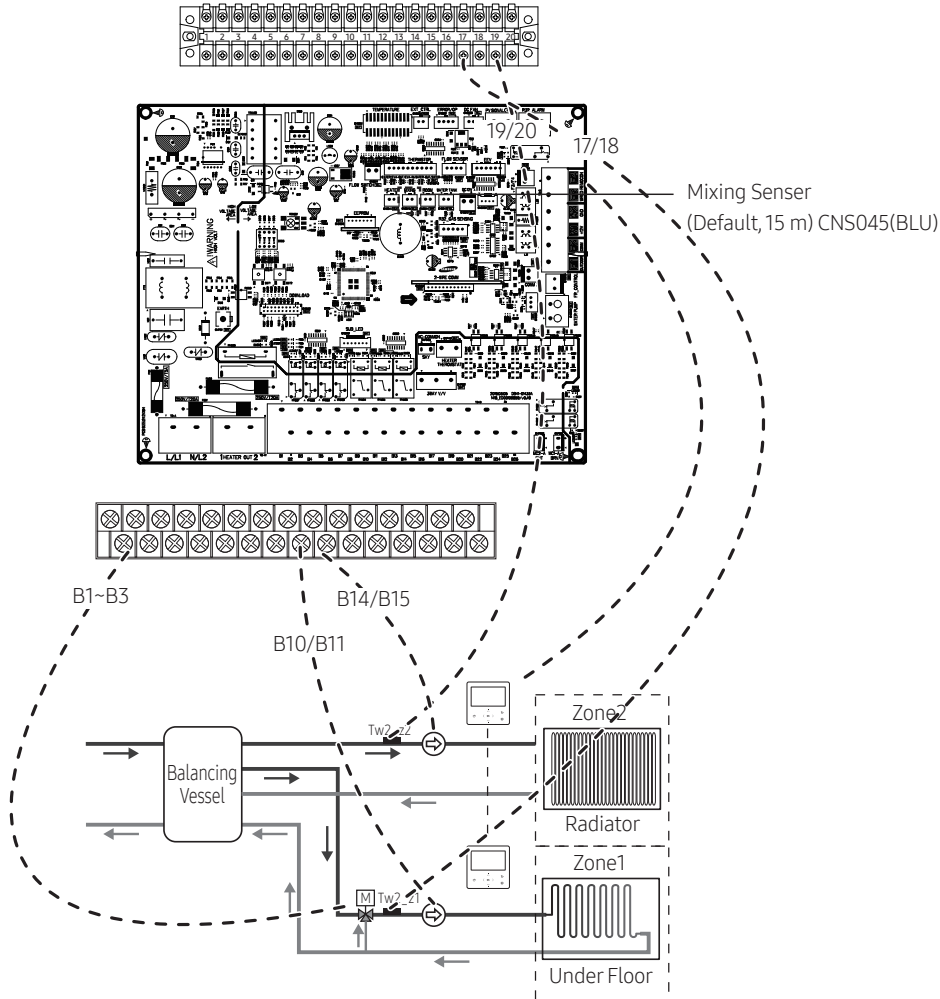

You can operate the 2-zone control using a mixing value, water-out temperature sensors, and built-in or external room temperature sensors installed in a wired remote controller.

When both zones are simultaneously Thermo on, the operation is performed based on Zone2. Therefore, set the zone that you want to have the higher set temperature to Zone2.

(The mixing valve must be installed in the zone that you want to have the lower set temperature.)

1. Install the mixing valve. (See "Installation of mixing valve.")
 2. Install the water-out temperature sensors (Tw2_z1, Tw2_z2) for all zones.
 3. Unlike the zone control with a thermostat, connect the water pump signal lines to the product.
 - Zone1 water pump connection: B10 (L1) + B11 (N)
 - Zone2 water pump connection: B14 (L1) + B15 (N)
 4. FSV 4061 = 1: Enable the 2-zone control using the wired remote controller.
- ※ If you want to operate the 2-zone control by using water-out temperatures, you have only to complete steps 1 to 4 above.
- ※ If you want to operate the 2-zone control by using room temperatures and built-in temperature sensors in wired remote controllers, you must install two wired remote controllers in each room. (If you use external room temperature sensors, you can control each room temperature with only one wired remote controller.)

※ In case you want more information about the controllers and accessories, please refer to the Controller and Accessory TDB on pvi.Samsung.com site or Global Partner Portal site.

4. Installation

Tank integrated hydro unit

Wiring work

* When you use inlet hole through the cabinet top positions for power/communication wires, please fix the wire by using mount tie of the cabinet right.

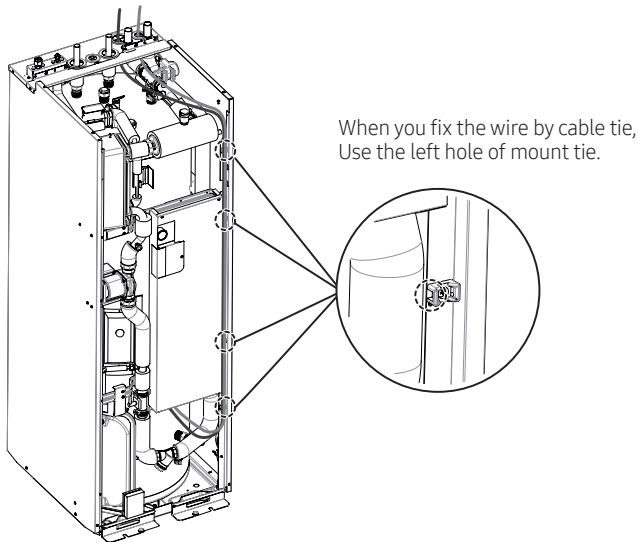

2 wires for communication cable

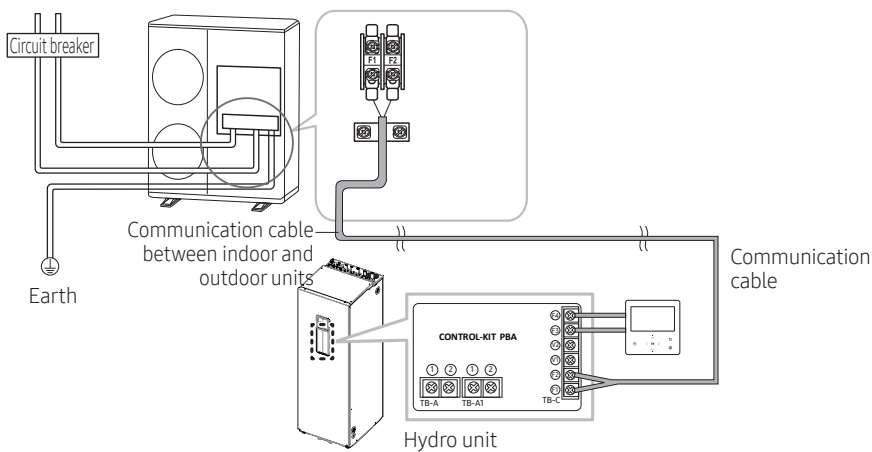

Communication cable connection

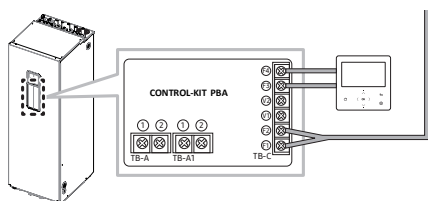

※ In case you want more information about the controllers and accessories, please refer to the Controller and Accessory TDB on pvi.Samsung.com site or Global Partner Portal site.

4. Installation

Tank integrated hydro unit

1. 1 phase product

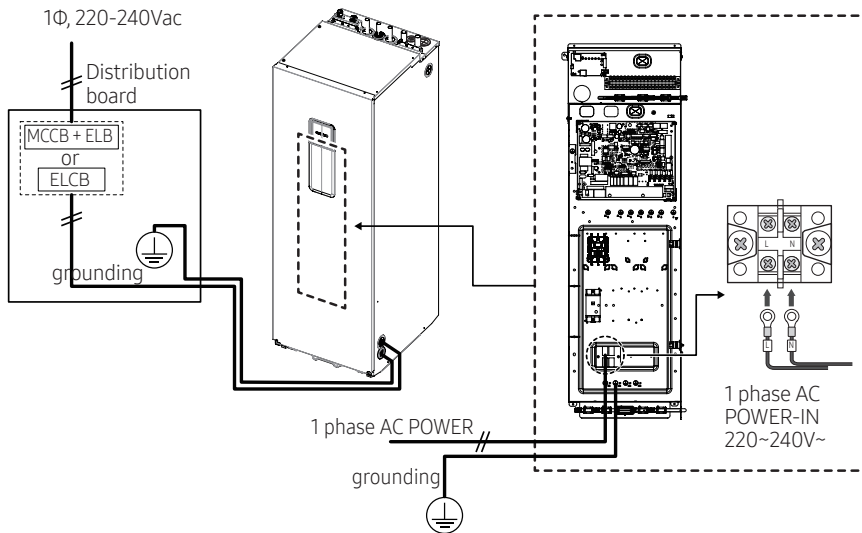

2. 3 phase product

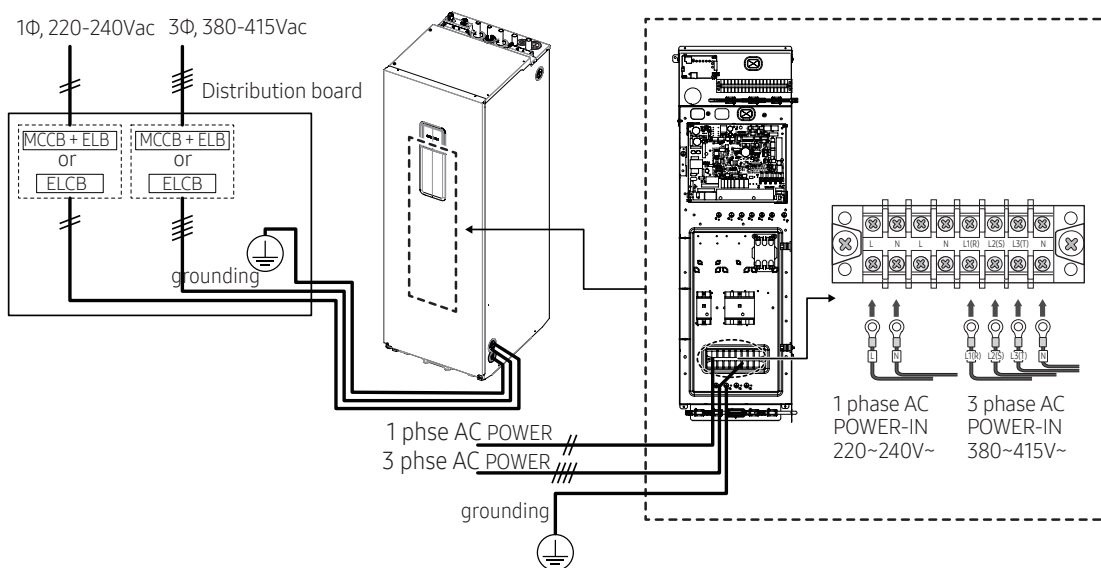

⚠ CAUTION

- If the supply cable is damaged, it must be replaced by a special cable or assembly available from the manufacturer or installer.
 - Circuit Breaker (ELCB, ELB, MCCB etc.) for outdoor and indoor units shall be installed by installers because they are not sub-parts in the units. But you don't need to install for hydro unit (Built-in ELCB).
 - It cause damage to chassis, PCB parts if the main power is not connected correctly. You should make certain that R, S, T is connected correctly before turning on the main power. (3 phase models only)
- ※ ELCB : Earth leakage circuit breaker
ELB : Earth leakage breaker
MCCB : Molded case circuit breaker

※ In case you want more information about the controllers and accessories, please refer to the Controller and Accessory TDB on pvi.Samsung.com site or Global Partner Portal site.

4. Installation

Outdoor Unit

Space requirements for outdoor unit

When installing 1 outdoor unit

(Unit : mm)

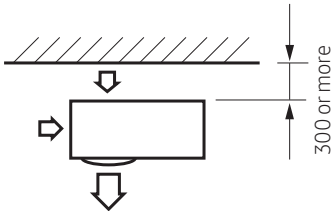

※ When the air outlet is opposite the wall

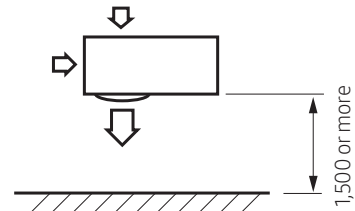

※ When the air outlet is towards the wall

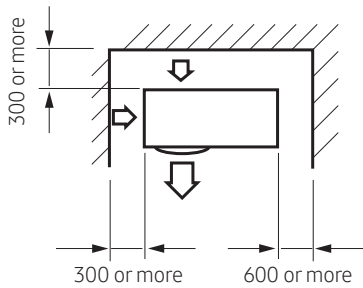

※ When 3 sides of the outdoor unit are blocked by the wall

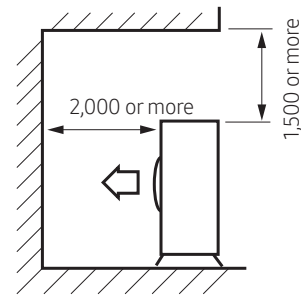

※ The upper part of the outdoor unit and the air outlet is towards the wall

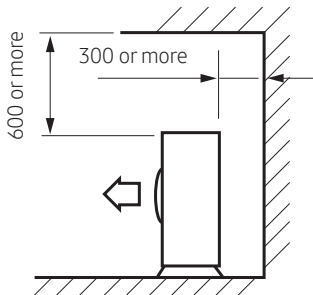

※ The upper part of the outdoor unit and the air outlet is opposite the wall

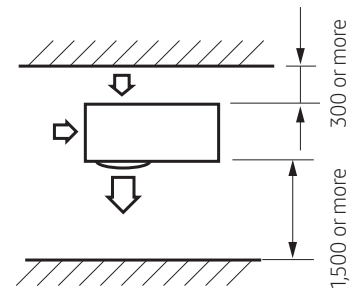

※ When front and rear side of the outdoor unit is towards the wall

※ In case you want more information about the controllers and accessories, please refer to the Controller and Accessory TDB on pvi.Samsung.com site or Global Partner Portal site.

4. Installation

Outdoor Unit

When installing more than 1 outdoor unit

(Unit : mm)

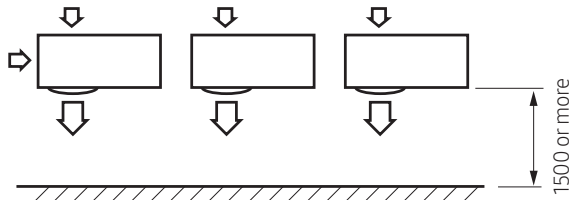

※ When the air outlet is towards the wall

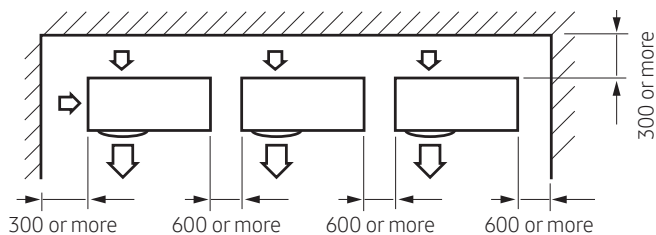

※ When 3 sides of the outdoor unit are blocked by the wall

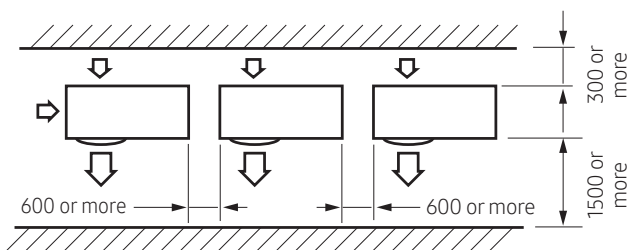

※ When front and rear side of the outdoor unit is towards the wall

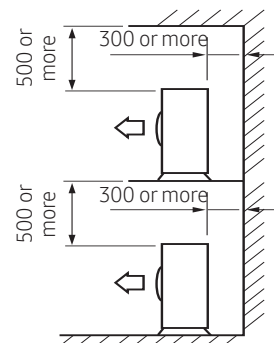

※ The upper part of the outdoor unit and the air outlet is opposite the wall

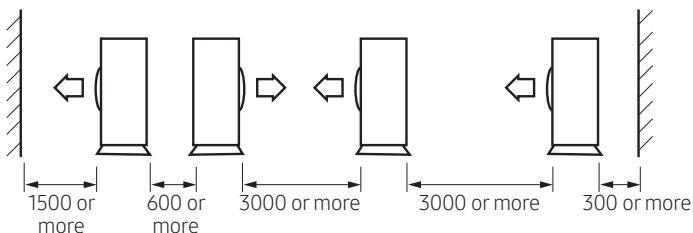

※ When front and rear side of the outdoor unit is towards the wall

⚠ CAUTION

- The units must be installed according to distances declared, in order to permit accessibility from each side, either to guarantee correct operation of maintenance or repairing products. The unit's parts must be reachable and removable completely under safety condition (for people or things).

※ In case you want more information about the controllers and accessories, please refer to the Controller and Accessory TDB on pvi.Samsung.com site or Global Partner Portal site.

4. Installation

Outdoor Unit

Outdoor unit installation

The outdoor unit must be installed on a rigid and stable base to avoid any increase in the noise level and vibration, particularly if the outdoor unit is to be installed in a location exposed to strong winds or at a height, the unit must be fixed to an appropriate support (wall or ground).

- Fix the outdoor unit with anchor bolts.

NOTE

- The mixing valve is controlled based on the FCU WL value.

CAUTION

- When tightening the anchor bolt, tighten the rubber washer to prevent the outdoor unit bolt connection part from corroding.
- Make a drain outlet around the base for outdoor unit drainage.
- If the outdoor unit is installed on the roof, you have to check the ceiling strength and waterproof the unit.

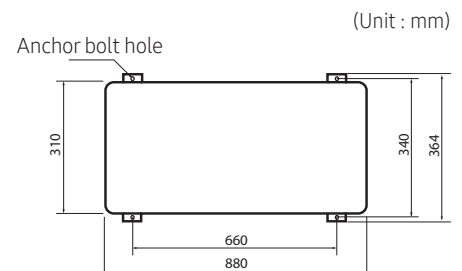
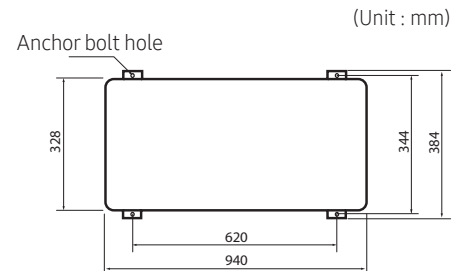

4. Installation

Outdoor Unit

Overall system configuration

Connection of the power cable (1 phase 2 wires)

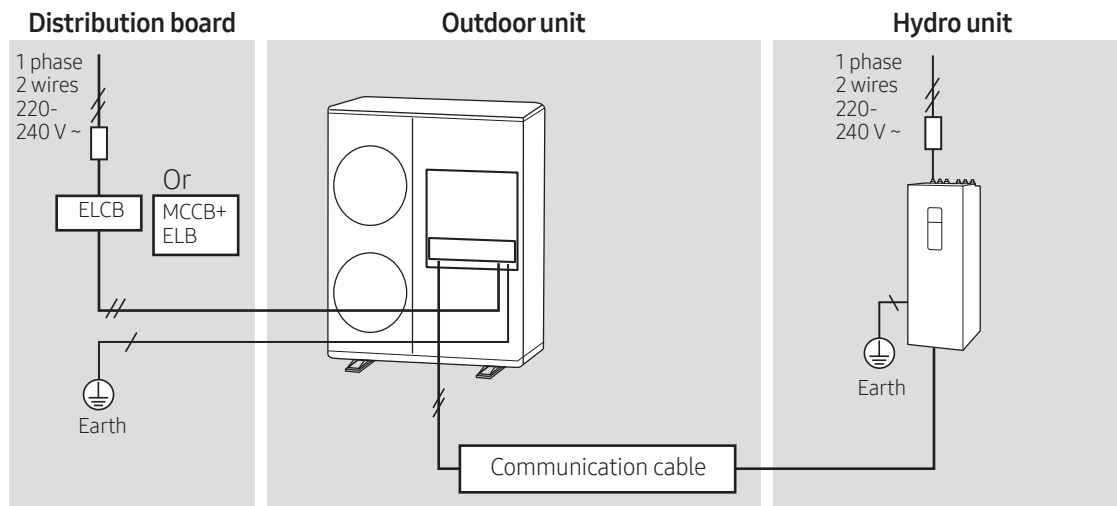

⚠ CAUTION

- Install cabinet panel near the outdoor unit for the convenience of service and emergency operation off.
- Make sure to install the circuit breaker with the over-current and electric leakage protection.

Connection of the power cable (3 phase 4 wires)

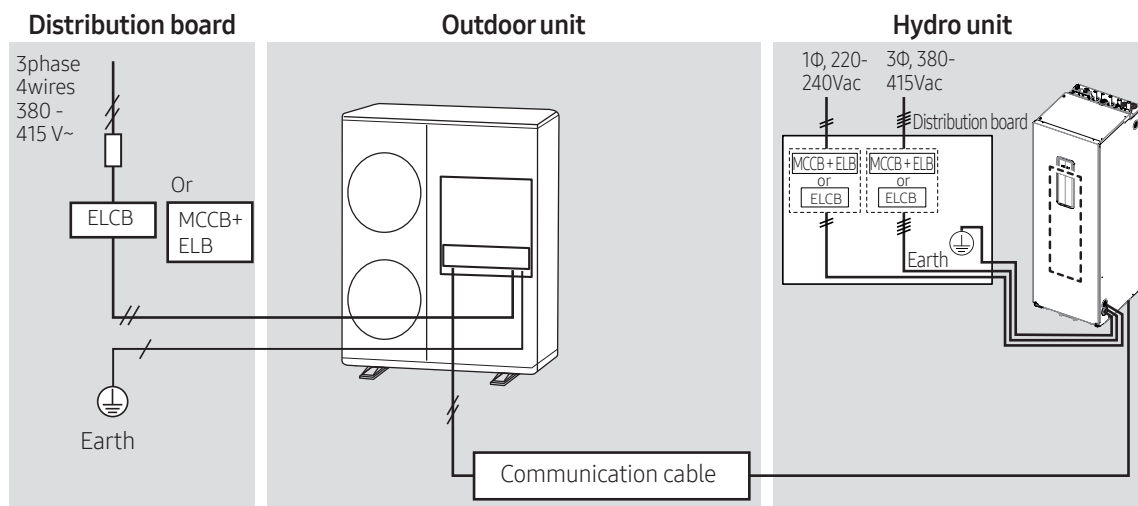

⚠ CAUTION

- Install cabinet panel near the outdoor unit for the convenience of service and emergency operation off.
- Make sure to install the circuit breaker with the over-current and electric leakage protection.

※ In case you want more information about the controllers and accessories, please refer to the Controller and Accessory TDB on pvi.Samsung.com site or Global Partner Portal site.

4. Installation

Outdoor Unit

Wiring diagram of power cable

When using ELB for 1 phase and 3 phase

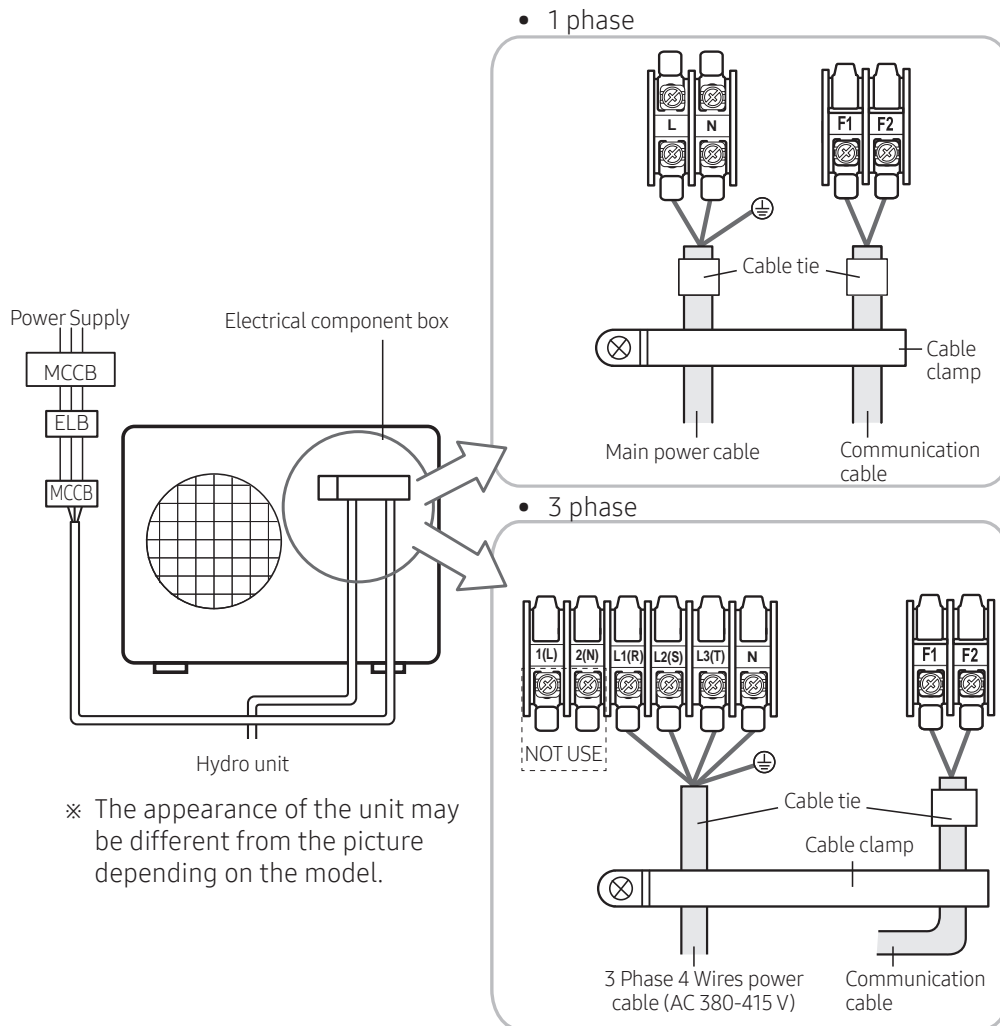

※ The appearance of the unit may be different from the picture depending on the model.

⚠ CAUTION

- You should connect the power cable into the power cable terminal and fasten it with a clamp.
- The unbalanced power must be maintained within 2 % of supply rating.
 - If the power is unbalanced greatly, it may shorten the life of the condenser. If the unbalanced power is exceeded over 4 % of supply rating, the indoor unit is protected, stopped and the error mode indicates.
- To protect the product from water and possible shock, you should keep the power cable and the connection cord of the indoor and outdoor units within ducts. (with appropriate IP rating and material selection for your application)
- Ensure that main supply connection is made through a switch that disconnects all poles, with contact gap of a least 3 mm.
- Devices disconnected from the power supply should be completely disconnected in the condition of overvoltage category.
- Keep distances of 50 mm or more between power cable and communication cable.

※ In case you want more information about the controllers and accessories, please refer to the Controller and Accessory TDB on pvi.Samsung.com site or Global Partner Portal site.

4. Installation

Outdoor Unit

1 phase 2 wires

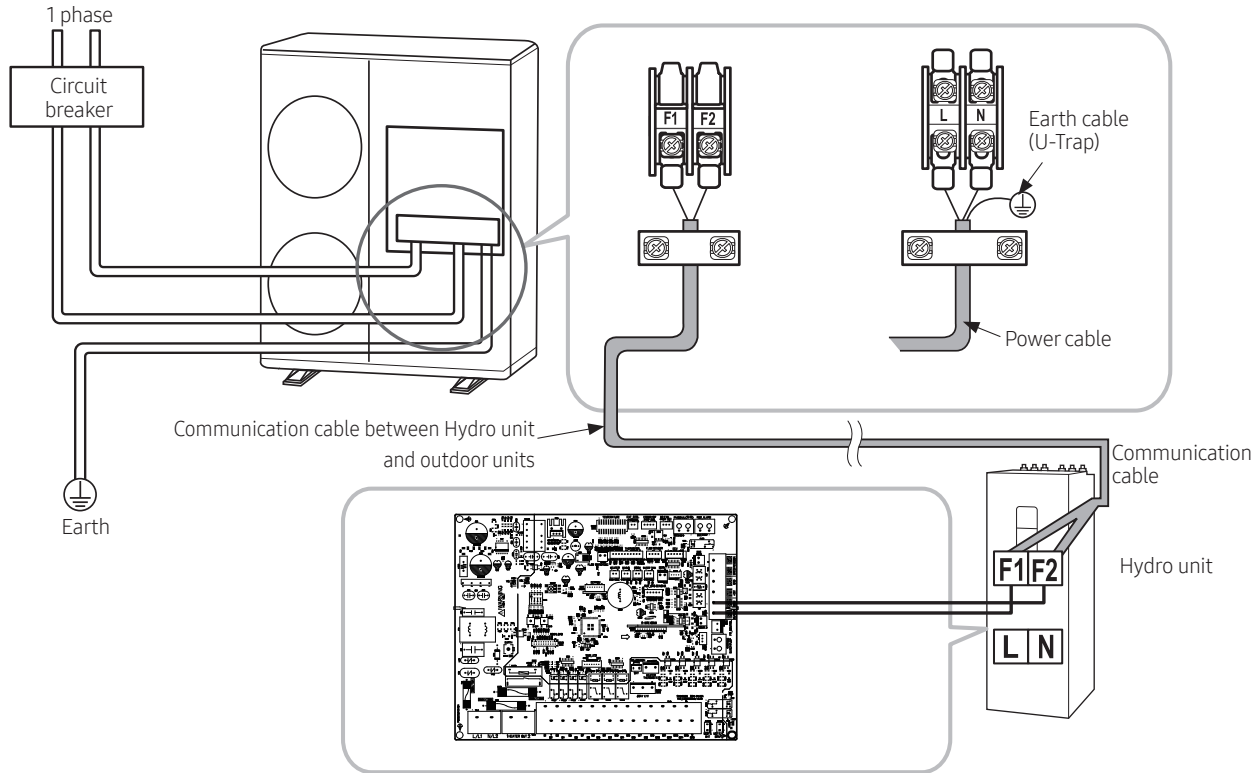

⚠ CAUTION

- When removing the outer cover of the power cable, use the appropriate tools to prevent damaging the inner cover.
- Make sure to place the outer cover of the power cable and the communication cable, at least 20 mm into the electrical parts.
- Communication wiring should be done separately from the power cable and other communication cables.

※ In case you want more information about the controllers and accessories, please refer to the Controller and Accessory TDB on pvi.Samsung.com site or Global Partner Portal site.

4. Installation

Outdoor Unit

3 phase 4 wires

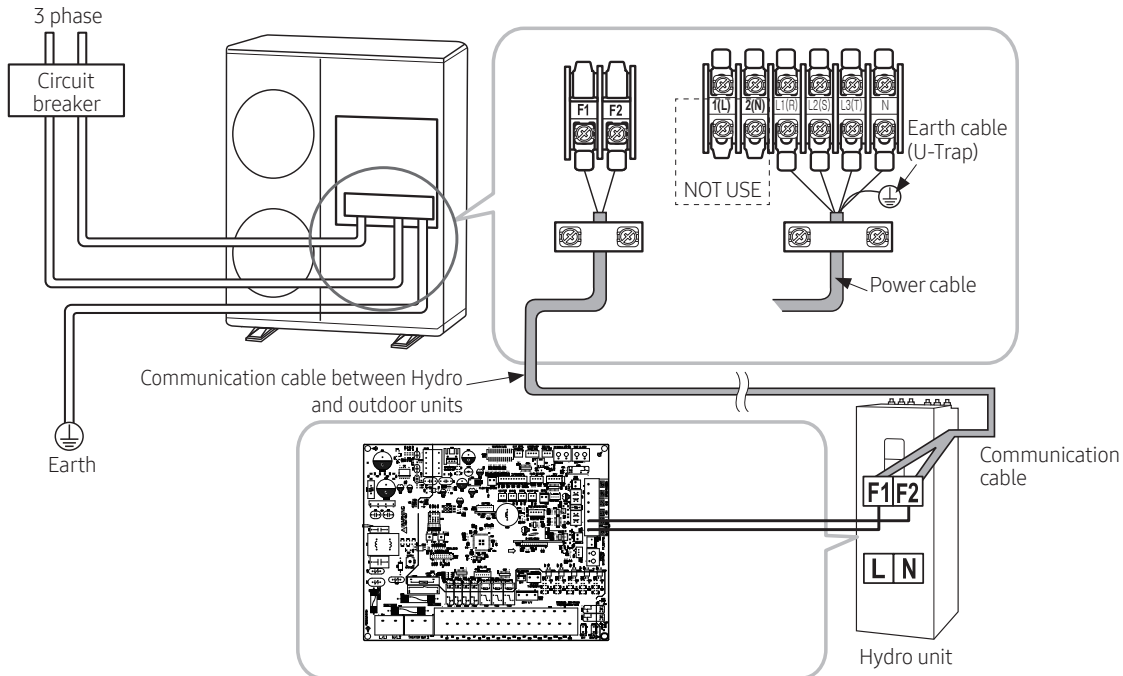

⚠ CAUTION

- When removing the outer cover of the power cable, use the appropriate tools to prevent damaging the inner cover.
- Make sure to place the outer cover of the power cable and the communication cable, at least 20 mm into the electrical parts.
- Communication wiring should be done separately from the power cable and other communication cables.

※ In case you want more information about the controllers and accessories, please refer to the Controller and Accessory TDB on pvi.Samsung.com site or Global Partner Portal site.

2021.11
Ver.2.1

Samsung Electronics Co., LTD.

Head Office (Suwon Korea) 129, Samsung-Ro, Yeongtong-Gu, Suwon City, Gyeonggi-Do, Korea 16677
Website : www.samsung.com, <https://partnerhub.samsung.com> Email : airconditioner@samsung.com
Images and data in this book may subject to change without prior notice.