

Service Manual

Air Conditioner

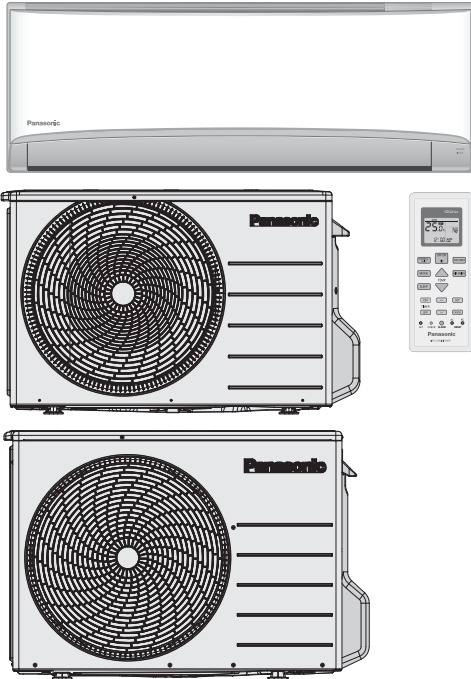

Indoor Unit
 CS-TE20TKEW
 CS-TE25TKEW
 CS-TE35TKEW
 CS-TE42TKEW

Outdoor Unit
 CU-TE20TKE
 CU-TE25TKE
 CU-TE35TKE
 CU-TE42TKE

Destination
 Europe
 Turkey

Please file and use this manual together with the service manual for Model No. CU-2E12SBE, CU-2E15SBE, CU-2E18SBE, CU-3E18PBE, CU-3E23SBE, CU-4E23PBE, CU-4E27PBE, CU-5E34PBE, CU-2RE15SBE, CU-2RE18SBE, CU-3RE18SBE, Order No. PAPAMY1601016CE, PAPAMY1601015CE, PAPAMY1301048CE, PAPAMY1303046CE.

WARNING

This service information is designed for experienced repair technicians only and is not designed for use by the general public. It does not contain warnings or cautions to advise non-technical individuals of potential dangers in attempting to service a product. Products powered by electricity should be serviced or repaired only by experienced professional technicians. Any attempt to service or repair the products dealt with in this service information by anyone else could result in serious injury or death.

IMPORTANT SAFETY NOTICE

There are special components used in this equipment which are important for safety. These parts are marked by  in the Schematic Diagrams, Circuit Board Diagrams, Exploded Views and Replacement Parts List. It is essential that these critical parts should be replaced with manufacturer's specified parts to prevent shock, fire or other hazards. Do not modify the original design without permission of manufacturer.



PRECAUTION OF LOW TEMPERATURE



In order to avoid frostbite, be assured of no refrigerant leakage during the installation or repairing of refrigerant circuit.

TABLE OF CONTENTS

	PAGE		PAGE
1. Safety Precautions	3	14. Protection Control	57
2. Specifications	5	14.1 Protection Control for All Operations	57
3. Features	14	14.2 Protection Control for Cooling & Soft Dry Operation	59
4. Location of Controls and Components	15	14.3 Protection Control for Heating Operation ...	60
4.1 Indoor Unit	15	15. Servicing Mode	62
4.2 Outdoor Unit	15	15.1 Auto OFF/ON Button	62
4.3 Remote Control	15	15.2 Heat Only Operation	63
5. Dimensions	16	15.3 Remote Control Button	64
5.1 Indoor Unit	16	16. Troubleshooting Guide	67
5.2 Outdoor Unit	17	16.1 Refrigeration Cycle System	67
6. Refrigeration Cycle Diagram	18	16.2 Breakdown Self Diagnosis Function	69
7. Block Diagram	19	16.3 Error Codes Table	70
7.1 Indoor Unit	19	16.4 Self-diagnosis Method	72
7.2 Outdoor Unit	20	17. Disassembly and Assembly Instructions ...	100
8. Wiring Connection Diagram	23	17.1 Indoor Electronic Controllers, Cross Flow Fan and Indoor Fan Motor Removal Procedures	100
8.1 Indoor Unit	23	17.2 Outdoor Electronic Controller Removal Procedure	104
8.2 Outdoor Unit	24	18. Technical Data	106
9. Electronic Circuit Diagram	27	18.1 Cool Mode Performance Data	106
9.1 Indoor Unit	27	18.2 Heat Mode Performance Data	108
9.2 Outdoor Unit	28	19. Service Data	109
10. Printed Circuit Board	31	19.1 Cool Mode Outdoor Air Temperature Characteristic	109
10.1 Indoor Unit	31	19.2 Heat Mode Outdoor Air Temperature Characteristic	113
10.2 Outdoor Unit	33	19.3 Piping Length Correction Factor	117
11. Installation Instruction	36	20. Exploded View and Replacement Parts List	118
11.1 Select the Best Location	36	20.1 Indoor Unit	118
11.2 Indoor Unit	37	20.2 Outdoor Unit	122
11.3 Outdoor Unit	42		
12. Operation Control	48		
12.1 Basic Function	48		
12.2 Indoor Fan Motor Operation	49		
12.3 Outdoor Fan Motor Operation	50		
12.4 Airflow Direction	51		
12.5 Timer Control	52		
12.6 Sleep Mode Operation	53		
12.7 Auto Restart Control	53		
12.8 Indication Panel	53		
12.9 Quiet Operation (Cooling Mode/Cooling Area of Dry Mode)	53		
12.10 Quiet Operation (Heating)	54		
12.11 Powerful Mode Operation	54		
13. Operation Control (For Multi Split Connection)	55		
13.1 Cooling operation	55		
13.2 Soft Dry Operation	55		
13.3 Heating Operation	55		
13.4 Automatic Operation	56		
13.5 Indoor Fan Motor Operation	56		
13.6 Powerful Mode Operation	56		
13.7 Auto Restart Control	56		
13.8 Indication Panel	56		

1. Safety Precautions







- Read the following “SAFETY PRECAUTIONS” carefully before perform any servicing.
- Electrical work must be installed or serviced by a licensed electrician. Be sure to use the correct rating of the power plug and main circuit for the model installed.
- The caution items stated here must be followed because these important contents are related to safety. The meaning of each indication used is as below. Incorrect installation or servicing due to ignoring of the instruction will cause harm or damage, and the seriousness is classified by the following indications.

 WARNING	This indication shows the possibility of causing death or serious injury.
 CAUTION	This indication shows the possibility of causing injury or damage to properties.

- The items to be followed are classified by the symbols:

	This symbol denotes item that is PROHIBITED from doing.
---	---







- Carry out test run to confirm that no abnormality occurs after the servicing. Then, explain to user the operation, care and maintenance as stated in instructions. Please remind the customer to keep the operating instructions for future reference.

 WARNING	
1.	Do not modify the machine, part, material during repairing service.
2.	If wiring unit is supplied as repairing part, do not repair or connect the wire even only partial wire break. Exchange the whole wiring unit.
3.	Do not wrench the fasten terminal. Pull it out or insert it straightly.
4.	Engage dealer or specialist for installation and servicing. If installation of servicing done by the user is defective, it will cause water leakage, electrical shock or fire.
5.	Install according to this installation instructions strictly. If installation is defective, it will cause water leakage, electric shock or fire.
6.	Use the attached accessories parts and specified parts for installation and servicing. Otherwise, it will cause the set to fall, water leakage, fire or electrical shock.
7.	Install at a strong and firm location which is able to withstand the set's weight. If the strength is not enough or installation is not properly done, the set will drop and cause injury.
8.	For electrical work, follow the local national wiring standard, regulation and the installation instruction. An independent circuit and single outlet must be used. If electrical circuit capacity is not enough or defect found in electrical work, it will cause electrical shock or fire.
9.	This equipment is strongly recommended to install with Earth Leakage Circuit Breaker (ELCB) or Residual Current Device (RCD). Otherwise, it may cause electrical shock and fire in case equipment breakdown or insulation breakdown.
10.	Do not use joint cable for indoor / outdoor connection cable. Use the specified Indoor/Outdoor connection cable, refer to installation instruction CONNECT THE CABLE TO THE INDOOR UNIT and connect tightly for indoor / outdoor connection. Clamp the cable so that no external force will be acted on the terminal. If connecting or fixing is not perfect, it will cause heat up or fire at the connection.
11.	Wire routing must be properly arranged so that control board cover is fixed properly. If control board cover is not fixed perfectly, it will cause heat-up or fire at the connection point of terminal, fire or electrical shock.
12.	When install or relocate air conditioner, do not let any substance other than the specified refrigerant, eg. air etc. mix into refrigeration cycle (piping). (Mixing of air etc. will cause abnormal high pressure in refrigeration cycle and result in explosion, injury etc.).
13.	Do not install outdoor unit near handrail of veranda. When installing air-conditioner unit at veranda of high rise building, child may climb up to outdoor unit and cross over the handrail and causing accident.
14.	This equipment must be properly earthed. Earth line must not be connected to gas pipe, water pipe, earth of lightning rod and telephone. Otherwise, it may cause electric shock in case equipment breakdown or insulation breakdown. 
15.	Keep away from small children, the thin film may cling to nose and mouth and prevent breathing. 
16.	Do not use unspecified cord, modified cord, joint cord or extension cord for power supply cord. Do not share the single outlet with other electrical appliances. Poor contact, poor insulation or over current will cause electrical shock or fire. 
17.	Tighten the flare nut with torque wrench according to specified method. If the flare nut is over-tightened, after a long period, the flare may break and cause refrigerant gas leakage. 
18.	<ul style="list-style-type: none"> • For R410A model, use piping, flare nut and tools which is specified for R410A refrigerant. Using of existing (R22) piping, flare nut and tools may cause abnormally high pressure in the refrigerant cycle (piping), and possibly result in explosion and injury.  • Thickness of copper pipes used with R410A must be more than 0.8 mm. Never use copper pipes thinner than 0.8 mm. • It is desirable that the amount of residual oil less than 40 mg/10 m.
19.	During installation, install the refrigerant piping properly before run the compressor. (Operation of compressor without fixing refrigeration piping and valves at opened condition will caused suck-in of air, abnormal high pressure in refrigeration cycle and result in explosion, injury etc).

 **WARNING**

20.	During pump down operation, stop the compressor before remove the refrigeration piping. (Removal of compressor while compressor is operating and valves are opened will cause suck-in of air, abnormal high pressure in refrigeration cycle and result in explosion, injury etc.)	
21.	After completion of installation or service, confirm there is no leakage or refrigerant gas. It may generate toxic gas when the refrigerant contacts with fire.	
22.	Ventilate if there is refrigerant gas leakage during operation. It may cause toxic gas when refrigerant contacts with fire.	
23.	Do not insert your fingers or other objects into the unit, high speed rotating fan may cause injury.	
24.	Must not use other parts except original parts described in catalog and manual.	
25.	Using of refrigerant other than the specified type may cause product damage, burst and injury etc.	

 **CAUTION**

1.	Do not install the unit at place where leakage of flammable gas may occur. In case gas leaks and accumulates at surrounding of the unit, it may cause fire.	
2.	Carry out drainage piping as mentioned in installation instructions. If drainage is not perfect, water may enter the room and damage the furniture.	
3.	Tighten the flare nut with torque wrench according to specified method. If the flare nut is over-tightened, after a long period, the flare may break and cause refrigerant gas leakage.	
4.	Do not touch outdoor unit air inlet and aluminium fin. It may cause injury.	
5.	Select an installation location which is easy for maintenance.	
6.	Pb free solder has a higher melting point than standard solder; typically the melting point is 50°F – 70°F (30°C – 40°C) higher. Please use a high temperature solder iron. In case of the soldering iron with temperature control, please set it to 700 ± 20°F (370 ± 10°C). Pb free solder will tend to splash when heated too high (about 1100°F / 600°C).	
7.	Power supply connection to the room air conditioner. Use power supply cord 3 × 1.5 mm ² (3/4 ~ 1.75HP) type designation 60245 IEC 57 or heavier cord. Connect the power supply cord of the air conditioner to the mains using one of the following method. Power supply point should be in easily accessible place for power disconnection in case of emergency. In some countries, permanent connection of this air conditioner to the power supply is prohibited. 1) Power supply connection to the receptacle using power plug. Use an approved 15/16A (3/4 ~ 1.75HP) power plug with earth pin for the connection to the socket. 2) Power supply connection to a circuit breaker for the permanent connection. Use an approved 16A (3/4 ~ 1.75HP) circuit breaker for the permanent connection. It must be a double pole switch with a minimum 3.0 mm contact gap.	
8.	Do not release refrigerant during piping work for installation, servicing, reinstallation and during repairing a refrigerant parts. Take care of the liquid refrigerant, it may cause frostbite.	
9.	Installation or servicing work: It may need two people to carry out the installation or servicing work.	
10.	Do not install this appliance in a laundry room or other location where water may drip from the ceiling, etc.	
11.	Do not sit or step on the unit, you may fall down accidentally.	
12.	Do not touch the sharp aluminium fins or edges of metal parts. If you are required to handle sharp parts during installation or servicing, please wear hand glove. Sharp parts may cause injury.	

2. Specifications

Model		Indoor	CS-TE20TKEW			CS-TE25TKEW				
		Outdoor	CU-TE20TKE			CU-TE25TKE				
Performance Test Condition			EUROVENT			EUROVENT				
Power Supply		Phase, Hz	Single, 50			Single, 50				
		V	230			230				
			Min.	Mid.	Max.	Min.	Mid.	Max.		
Cooling	Capacity		kW	0.75	2.00	2.40	0.85	2.50	3.00	
			BTU/h	2560	6820	8180	2900	8530	10200	
			Kcal/h	650	1720	2060	730	2150	2580	
	Running Current		A	–	2.40	–	–	3.00	–	
	Input Power		W	250	530	640	250	670	910	
	Annual Consumption		kWh	–	265	–	–	335	–	
	EER		W/W	3.00	3.77	3.75	3.40	3.73	3.30	
			BTU/hW	10.24	12.87	12.78	11.60	12.73	11.21	
			Kcal/hW	2.60	3.25	3.22	2.92	3.21	2.84	
	ErP	Pdesign		kW	2.0			2.5		
		SEER		(W/W)	6.1			6.1		
		Annual Consumption		kWh	115			143		
		Class			A++			A++		
	Power Factor		%	–	96	–	–	97	–	
	Indoor Noise (H / L / QLo)		dB-A	37 / 25 / 20			40 / 26 / 20			
			Power Level dB	53 / 41 / 36			56 / 42 / 36			
	Outdoor Noise (H / L / QLo)		dB-A	46 / – / –			47 / – / –			
			Power Level dB	61 / – / –			62 / – / –			
	Heating	Capacity		kW	0.70	2.70	3.60	0.80	3.30	4.10
				BTU/h	2390	9210	12300	2730	11300	14000
Kcal/h				600	2320	3100	690	2840	3530	
Running Current		A	–	3.05	–	–	3.60	–		
Input Power		W	185	680	1.05k	195	810	1.15k		
COP		W/W	3.78	3.97	3.43	4.10	4.07	3.57		
		BTU/hW	12.92	13.54	11.71	14.00	13.95	12.17		
		Kcal/hW	3.24	3.41	2.95	3.54	3.51	3.07		
ErP		Pdesign		kW	1.9			2.4		
		Tbivalent		°C	-10			-10		
		SCOP		(W/W)	4.0			4.1		
		Annual Consumption		kWh	665			820		
		Class			A+			A+		
Power Factor		%	–	97	–	–	98	–		
Indoor Noise (H / L / QLo)		dB-A	38 / 26 / 22			40 / 27 / 22				
		Power Level dB	54 / 42 / 38			56 / 43 / 38				
Outdoor Noise (H / L / QLo)		dB-A	47 / – / –			48 / – / –				
		Power Level dB	62 / – / –			63 / – / –				
Low Temp. : Capacity (kW) / I.Power (W) / COP			2.61 / 930 / 2.81			2.97 / 1.02k / 2.91				
Extr Low Temp. : Capacity (kW) / I.Power (W) / COP			2.14 / 870 / 2.46			2.70 / 1.07k / 2.52				
Max Current (A) / Max Input Power (W)			4.7 / 1.05k			5.1 / 1.15k				
Starting Current (A)			3.05			3.60				

Model			Indoor	CS-TE20TKEW	CS-TE25TKEW	
			Outdoor	CU-TE20TKE	CU-TE25TKE	
Compressor	Type			Hermetic Motor (Rotary)	Hermetic Motor (Rotary)	
	Motor Type			Brushless (6 poles)	Brushless (6 poles)	
	Output Power		W	500	500	
Indoor Fan	Type			Cross-Flow Fan	Cross-Flow Fan	
	Material			ASG20K1	ASG20K1	
	Motor Type			DC / Transistor (8-poles)	DC / Transistor (8-poles)	
	Input Power		W	47.3	47.3	
	Output Power		W	30	30	
	Speed	QLo	Cool	rpm	630	630
			Heat	rpm	730	730
		Lo	Cool	rpm	770	800
			Heat	rpm	820	850
		Me	Cool	rpm	940	1010
			Heat	rpm	1020	1070
		Hi	Cool	rpm	1120	1220
			Heat	rpm	1220	1290
	SHi	Cool	rpm	1170	1270	
Heat		rpm	1270	1340		
Outdoor Fan	Type			Propeller Fan	Propeller Fan	
	Material			PP	PP	
	Motor Type			DC (8-poles)	DC (8-poles)	
	Input Power		W	-	-	
	Output Power		W	40	40	
	Speed	Hi	Cool	rpm	840	830
Heat			rpm	800	800	
Moisture Removal			L/h (Pt/h)	1.3 (2.7)	1.5 (3.2)	
Indoor Airflow	QLo	Cool	m ³ /min (ft ³ /min)	5.27 (186)	5.27 (186)	
		Heat	m ³ /min (ft ³ /min)	6.23 (220)	6.23 (220)	
	Lo	Cool	m ³ /min (ft ³ /min)	6.62 (234)	6.90 (244)	
		Heat	m ³ /min (ft ³ /min)	7.10 (251)	7.38 (261)	
	Me	Cool	m ³ /min (ft ³ /min)	8.25 (291)	8.92 (315)	
		Heat	m ³ /min (ft ³ /min)	9.02 (319)	9.50 (335)	
	Hi	Cool	m ³ /min (ft ³ /min)	10.00 (350)	10.90 (385)	
		Heat	m ³ /min (ft ³ /min)	10.90 (385)	11.60 (410)	
SHi	Cool	m ³ /min (ft ³ /min)	10.46 (369)	11.42 (403)		
	Heat	m ³ /min (ft ³ /min)	11.42 (403)	12.09 (427)		
Outdoor Airflow	Hi	Cool	m ³ /min (ft ³ /min)	31.20 (1100)	30.00 (1060)	
		Heat	m ³ /min (ft ³ /min)	29.70 (1050)	28.90 (1020)	
Refrigeration Cycle	Control Device			Expansion Valve	Expansion Valve	
	Refrigerant Oil		cm ³	FV50S (250)	FV50S (250)	
	Refrigerant Type		g (oz)	R410A, 660 (23.3)	R410A, 770 (27.2)	
F-Gas	GWP			2088	2088	
	CO2eq (ton) (Precharged Amount / Maximum Charged Amount)			1.378 / 1.613	1.608 / 1.843	
Dimension	Height (I/D / O/D)		mm (inch)	290 (11-7/16) / 542 (21-11/32)	290 (11-7/16) / 542 (21-11/32)	
	Width (I/D / O/D)		mm (inch)	799 (31-15/32) / 780 (30-23/32)	799 (31-15/32) / 780 (30-23/32)	
	Depth (I/D / O/D)		mm (inch)	197 (7-25/32) / 289 (11-13/32)	197 (7-25/32) / 289 (11-13/32)	
Weight	Net (I/D / O/D)		kg (lb)	8 (18) / 26 (57)	8 (18) / 27 (60)	

Model		Indoor	CS-TE20TKEW		CS-TE25TKEW	
		Outdoor	CU-TE20TKE		CU-TE25TKE	
Piping	Pipe Diameter (Liquid / Gas)	mm (inch)	6.35 (1/4) / 9.52 (3/8)		6.35 (1/4) / 9.52 (3/8)	
	Standard length	m (ft)	5.0 (16.4)		5.0 (16.4)	
	Length range (min – max)	m (ft)	3 (9.8) ~ 15 (49.2)		3 (9.8) ~ 15 (49.2)	
	I/D & O/D Height different	m (ft)	15.0 (49.2)		15.0 (49.2)	
	Additional Gas Amount	g/m (oz/ft)	15 (0.2)		15 (0.2)	
	Length for Additional Gas	m (ft)	7.5 (24.6)		7.5 (24.6)	
Drain Hose	Inner Diameter	mm	16.7		16.7	
	Length	mm	650		650	
Indoor Heat Exchanger	Fin Material		Aluminium (Pre Coat)		Aluminium (Pre Coat)	
	Fin Type		Slit Fin		Slit Fin	
	Row × Stage × FPI		2 × 15 × 17		2 × 15 × 17	
	Size (W × H × L)	mm	610 × 315 × 25.4		610 × 315 × 25.4	
Outdoor Heat Exchanger	Fin Material		Aluminium		Aluminium	
	Fin Type		Corrugated Fin (Pre Coat)		Corrugated Fin	
	Row × Stage × FPI		1 × 24 × 17		1 × 24:12 × 17	
	Size (W × H × L)	mm	36.4 × 504 × 710		36.4 × 504 × 713:684	
Air Filter	Material		Polypropelene		Polypropelene	
	Type		One-touch		One-touch	
Power Supply			Outdoor		Outdoor	
Power Supply Cord		A	Nil		Nil	
Thermostat			Electronic Contol		Electronic Contol	
Protection Device			Electronic Contol		Electronic Contol	
			Dry Bulb	Wet Bulb	Dry Bulb	Wet Bulb
Indoor Operation Range	Cooling	Maximum °C	32	23	32	23
		Minimum °C	16	11	16	11
	Heating	Maximum °C	30	–	30	–
		Minimum °C	16	–	16	–
Outdoor Operation Range	Cooling	Maximum °C	43	26	43	26
		Minimum °C	-10	–	-10	–
	Heating	Maximum °C	24	18	24	18
		Minimum °C	-15	-16	-15	-16

1. Cooling capacities are based on indoor temperature of 27°C Dry Bulb (80.6°F Dry Bulb), 19.0°C Wet Bulb (66.2°F Wet Bulb) and outdoor air temperature of 35°C DRY BULB (95°F Dry Bulb), 24°C Wet Bulb (75.2°F Wet Bulb)
2. Heating capacities are based on indoor temperature of 20°C Dry Bulb (68°F Dry Bulb) and outdoor air temperature of 7°C Dry Bulb (44.6°F Dry Bulb), 6°C Wet Bulb (42.8°F Wet Bulb)
3. Heating low temperature capacity, Input Power and COP measured at 230 V, indoor temperature 20°C, outdoor 2/1°C
4. Heating extreme low temperature capacity, Input Power and COP measured at 230 V, indoor temperature 20°C, outdoor -7/-8°C
5. Standby power consumption ≤10.0w (when switched OFF by remote control, except under self protection control).
6. Specifications are subjected to change without prior notice for further improvement.

Model		Indoor	CS-TE35TKEW			CS-TE42TKEW				
		Outdoor	CU-TE35TKE			CU-TE42TKE				
Performance Test Condition			EUROVENT			EUROVENT				
Power Supply		Phase, Hz	Single, 50			Single, 50				
		V	230			230				
			Min.	Mid.	Max.	Min.	Mid.	Max.		
Cooling	Capacity		kW	0.85	3.50	3.90	0.85	4.20	4.60	
			BTU/h	2900	11900	13300	2900	14300	15700	
			Kcal/h	730	3010	3350	730	3610	3960	
	Running Current		A	–	4.55	–	–	5.65	–	
	Input Power		W	255	1.02k	1.21k	265	1.28k	1.67k	
	Annual Consumption		kWh	–	510	–	–	640	–	
	EER		W/W	3.33	3.43	3.22	3.21	3.28	2.75	
			BTU/hW	11.37	11.67	10.99	10.94	11.17	9.40	
			Kcal/hW	2.86	2.95	2.77	2.75	2.82	2.37	
	ErP	Pdesign	kW	3.5			4.2			
		SEER	(W/W)	6.1			5.6			
		Annual Consumption	kWh	201			263			
		Class		A++			A+			
	Power Factor		%	–	97	–	–	98	–	
	Indoor Noise (H / L / QLo)		dB-A	42 / 30 / 20			44 / 31 / 29			
			Power Level dB	58 / 46 / 36			60 / 47 / 45			
	Outdoor Noise (H / L / QLo)		dB-A	48 / – / –			49 / – / –			
			Power Level dB	63 / – / –			64 / – / –			
	Heating	Capacity		kW	0.80	4.00	5.10	0.80	5.00	6.80
				BTU/h	2730	13600	17400	2730	17100	23200
Kcal/h				690	3440	4390	690	4300	5850	
Running Current		A	–	4.70	–	–	6.05	–		
Input Power		W	200	1.07k	1.44k	200	1.37k	2.07k		
COP		W/W	4.00	3.74	3.54	4.00	3.65	3.29		
		BTU/hW	13.65	12.71	12.08	13.65	12.48	11.21		
		Kcal/hW	3.45	3.21	3.05	3.45	3.14	2.83		
ErP		Pdesign	kW	2.8			3.6			
		Tbivalent	°C	-10			-10			
		SCOP	(W/W)	4.1			3.8			
		Annual Consumption	kWh	956			1326			
		Class		A+			A			
Power Factor		%	–	99	–	–	98	–		
Indoor Noise (H / L / QLo)		dB-A	42 / 33 / 22			44 / 35 / 28				
		Power Level dB	58 / 49 / 38			60 / 51 / 44				
Outdoor Noise (H / L / QLo)		dB-A	50 / – / –			51 / – / –				
		Power Level dB	65 / – / –			66 / – / –				
Low Temp. : Capacity (kW) / I.Power (W) / COP			3.70 / 1.27k / 2.91			4.93 / 1.83k / 2.69				
Extr Low Temp. : Capacity (kW) / I.Power (W) / COP			3.30 / 1.37k / 2.41			3.90 / 1.72k / 2.27				
Max Current (A) / Max Input Power (W)			6.4 / 1.44k			9.2 / 2.07k				
Starting Current (A)			4.70			6.05				

Model			Indoor	CS-TE35TKEW	CS-TE42TKEW	
			Outdoor	CU-TE35TKE	CU-TE42TKE	
Compressor	Type			Hermetic Motor (Rotary)	Hermetic Motor (Rotary)	
	Motor Type			Brushless (6 poles)	Brushless (6 poles)	
	Output Power		W	700	700	
Indoor Fan	Type			Cross-Flow Fan	Cross-Flow Fan	
	Material			ASG20K1	ASG20K1	
	Motor Type			DC / Transistor (8-poles)	DC / Transistor (8-poles)	
	Input Power		W	47.3	47.3	
	Output Power		W	30	30	
	Speed	QLo	Cool	rpm	630	870
			Heat	rpm	730	920
		Lo	Cool	rpm	900	930
			Heat	rpm	1020	1100
		Me	Cool	rpm	1100	1170
			Heat	rpm	1200	1280
		Hi	Cool	rpm	1310	1410
			Heat	rpm	1380	1470
	SHi	Cool	rpm	1360	1460	
Heat		rpm	1430	1500		
Outdoor Fan	Type			Propeller Fan	Propeller Fan	
	Material			PP	PP	
	Motor Type			DC (8-poles)	DC (8-poles)	
	Input Power		W	-	-	
	Output Power		W	40	40	
	Speed	Hi	Cool	rpm	830	900
Heat			rpm	880	910	
Moisture Removal			L/h (Pt/h)	2.0 (4.2)	2.4 (5.1)	
Indoor Airflow	QLo	Cool	m ³ /min (ft ³ /min)	5.27 (186)	7.21 (255)	
		Heat	m ³ /min (ft ³ /min)	6.23 (220)	7.69 (272)	
	Lo	Cool	m ³ /min (ft ³ /min)	7.86 (278)	7.78 (275)	
		Heat	m ³ /min (ft ³ /min)	9.02 (319)	9.40 (332)	
	Me	Cool	m ³ /min (ft ³ /min)	9.78 (345)	10.06 (355)	
		Heat	m ³ /min (ft ³ /min)	10.74 (379)	11.11 (392)	
	Hi	Cool	m ³ /min (ft ³ /min)	11.80 (415)	12.30 (435)	
		Heat	m ³ /min (ft ³ /min)	12.50 (440)	12.90 (455)	
	SHi	Cool	m ³ /min (ft ³ /min)	12.28 (434)	12.82 (453)	
		Heat	m ³ /min (ft ³ /min)	12.95 (457)	13.20 (466)	
Outdoor Airflow	Hi	Cool	m ³ /min (ft ³ /min)	28.70 (1015)	33.60 (1185)	
		Heat	m ³ /min (ft ³ /min)	30.40 (1075)	34.00 (1200)	
Refrigeration Cycle	Control Device			Expansion Valve	Expansion Valve	
	Refrigerant Oil		cm ³	FV50S (320)	FV50S (320)	
	Refrigerant Type		g (oz)	R410A, 950 (33.5)	R410A, 1.01k (35.7)	
F-Gas	GWP			2088	2088	
	CO ₂ eq (ton) (Precharged Amount / Maximum Charged Amount)			1.984 / 2.297	2.109 / 2.422	
Dimension	Height (I/D / O/D)		mm (inch)	290 (11-7/16) / 542 (21-11/32)	290 (11-7/16) / 619 (24-3/8)	
	Width (I/D / O/D)		mm (inch)	799 (31-15/32) / 780 (30-23/32)	799 (31-15/32) / 824 (32-15/32)	
	Depth (I/D / O/D)		mm (inch)	197 (7-25/32) / 289 (11-13/32)	197 (7-25/32) / 299 (11-25/32)	
Weight	Net (I/D / O/D)		kg (lb)	8 (18) / 32 (71)	8 (18) / 32 (71)	

Model		Indoor	CS-TE35TKEW		CS-TE42TKEW	
		Outdoor	CU-TE35TKE		CU-TE42TKE	
Piping	Pipe Diameter (Liquid / Gas)	mm (inch)	6.35 (1/4) / 9.52 (3/8)		6.35 (1/4) / 12.70 (1/2)	
	Standard length	m (ft)	5.0 (16.4)		5.0 (16.4)	
	Length range (min – max)	m (ft)	3 (9.8) ~ 15 (49.2)		3 (9.8) ~ 15 (49.2)	
	I/D & O/D Height different	m (ft)	15.0 (49.2)		15.0 (49.2)	
	Additional Gas Amount	g/m (oz/ft)	20 (0.2)		20 (0.2)	
	Length for Additional Gas	m (ft)	7.5 (24.6)		7.5 (24.6)	
Drain Hose	Inner Diameter	mm	16.7		16.7	
	Length	mm	650		650	
Indoor Heat Exchanger	Fin Material		Aluminium (Pre Coat)		Aluminium (Pre Coat)	
	Fin Type		Slit Fin		Slit Fin	
	Row × Stage × FPI		2 × 15 × 17		2 × 15 × 21	
	Size (W × H × L)	mm	610 × 315 × 25.4		610 × 315 × 25.4	
Outdoor Heat Exchanger	Fin Material		Aluminium		Aluminium	
	Fin Type		Corrugated Fin		Corrugated Fin	
	Row × Stage × FPI		2 × 24 × 17		2 × 28 × 17	
	Size (W × H × L)	mm	36.4 × 504 × 713:684		36.38 × 588 × 606.6	
Air Filter	Material		Polypropelene		Polypropelene	
	Type		One-touch		One-touch	
Power Supply			Outdoor		Outdoor	
Power Supply Cord		A	Nil		Nil	
Thermostat			Electronic Contol		Electronic Contol	
Protection Device			Electronic Contol		Electronic Contol	
			Dry Bulb	Wet Bulb	Dry Bulb	Wet Bulb
Indoor Operation Range	Cooling	Maximum °C	32	23	32	23
		Minimum °C	16	11	16	11
	Heating	Maximum °C	30	–	30	–
		Minimum °C	16	–	16	–
Outdoor Operation Range	Cooling	Maximum °C	43	26	43	26
		Minimum °C	-10	–	-10	–
	Heating	Maximum °C	24	18	24	18
		Minimum °C	-15	-16	-15	-16

- Cooling capacities are based on indoor temperature of 27°C Dry Bulb (80.6°F Dry Bulb), 19.0°C Wet Bulb (66.2°F Wet Bulb) and outdoor air temperature of 35°C DRY BULB (95°F Dry Bulb), 24°C Wet Bulb (75.2°F Wet Bulb)
- Heating capacities are based on indoor temperature of 20°C Dry Bulb (68°F Dry Bulb) and outdoor air temperature of 7°C Dry Bulb (44.6°F Dry Bulb), 6°C Wet Bulb (42.8°F Wet Bulb)
- Heating low temperature capacity, Input Power and COP measured at 230 V, indoor temperature 20°C, outdoor 2/1°C
- Heating extreme low temperature capacity, Input Power and COP measured at 230 V, indoor temperature 20°C, outdoor -7/-8°C
- Standby power consumption ≤10.0w (when switched OFF by remote control, except under self protection control).
- Specifications are subjected to change without prior notice for further improvement.

• **Multi Split Combination Possibility:**

- A single outdoor unit enables air conditioning of up to two separate rooms for CU-2RE15SBE, CU-2RE18SBE.
- A single outdoor unit enables air conditioning of up to three separate rooms for CU-3RE18SBE.

CONNECTABLE INDOOR UNIT			OUTDOOR UNIT						
			CU-2RE15SBE*		CU-2RE18SBE*		CU-3RE18SBE*		
ROOM			A	B	A	B	A	B	C
TYPE									
Wall	2.0kW	CS-TE20TKEW	●	●	●	●	●	●	●
	2.5kW	CS-TE25TKEW	●	●	●	●	●	●	●
	3.5kW	CS-TE35TKEW	●	●	●	●	●	●	●
	4.2kW	CS-TE42TKEW	–	–	●	●	●	●	●
	5.0kW	CS-TE50TKEW	–	–	●	●	●	●	●
Capacity range of connectable indoor units			From 4.0kW to 5.7kW		From 4.0kW to 7.5kW		From 4.5kW to 9.0kW		
Pipe length	1 room maximum pipe length (m)		20		20		25		
	Allowable elevation (m)		10		10		15		
	Total allowable pipe length (m)		30		30		50		
	Total pipe length for maximum chargeless length (m)		20		20		30		
	Additional gas amount over chargeless length (g/m)		15		15		20		
Note: "●": Available									
<p>Remarks for CU-2RE15SBE / CU-2RE18SBE</p> <p>1. The total nominal cooling capacity of indoor units that will be connected to outdoor unit must be within connectable capacity range of indoor unit. (as shown in the table above) Example: The indoor units' combination below is possible to connect to CU-2RE15SBE. (Total nominal capacity of indoor units is between 4.0kW to 5.7kW) 1) Two CS-TE20TKEW only. (Total nominal cooling capacity is 4.0kW)</p>									
<p>Remarks for CU-3RE18SBE</p> <p>1. The total nominal cooling capacity of indoor units that will be connected to outdoor unit must be within connectable capacity range of indoor unit. (as shown in the table above) Example: The indoor units' combination below is possible to connect to CU-3RE18SBE. (Total nominal capacity of indoor units is between 4.5kW to 9.0kW) 1) Two CS-TE25TKEW only. (Total nominal cooling capacity is 5.0kW)</p>									

Note*: Above outdoor unit is contains and operates with refrigerant R410A gas.

• **Multi Split Combination Possibility:**

- A single outdoor unit enables air conditioning of up to two separate rooms for CU-2E12SBE, CU-2E15SBE, CU-2E18SBE.
- A single outdoor unit enables air conditioning of up to three separate rooms for CU-3E23SBE.

CONNECTABLE INDOOR UNIT			CU-2E12SBE*		CU-2E15SBE*		CU-2E18SBE*		CU-3E23SBE*		
ROOM			A	B	A	B	A	B	A	B	C
Wall	2.0kW	CS-TE20TKEW	•	•	•	•	•	•	•	•	•
	2.5kW	CS-TE25TKEW	•	•	•	•	•	•	•	•	•
	3.5kW	CS-TE35TKEW	•	•	•	•	•	•	•	•	•
	4.2kW	CS-TE42TKEW	–	–	–	–	•	•	•	•	•
	5.0kW	CS-TE50TKEW	–	–	–	–	•	•	•	•	•
	6.0kW	CS-TE60TKEW	–	–	–	–	–	–	•	•	•
Capacity range of connectable units			From 3.2kW to 5.7kW		From 3.2kW to 5.7kW		From 3.2kW to 7.5kW		From 4.5kW to 11.0kW		
Pipe length	1 room maximum pipe length (m)		20		20		20		25		
	Allowable elevation (m)		10		10		10		15		
	Total allowable pipe length (m)		30		30		30		60		
	Total pipe length for maximum chargeless length (m)		20		20		20		30		
	Additional gas amount over chargeless length (g/m)		15		15		15		20		
Note: “•” : Available											
Remarks for CU-2E12SBE / CU-2E15SBE / CU-2E18SBE											
1. The total nominal cooling capacity of indoor unit that will be connected to outdoor unit must be within connectable capacity range of indoor unit. (as shown in the table above) Example: The indoor units' combination below is possible to connect to CU-2E15SBE. (Total nominal capacity of indoor units is between 3.2kW to 5.7kW) 1) Two CS-TE20TKEW only. (Total nominal cooling capacity is 4.0kW)											
Remarks for CU-3E23SBE											
1. The total nominal cooling capacity of indoor unit that will be connected to outdoor unit must be within connectable capacity range of indoor unit. (as shown in the table above) Example: The indoor units' combination below is possible to connect to CU-3E23SBE. (Total nominal capacity of indoor units is between 4.5kW to 11.0kW) 1) Two CS-TE25TKEW only. (Total nominal cooling capacity is 5.0kW)											

Note*: Above outdoor unit is contains and operates with refrigerant R410A gas.

• **Multi Split Combination Possibility:**

- A single outdoor unit enables air conditioning of up to three separate rooms for CU-3E18PBE.
- A single outdoor unit enables air conditioning of up to four separate rooms for CU-4E23PBE, CU-4E27PBE.
- A single outdoor unit enables air conditioning of up to five separate rooms for CU-5E34PBE.

CONNECTABLE INDOOR UNIT			CU-3E18PBE*			CU-4E23PBE*				CU-4E27PBE*				CU-5E34PBE*				
ROOM			A	B	C	A	B	C	D	A	B	C	D	A	B	C	D	E
Wall	2.0kW	CS-TE20TKEW	•	•	•	•	•	•	•	•	•	•	•	•	•	•	•	•
	2.5kW	CS-TE25TKEW	•	•	•	•	•	•	•	•	•	•	•	•	•	•	•	•
	3.5kW	CS-TE35TKEW	•	•	•	•	•	•	•	•	•	•	•	•	•	•	•	•
	4.2kW	CS-TE42TKEW	•	•	•	•	•	•	•	•	•	•	•	•	•	•	•	•
	5.0kW	CS-TE50TKEW	•	•	•	•	•	•	•	•	•	•	•	•	•	•	•	•
	6.0kW	CS-TE60TKEW	–	–	–	•	•	•	•	•	•	•	•	•	•	•	•	•
Capacity range of connectable units			From 4.5kW to 9.0kW			From 4.5kW to 11.0kW				From 4.5kW to 13.6kW				From 4.5kW to 17.5kW				
Pipe length	1 room maximum pipe length (m)		25			25				25				25				
	Allowable elevation (m)		15			15				15				15				
	Total allowable pipe length (m)		50			60				70				80				
	Total pipe length for maximum chargeless length (m)		30			30				45				45				
	Additional gas amount over chargeless length (g/m)		20			20				20				20				
Note: “•”: Available																		
<p>Remarks for CU-3E18PBE / CU-4E23PBE / CU-4E27PBE / CU-5E34PBE</p> <p>1. The total nominal cooling capacity of indoor unit that will be connected to outdoor unit must be within connectable capacity range of indoor unit. (as shown in the table above) Example: The indoor units' combination below is possible to connect to CU-4E27PBE. (Total nominal capacity of indoor units is between 4.5kW to 13.6kW) 1) Two CS-TE25TKEW only. (Total nominal cooling capacity is 5.0kW)</p>																		

Note*: Above outdoor unit is contains and operates with refrigerant R410A gas.

3. Features

- **Inverter Technology**
 - Wider output power range
 - Energy saving
 - Quick Cooling
 - Quick Heating
 - More precise temperature control
- **Environment Protection**
 - Non-ozone depletion substances refrigerant (R410A)
- **Long Installation Piping**
 - Long piping up to 15 meters (3/4 ~ 1.75HP) and 20 meters (2.0HP) during single split connection only
- **Easy to use remote control**
- **Quality Improvement**
 - Random auto restart after power failure for safety restart operation
 - Gas leakage protection
 - Prevent compressor reverse cycle
 - Inner protector to protect compressor
 - Noise prevention during soft dry operation
- **Operation Improvement**
 - Quiet mode to reduce the indoor unit operating sound
 - Powerful mode to reach the desired room temperature quickly
 - 24-hour timer setting
- **Serviceability Feature**
 - Breakdown Self Diagnosis function

4. Location of Controls and Components

4.1 Indoor Unit

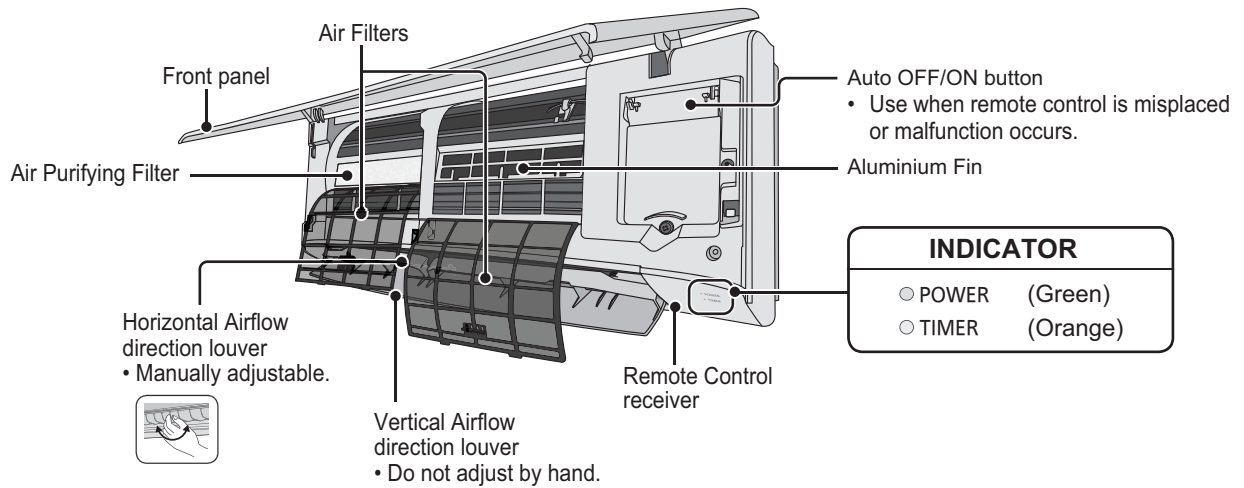

4.2 Outdoor Unit

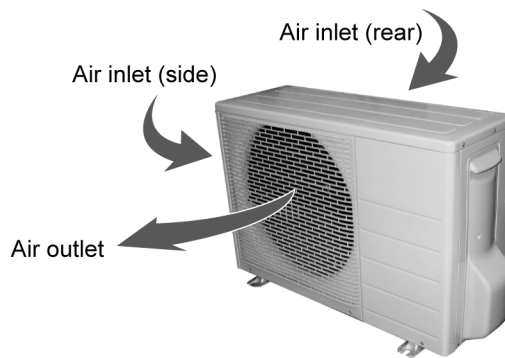

4.3 Remote Control

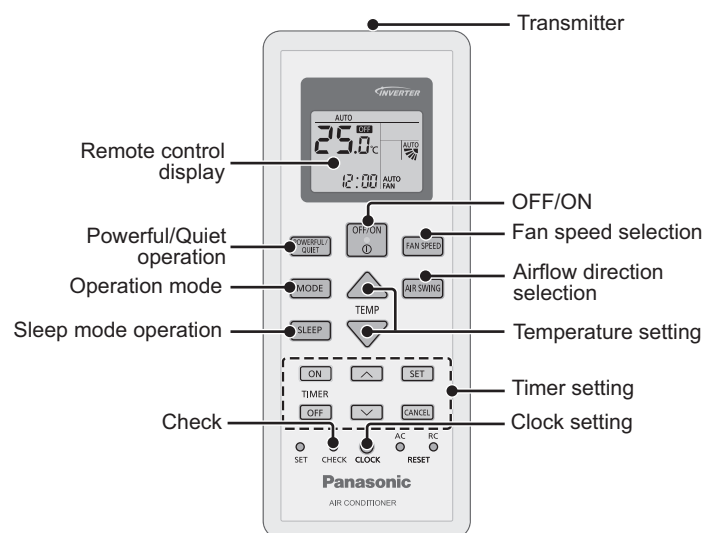

5. Dimensions

5.1 Indoor Unit

<Top View>

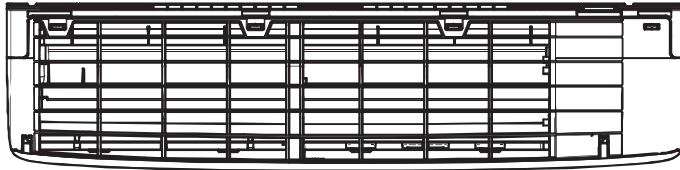

<Side View>

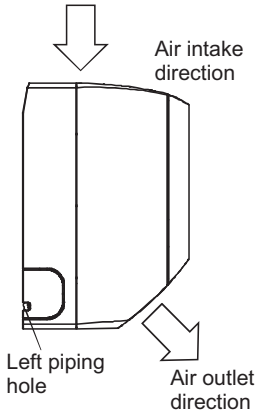

<Front View>

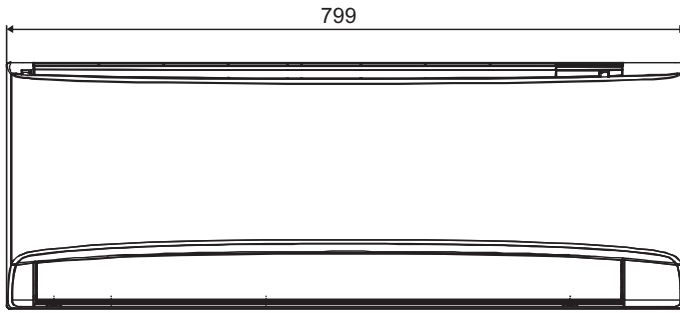

<Side View>

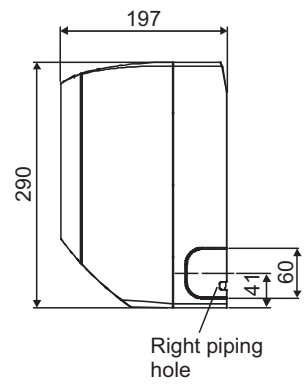

<Bottom View>

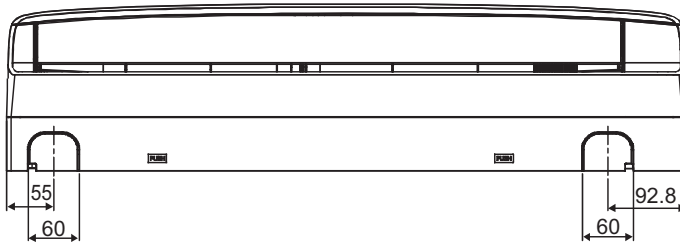

<Remote Control>

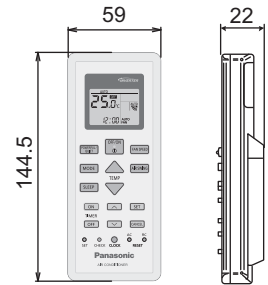

<Rear View>

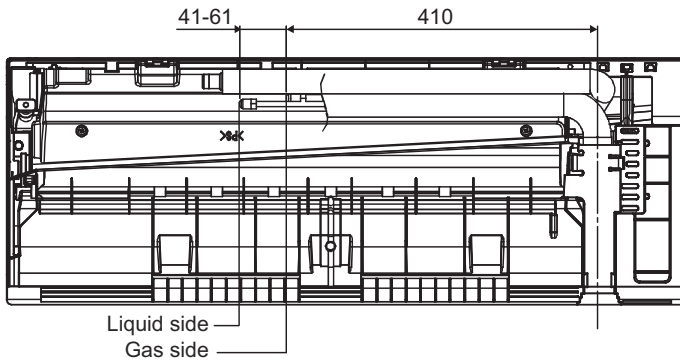

<Remote Control Holder>

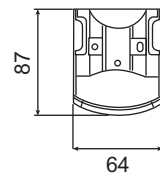

Relative position between the indoor unit and the installation plate <Front View>

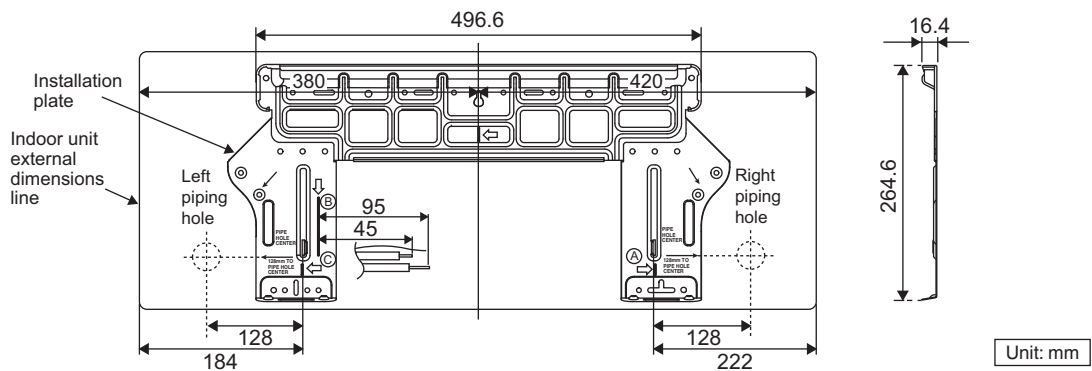

5.2 Outdoor Unit

5.2.1 CU-TE20TKE CU-TE25TKE CU-TE35TKE

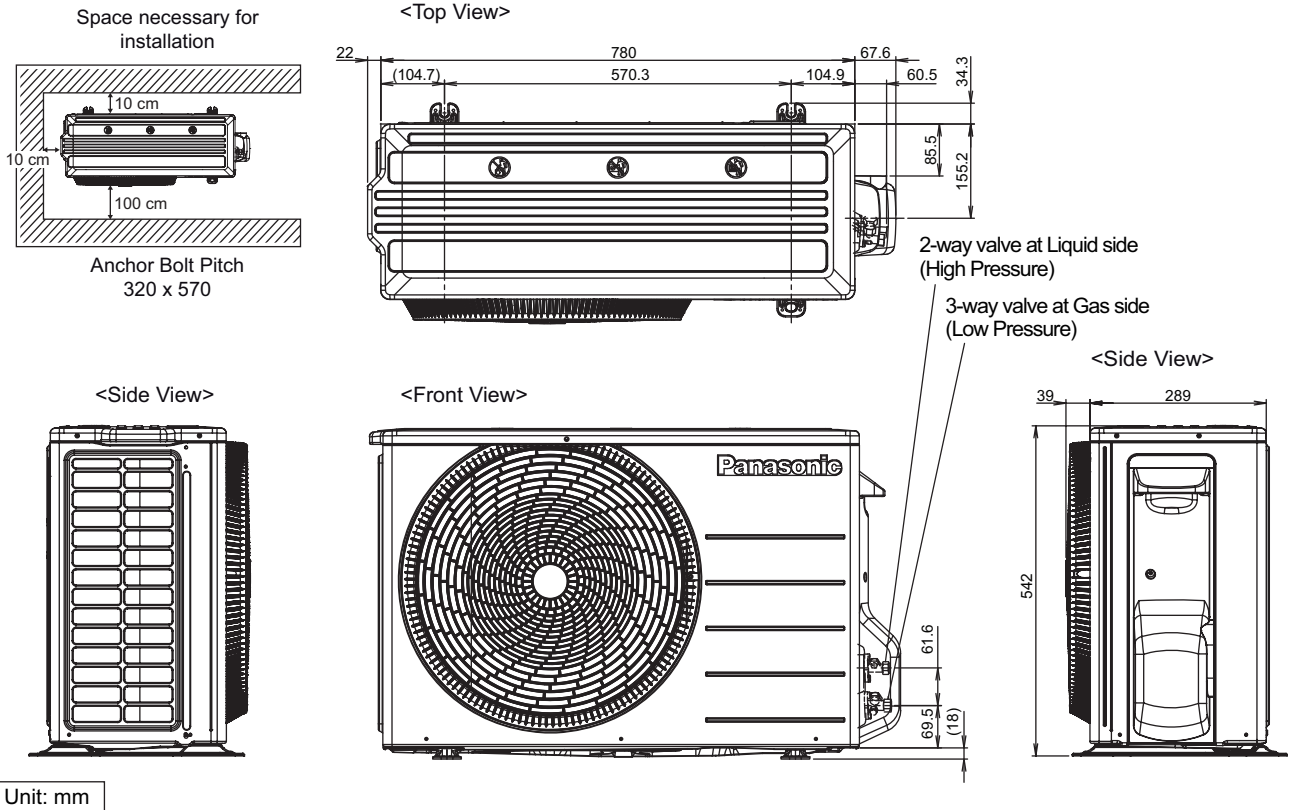

5.2.2 CU-TE42TKE

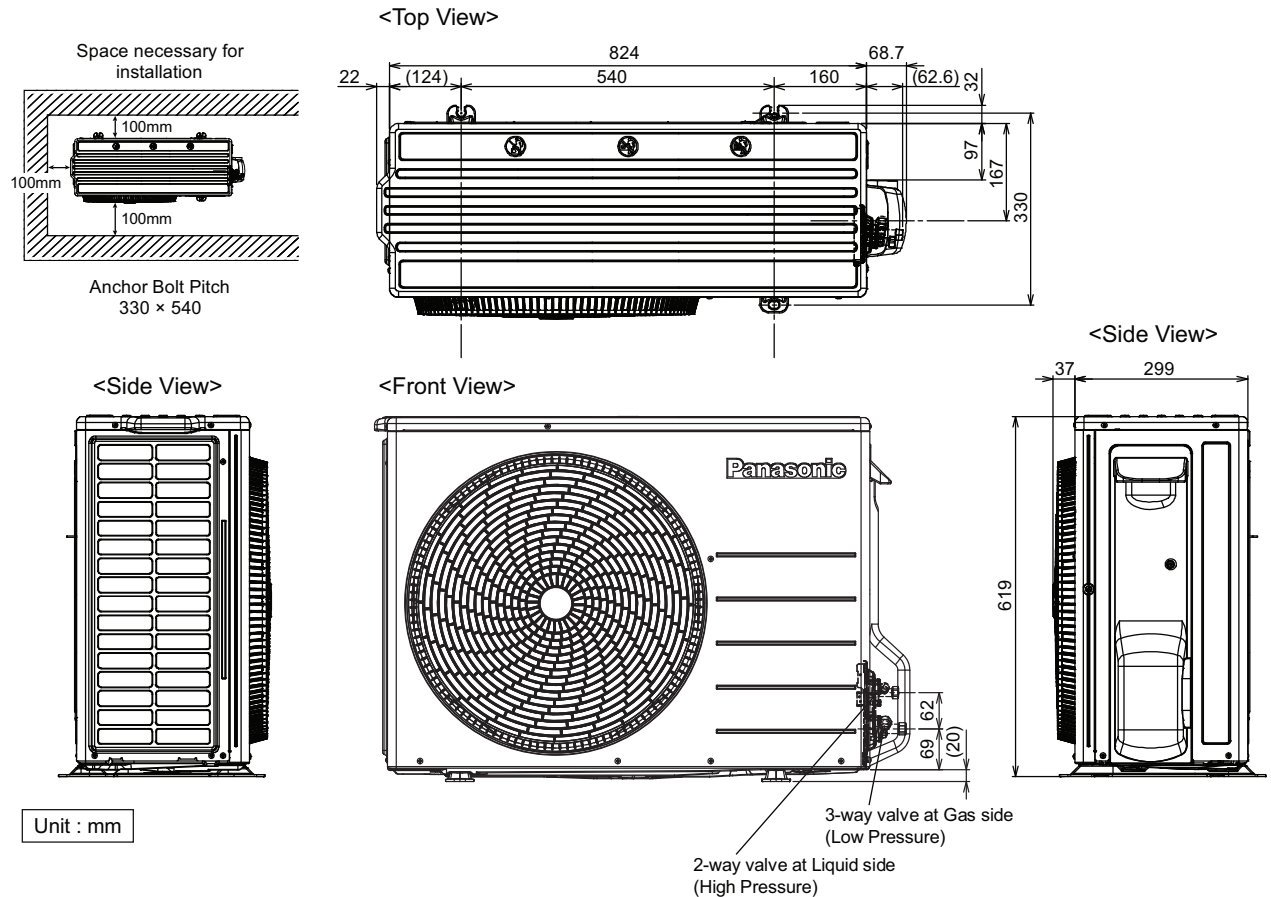

6. Refrigeration Cycle Diagram

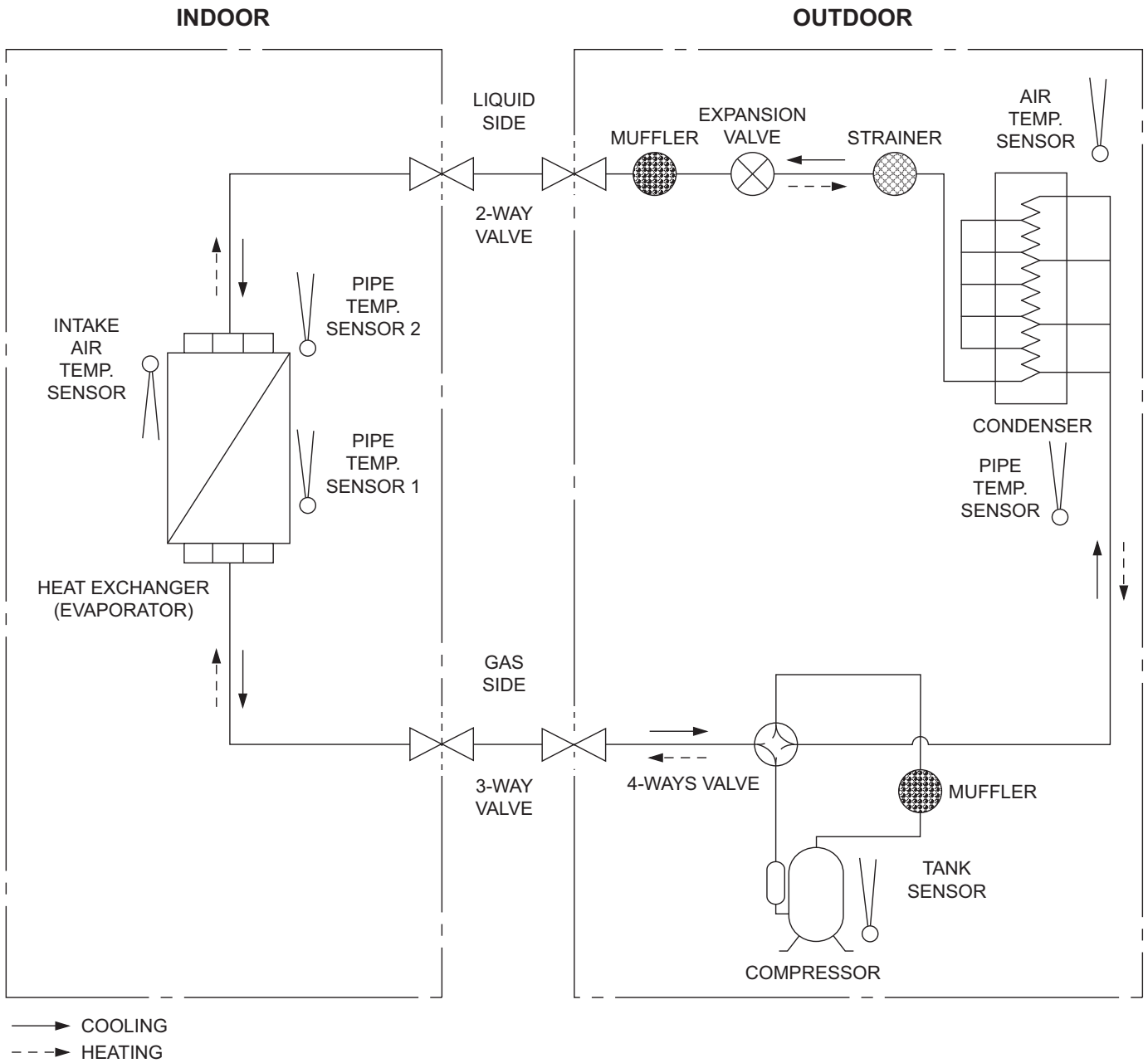

7. Block Diagram

7.1 Indoor Unit

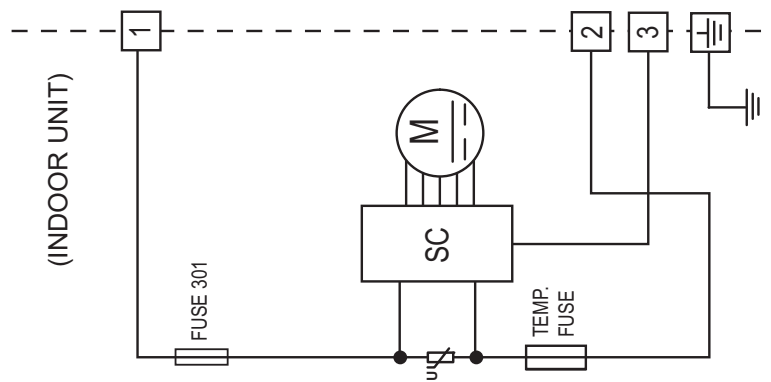

7.2 Outdoor Unit

7.2.1 CU-TE20TKE CU-TE25TKE

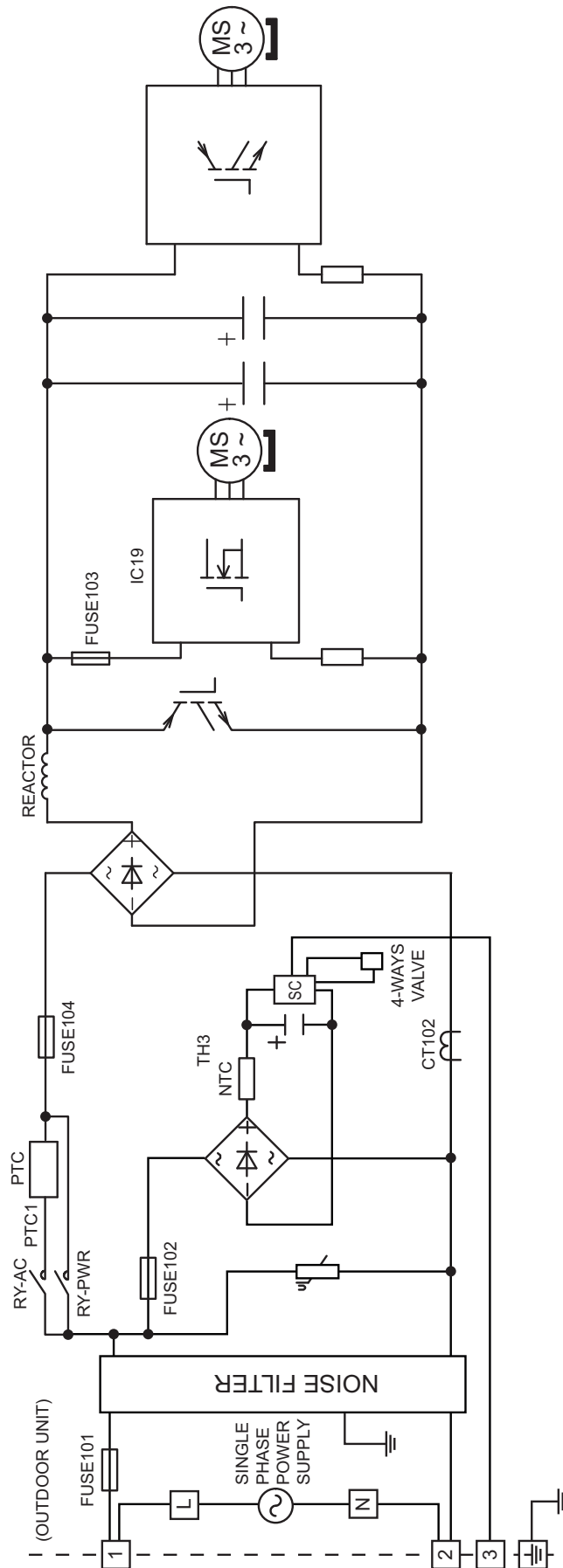

7.2.2 CU-TE35TKE

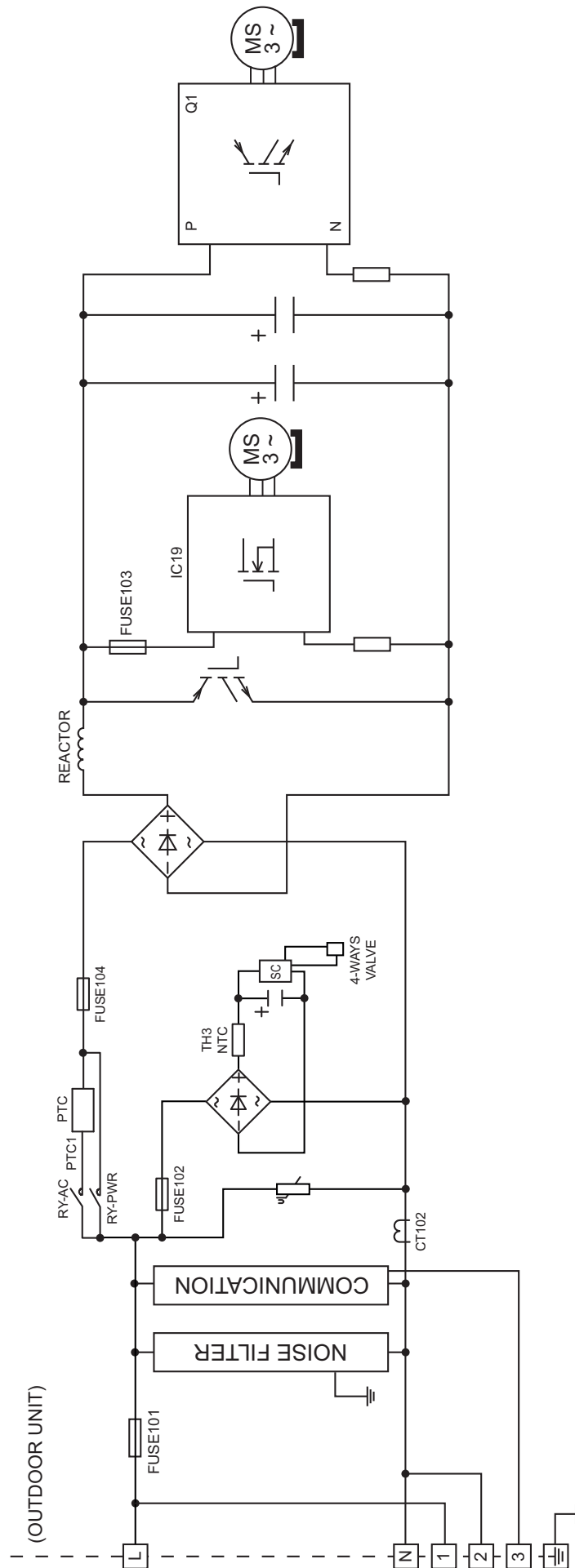

7.2.3 CU-TE42TKE

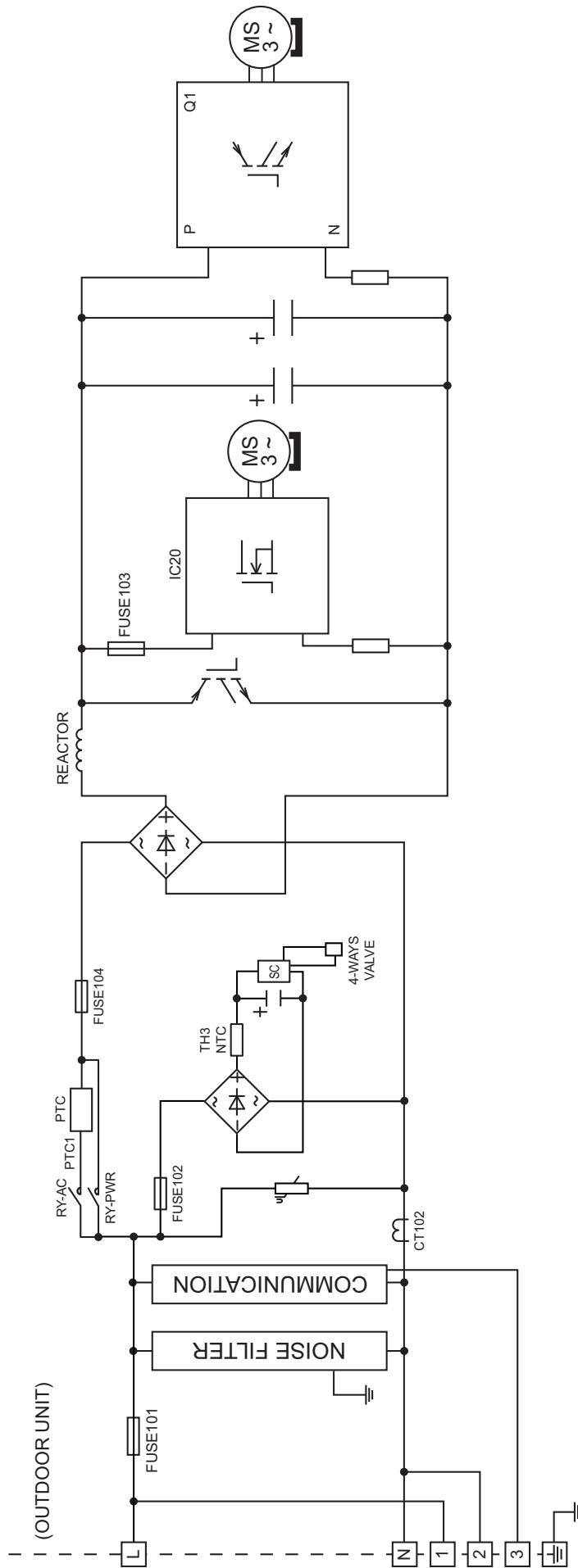

8. Wiring Connection Diagram

8.1 Indoor Unit

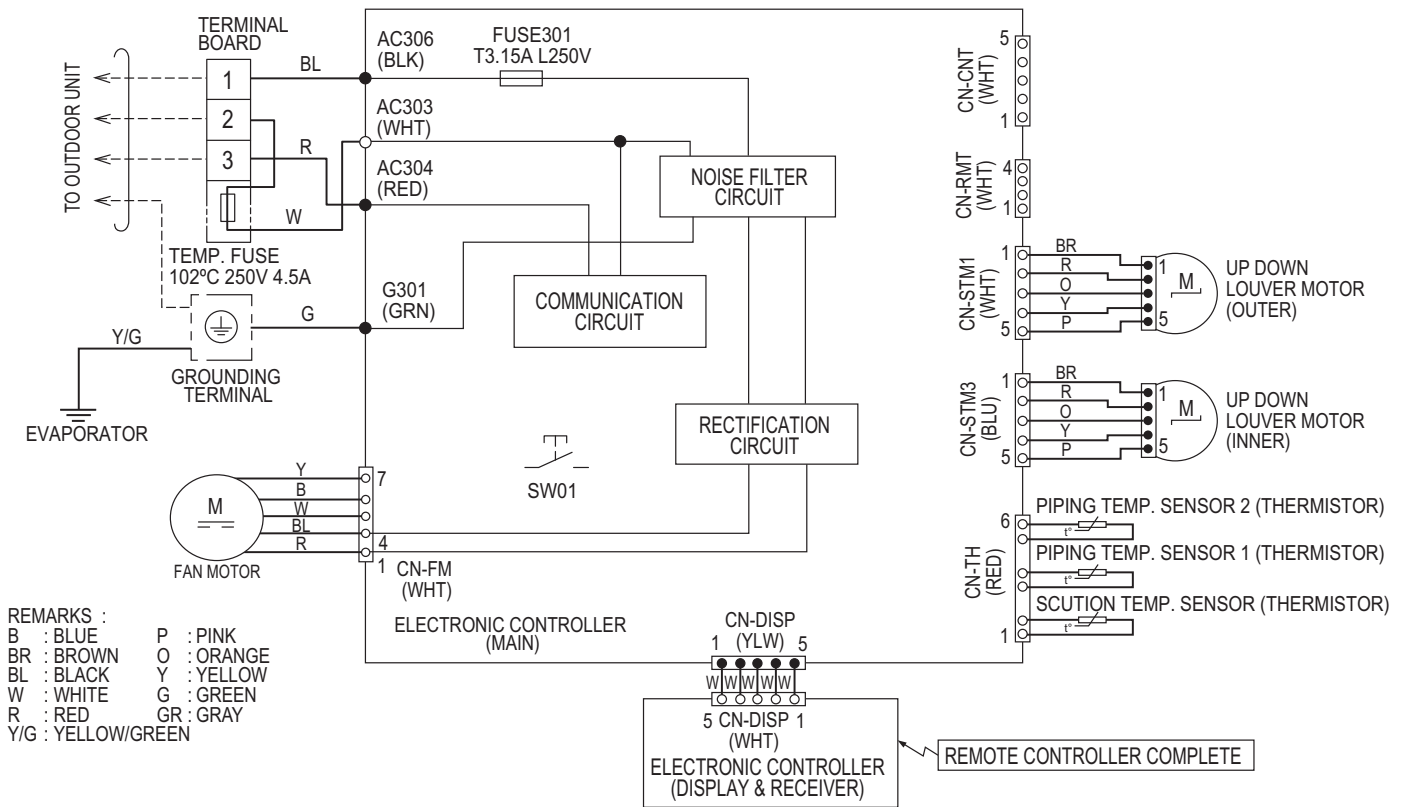

8.2 Outdoor Unit

8.2.1 CU-TE20TKE CU-TE25TKE

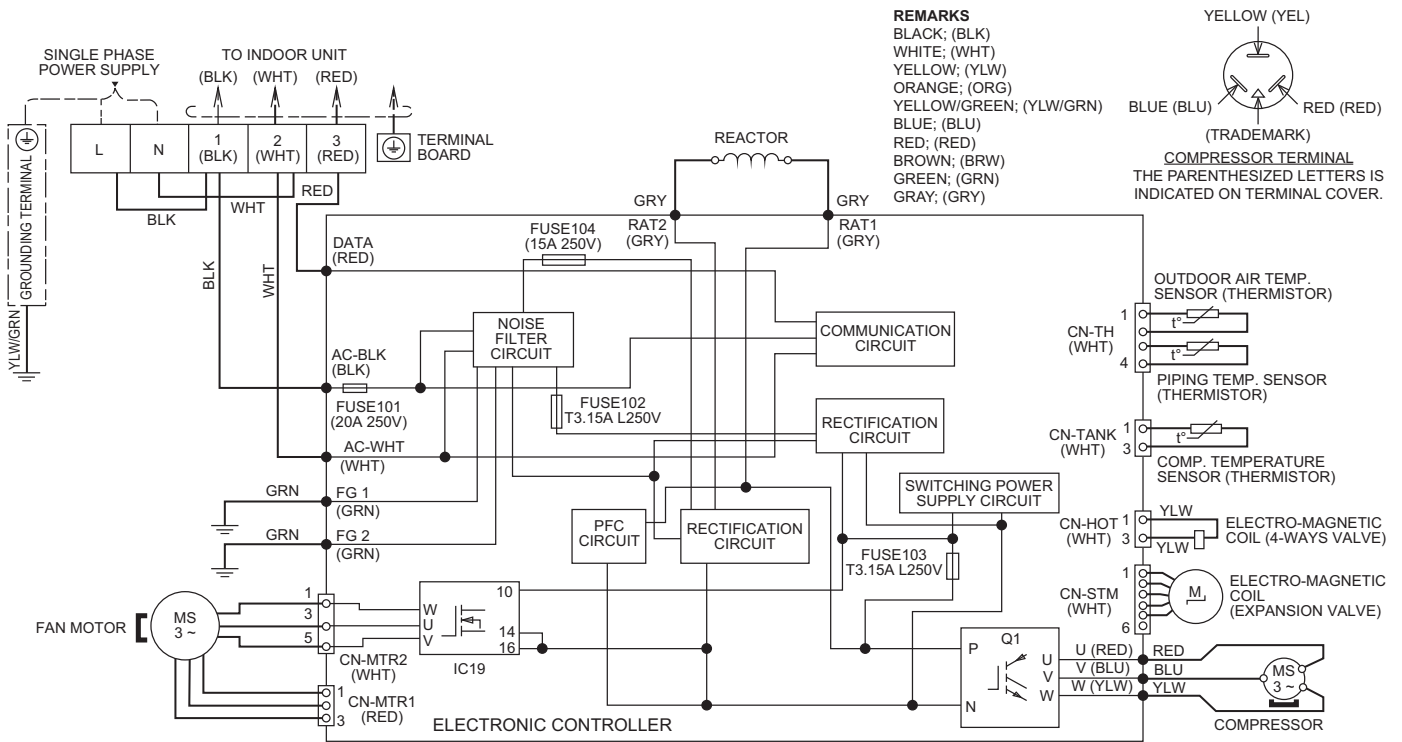

Resistance of Compressor Windings

MODEL	CU-TE20TKE / CU-TE25TKE
CONNECTION	5SS072XGA21 (Ω)
U-V	3.034
U-W	3.021
V-W	3.009

Note: Resistance at 20°C of ambient temperature.

8.2.2 CU-TE35TKE

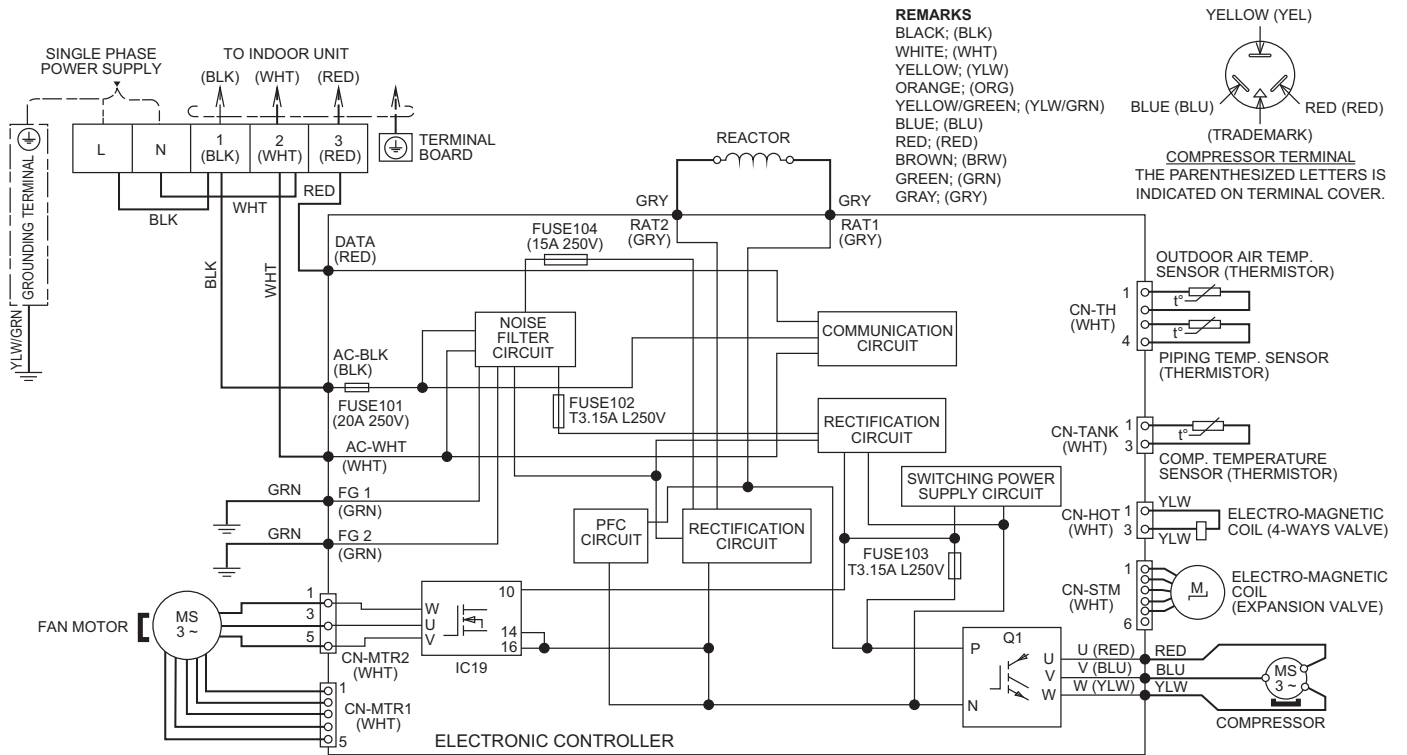

Resistance of Compressor Windings

MODEL	CU-TE35TKE
CONNECTION	5RS102XNA21 (Ω)
U-V	1.211
U-W	1.211
V-W	1.211

Note: Resistance at 20°C of ambient temperature.

8.2.3 CU-TE42TKE

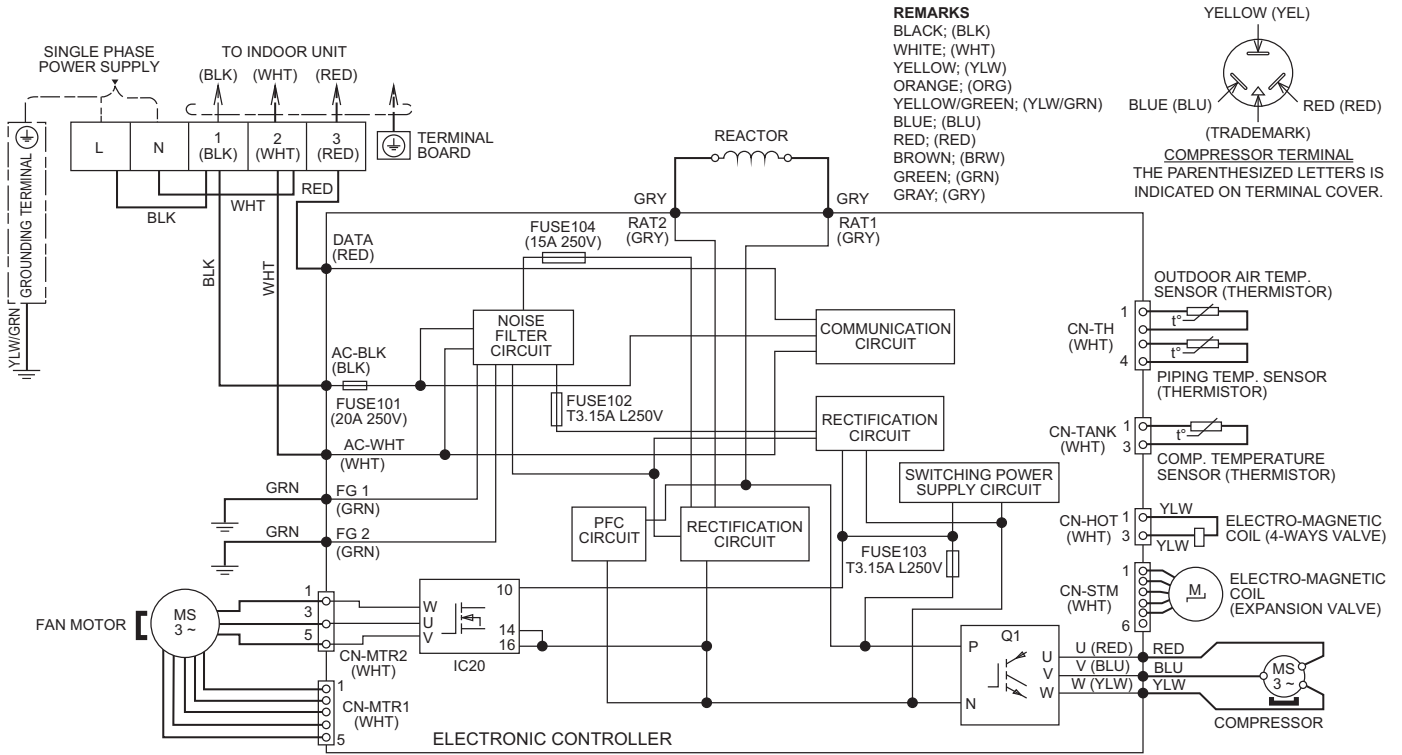

Resistance of Compressor Windings

MODEL	CU-TE42TKE
CONNECTION	5RS102XNA21 (Ω)
U-V	1.211
U-W	1.211
V-W	1.211

Note: Resistance at 20°C of ambient temperature.

9. Electronic Circuit Diagram

9.1 Indoor Unit

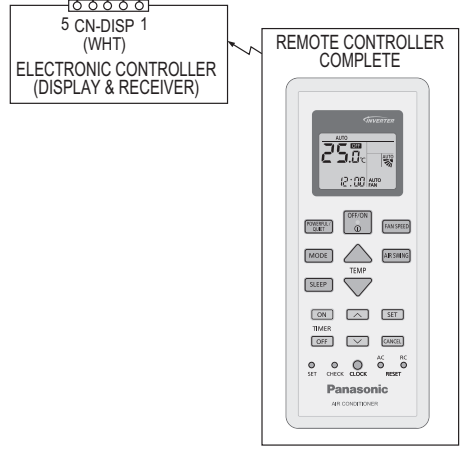
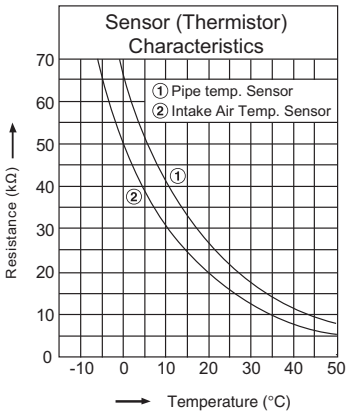
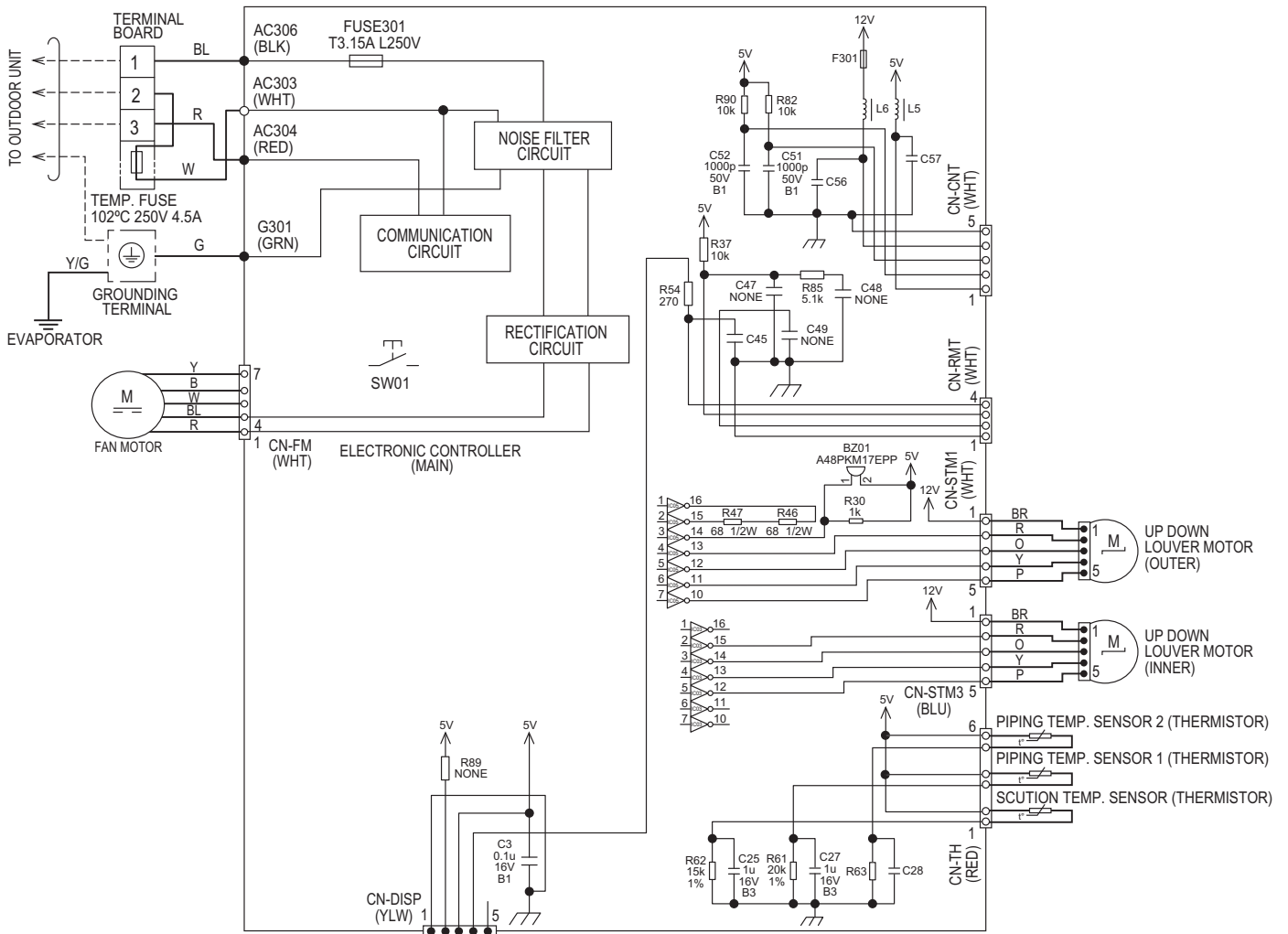

9.2 Outdoor Unit

9.2.1 CU-TE20TKE CU-TE25TKE

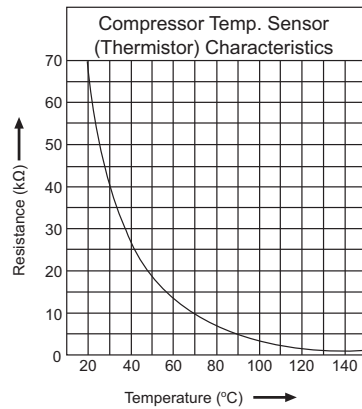
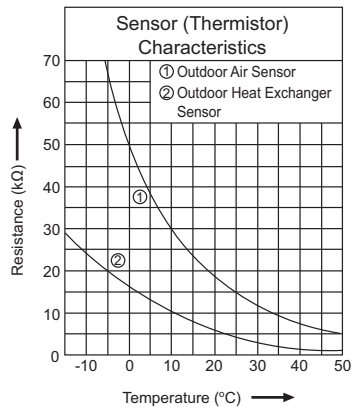
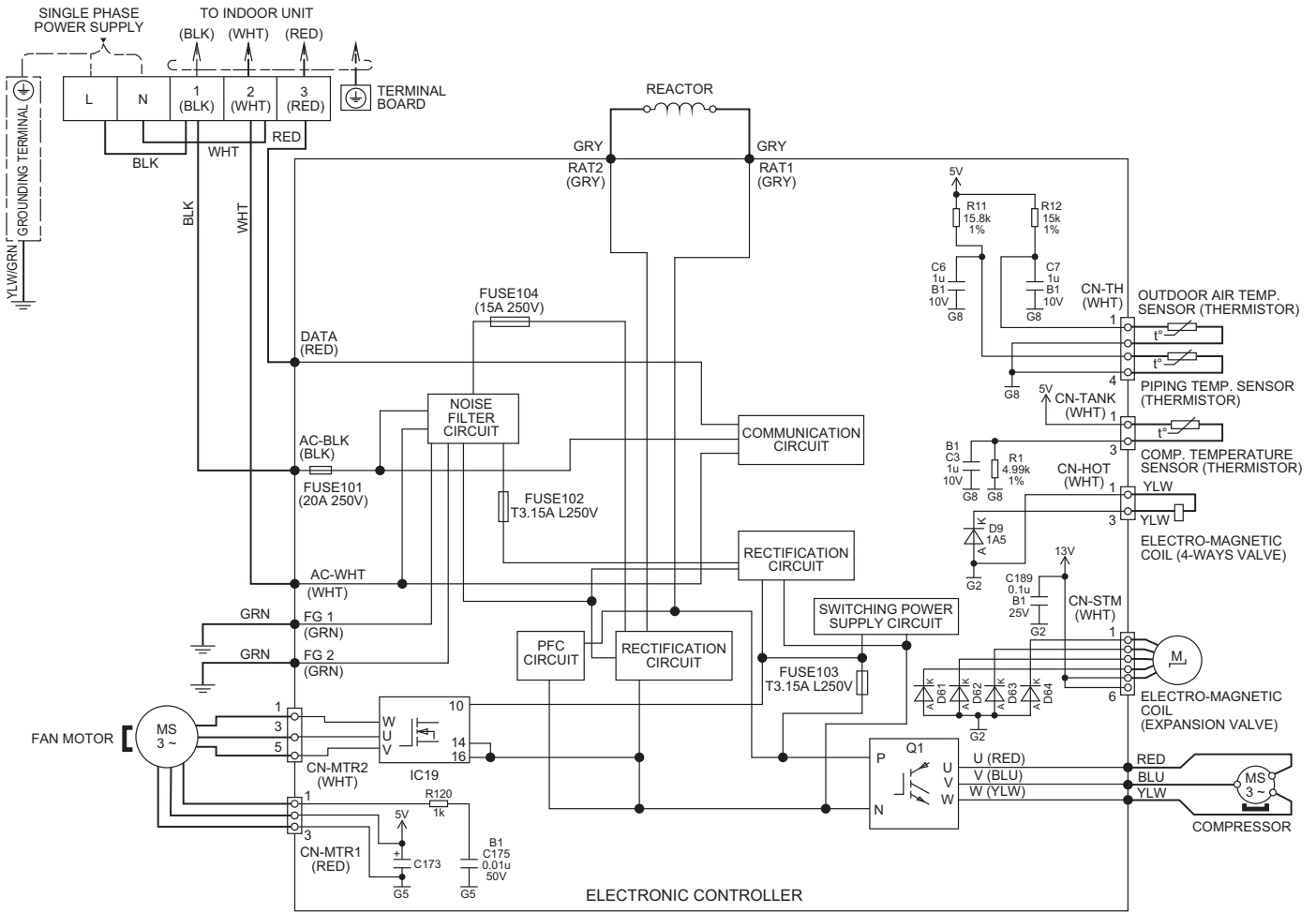

9.2.2 CU-TE35TKE

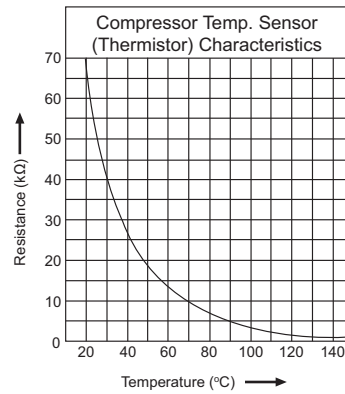
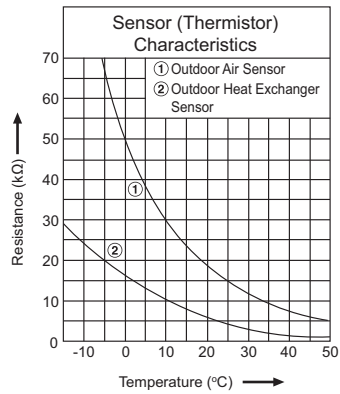
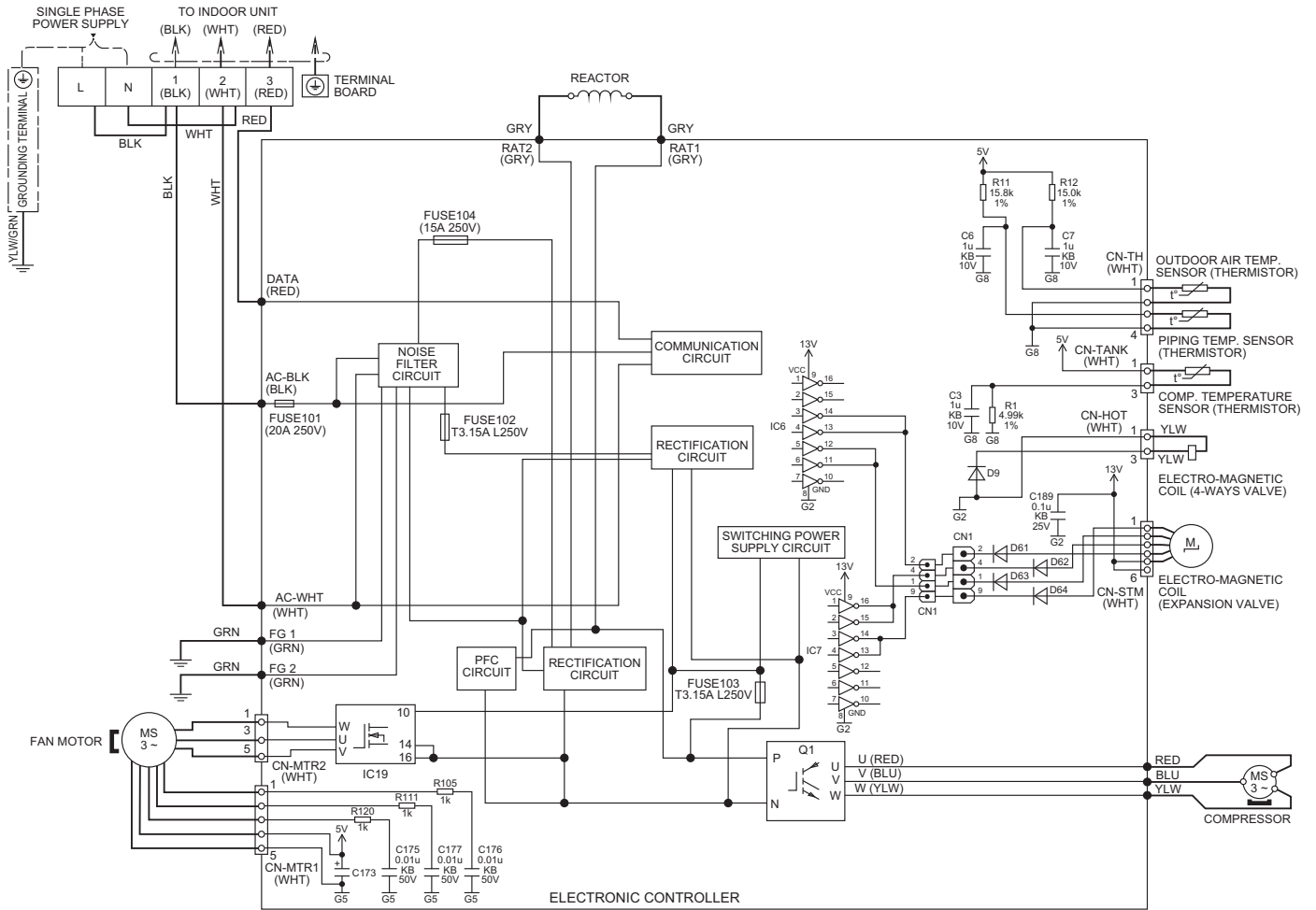

9.2.3 CU-TE42TKE

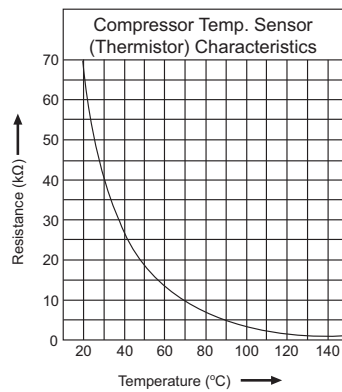
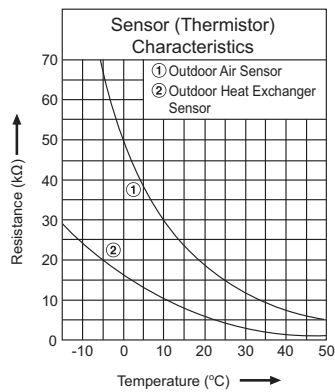
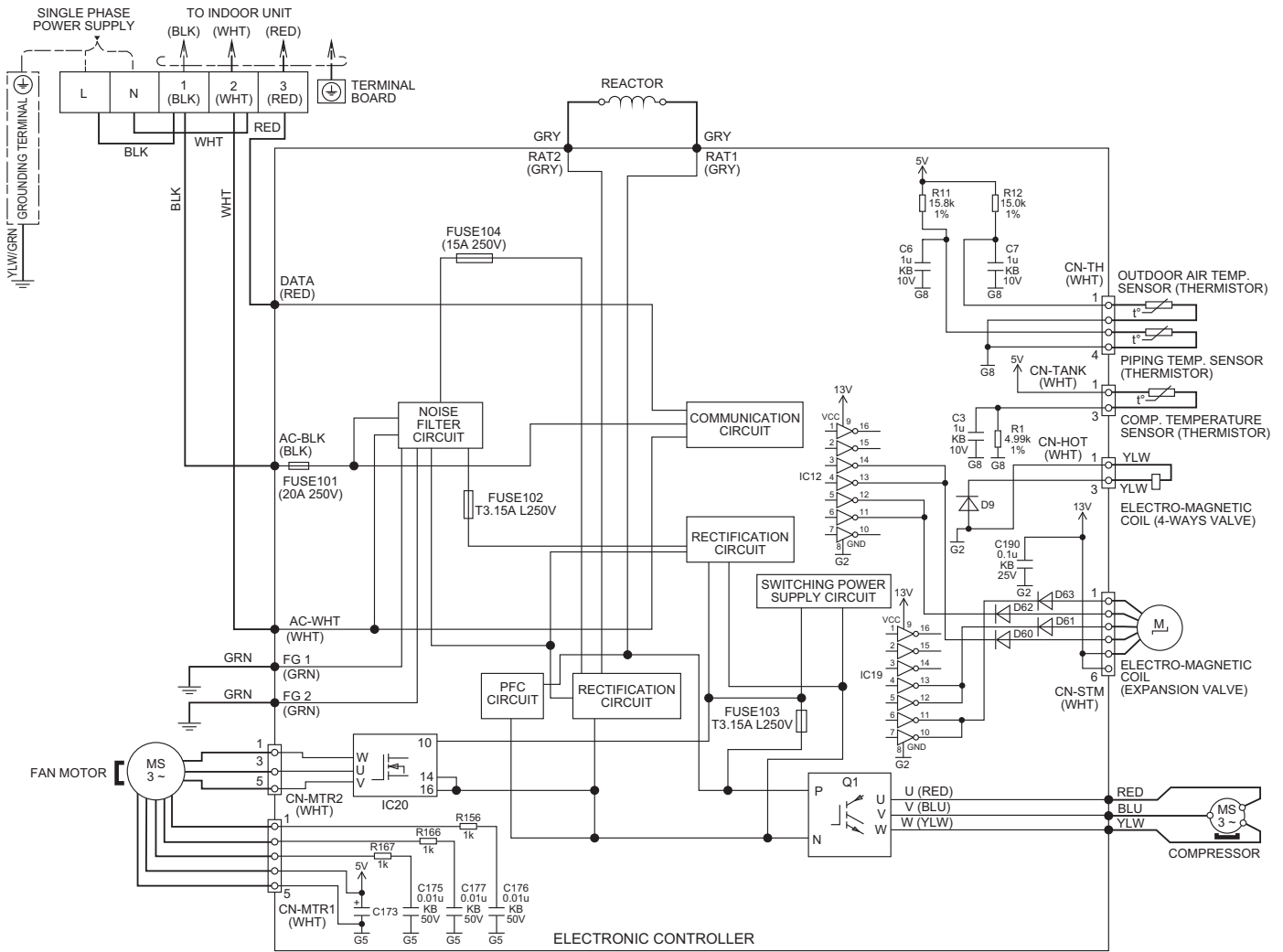

10. Printed Circuit Board

10.1 Indoor Unit

10.1.1 Main Printed Circuit Board

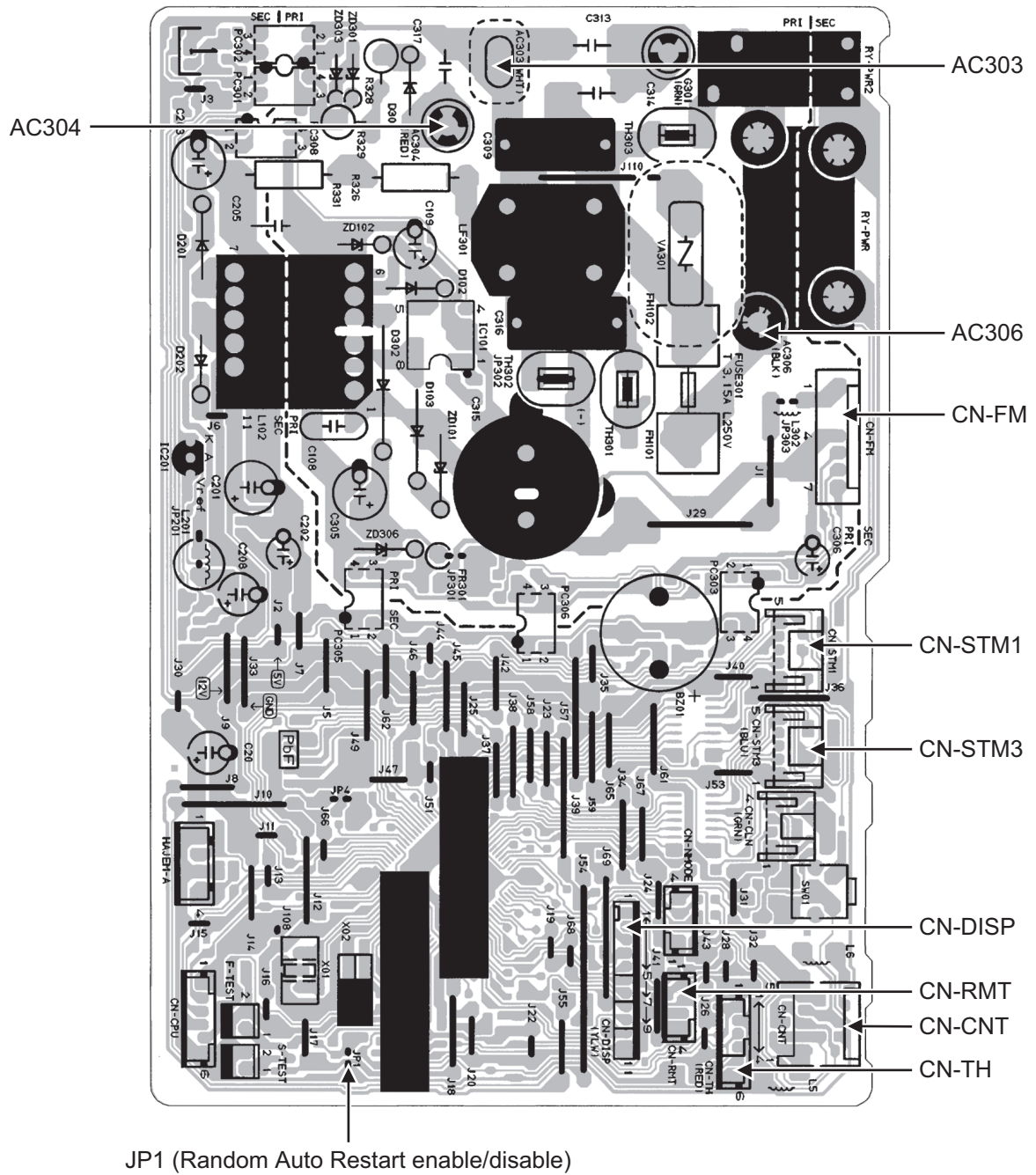

10.1.2 Indicator Printed Circuit Board

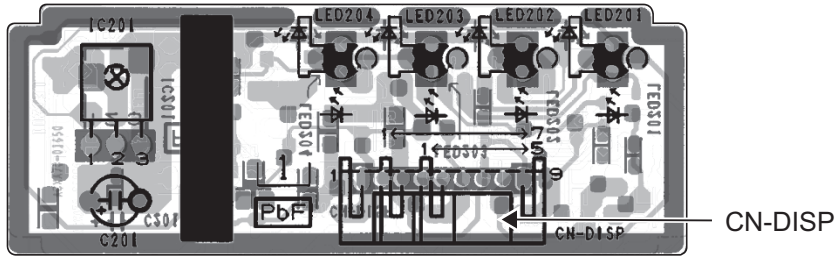

10.2 Outdoor Unit

10.2.1 CU-TE20TKE CU-TE25TKE

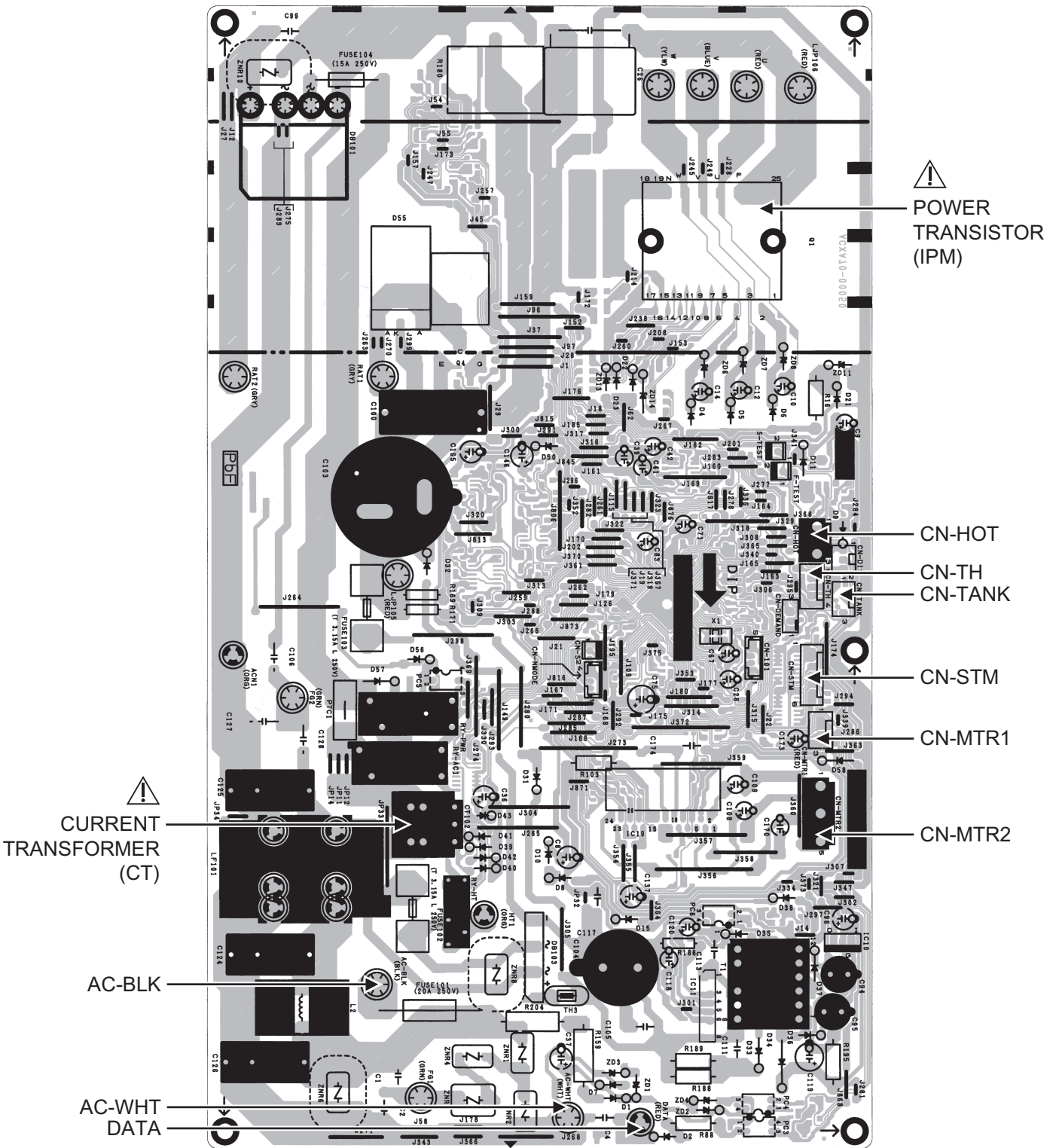

10.2.2 CU-TE35TKE

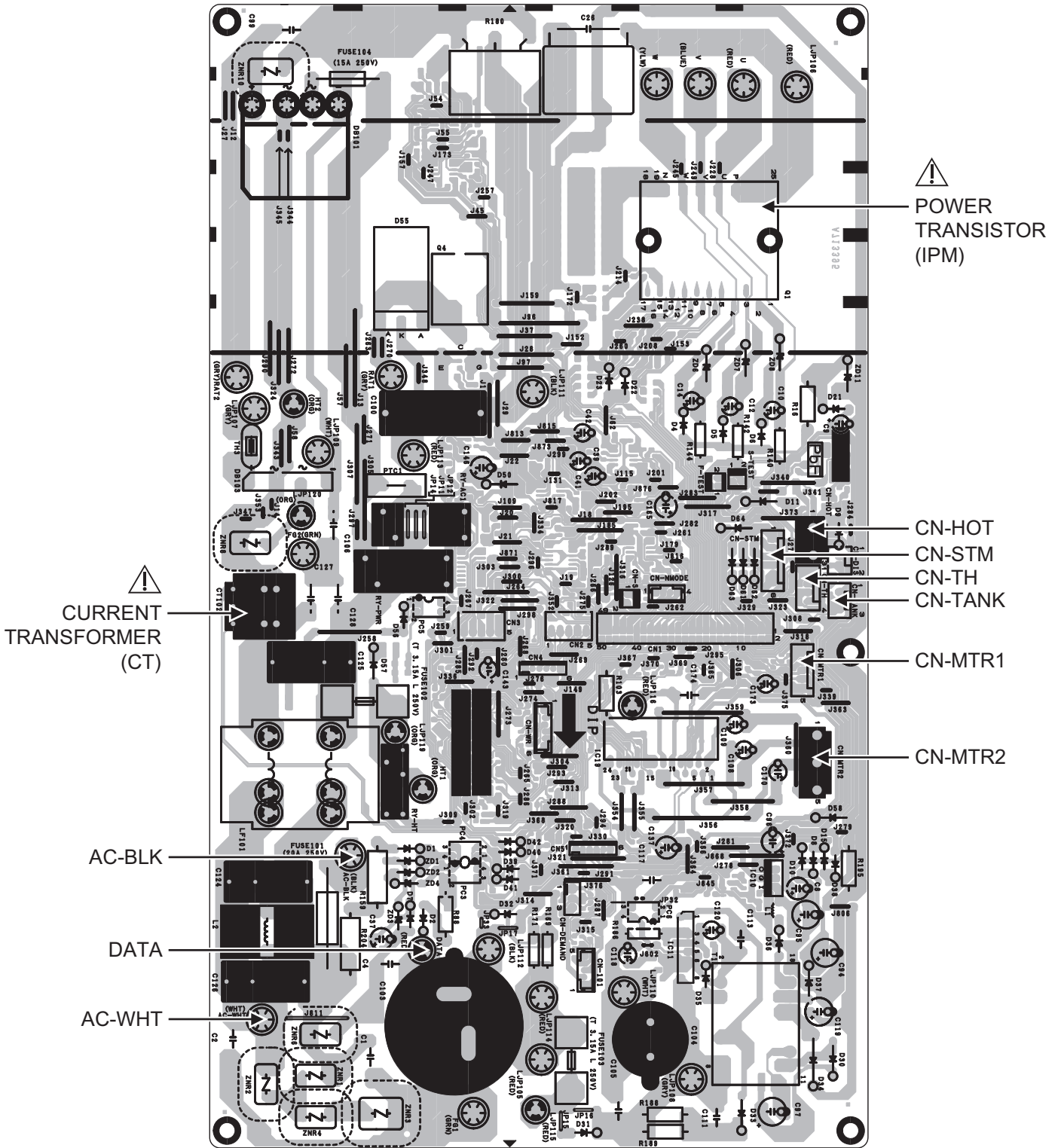

10.2.3 CU-TE42TKE

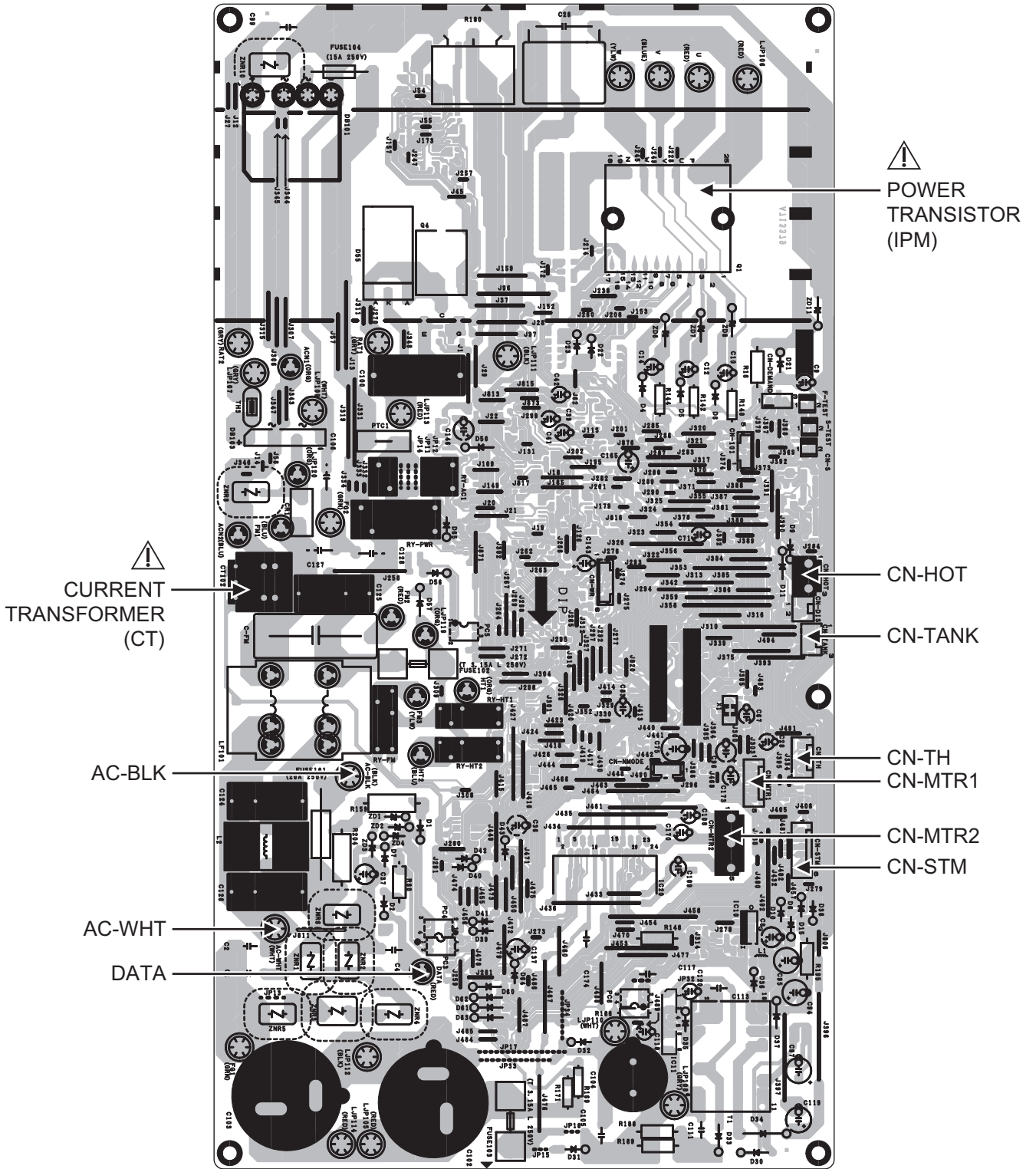

11. Installation Instruction

11.1 Select the Best Location

11.1.1 Indoor Unit

- Do not install the unit in excessive oil fume area such as kitchen, workshop and etc.
- There should not be any heat source or steam near the unit.
- There should not be any obstacles blocking the air circulation.
- A place where air circulation in the room is good.
- A place where drainage can be easily done.
- A place where noise prevention is taken into consideration.
- Do not install the unit near the door way.
- Ensure the spaces indicated by arrows from the wall, ceiling, fence or other obstacles.
- Recommended installation height for indoor unit shall be at least 2.5 m.

11.1.2 Outdoor Unit

- If an awning is built over the unit to prevent direct sunlight or rain, be careful that heat radiation from the condenser is not obstructed.
- There should not be any animal or plant which could be affected by hot air discharged.
- Keep the spaces indicated by arrows from wall, ceiling, fence or other obstacles.
- Do not place any obstacles which may cause a short circuit of the discharged air.
- If piping length is over the [piping length for additional gas], additional refrigerant should be added as shown in the table.

11.1.3 Indoor/Outdoor Unit Installation Diagram

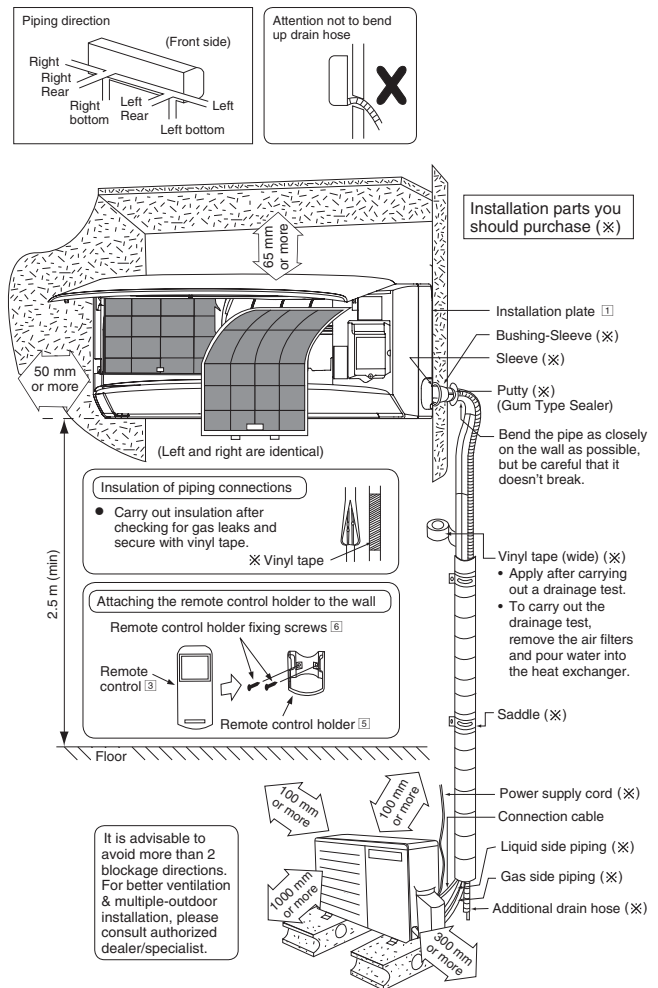

Table A

Model	Capacity W (HP)	Piping size		Std. Length (m)	Max Elevation (m)	Min. Piping Length (m)	Max. Piping Length (m)	Additional Refrigerant (g/m)	Piping Length for add. gas (m)
		Gas	Liquid						
TE20***	3/4HP	9.52 mm (3/8")	6.35 mm (1/4")	5	15	3	15	15	7.5
TE25***	1.0HP				15	3	15	15	7.5
TE35***	1.5HP				15	3	15	20	7.5
TE42***	1.75HP				12.7 mm (1/2")	15	3	15	20

* Table "A" only applicable for single split connection.

* In case of connection to outdoor multi inverter, refer to installation manual at outdoor unit.

Example: For TE35***

If the unit is installed at 10 m distance, the quantity of additional refrigerant should be 50 g (10-7.5) m x 20 g/m = 50 g.

- This illustration is for explanation purposes only. The indoor unit will actually face a different way.

11.2 Indoor Unit

11.2.1 How to Fix Installation Plate

The mounting wall shall be strong and solid enough to prevent it from vibration.

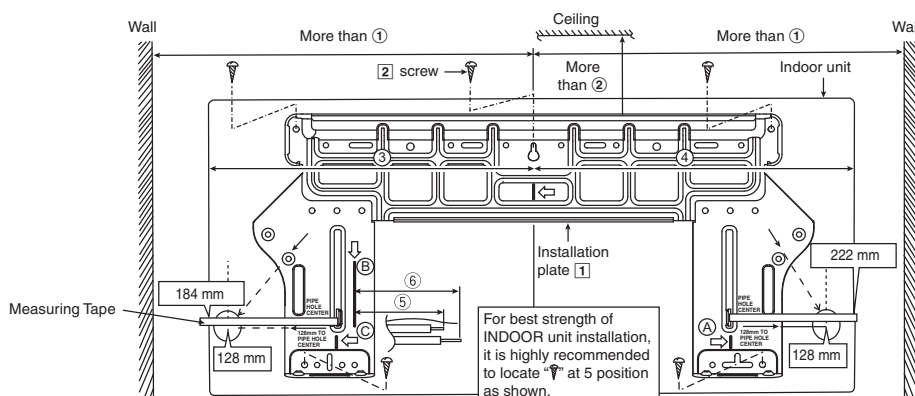

Model	Dimension					
	①	②	③	④	⑤	⑥
MTE16***, TZ20***, TE20*** TZ25***, TE25*** TZ35***, TE35*** TZ42***, TE42***	470 mm	90 mm	380 mm	420 mm	45 mm	95 mm

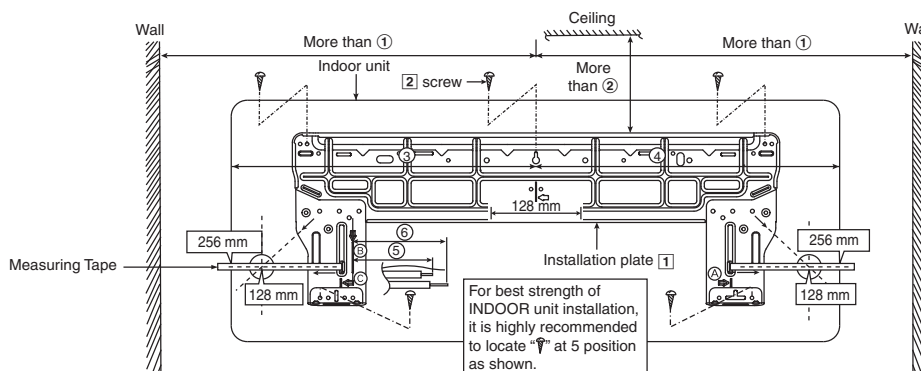

Model	Dimension					
	①	②	③	④	⑤	⑥
TZ50***, TE50*** TZ60***, TE60*** TZ71***	605 mm	95 mm	550 mm	550 mm	270 mm	320 mm

The center of installation plate should be at more than ① at right and left of the wall.

The distance from installation plate edge to ceiling should more than ②.

From installation plate center to unit's left side is ③.

From installation plate center to unit's right side is ④.

- Ⓑ : For left side piping, piping connection for liquid should be about ⑤ from this line.
: For left side piping, piping connection for gas should be about ⑥ from this line.

- Mount the installation plate on the wall with 5 screws or more (at least 5 screws).
(If mounting the unit on the concrete wall, consider using anchor bolts.)
 - Always mount the installation plate horizontally by aligning the marking-off line with the thread and using a level gauge.
- Drill the piping plate hole with $\varnothing 70$ mm hole-core drill.
 - Line according to the left and right side of the installation plate. The meeting point of the extended line is the center of the hole. Another method is by putting measuring tape at position as shown in the diagram above. The hole center is obtained by measuring the distance namely 128 mm for left and right hole respectively.
 - Drill the piping hole at either the right or the left and the hole should be slightly slanting to the outdoor side.

11.2.2 To Drill a Hole in the Wall and Install a Sleeve of Piping

- 1 Insert the piping sleeve to the hole.
- 2 Fix the bushing to the sleeve.
- 3 Cut the sleeve until it extrudes about 15 mm from the wall.



CAUTION

❗ When the wall is hollow, please be sure to use the sleeve for tube assembly to prevent dangers caused by mice biting the connection cable.

- 4 Finish by sealing the sleeve with putty or caulking compound at the final stage.

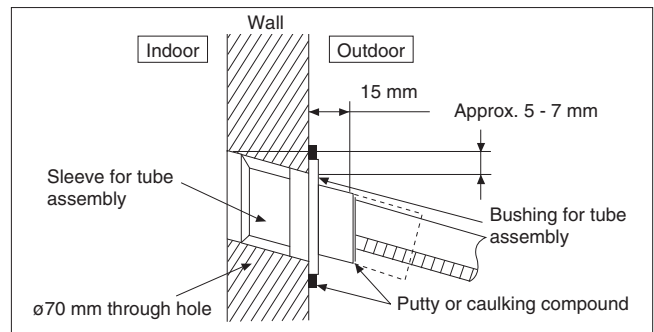

11.2.3 Indoor Unit Installation

- Do not turn over the unit without its shock absorber during pull out the piping. It may cause intake grille damage.
- Use shock absorber during pull out the piping to protect the intake grille from damage.

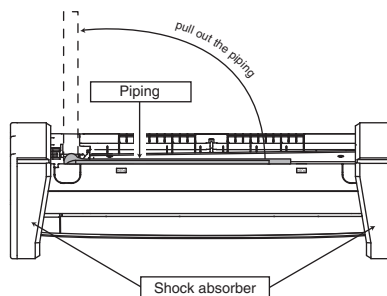
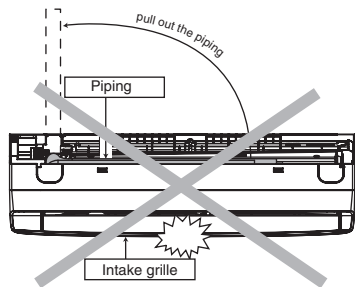

11.2.3.1 For the Right Rear Piping

- Step-1** Pull out the Indoor piping
- Step-2** Install the Indoor Unit
- Step-3** Secure the Indoor Unit
- Step-4** Insert the connection cable

11.2.3.2 For the Right and Right Bottom Piping

- Step-1** Pull out the Indoor piping
- Step-2** Install the Indoor Unit
- Step-3** Insert the connection cable
- Step-4** Secure the Indoor Unit

11.2.3.3 For the Embedded Piping

- Step-1** Replace the drain hose
- Step-2** Bend the embedded piping
 - Use a spring bender or equivalent to bend the piping so that the piping is not crushed.
- Step-3** Pull the connection cable into Indoor Unit
 - The inside and outside connection cable can be connected without removing the front grille.
- Step-4** Cut and flare the embedded piping
 - When determining the dimensions of the piping, slide the unit all the way to the left on the installation plate.
 - Refer to the section "Cutting and flaring the piping".
- Step-5** Install the Indoor Unit
- Step-6** Connect the piping
 - Please refer to "Connecting the piping" column in outdoor unit section. (Below steps are done after connecting the outdoor piping and gas-leakage confirmation.)
- Step-7** Insulate and finish the piping
 - Please refer to "Insulation of piping connection" column as mentioned in indoor/outdoor unit installation.
- Step-8** Secure the Indoor Unit

Right Rear piping

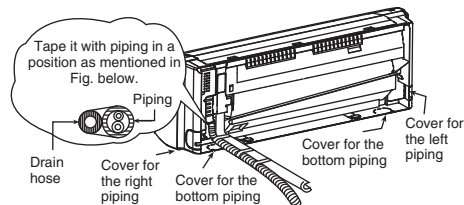

How to keep the cover

In case of the cover is cut, keep the cover at the rear of chassis as shown in the illustration for future reinstallation. (Left, right and 2 bottom covers for piping.)

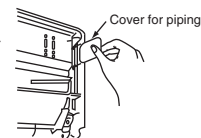

Right and Right Bottom piping

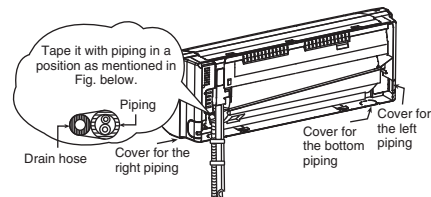

Install the indoor unit

Hook the indoor unit onto the upper portion of installation plate. (Engage the indoor unit with the upper edge of the installation plate). Ensure the hooks are properly seated on the installation plate by moving it in left and right.

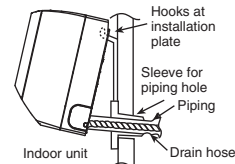

Secure the Indoor Unit

Press the lower left and right side of the unit against the installation plate until hooks engages with their slot (sound click).

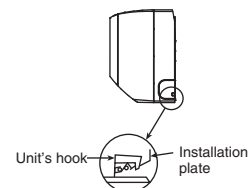

Insert the connection cable

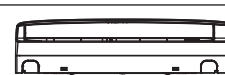
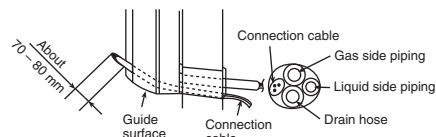

To take out the unit, push the **[PUSH]** marking at the bottom unit, and pull it slightly towards you to disengage the hooks from the unit.

(This can be used for left rear piping and left bottom piping also.)

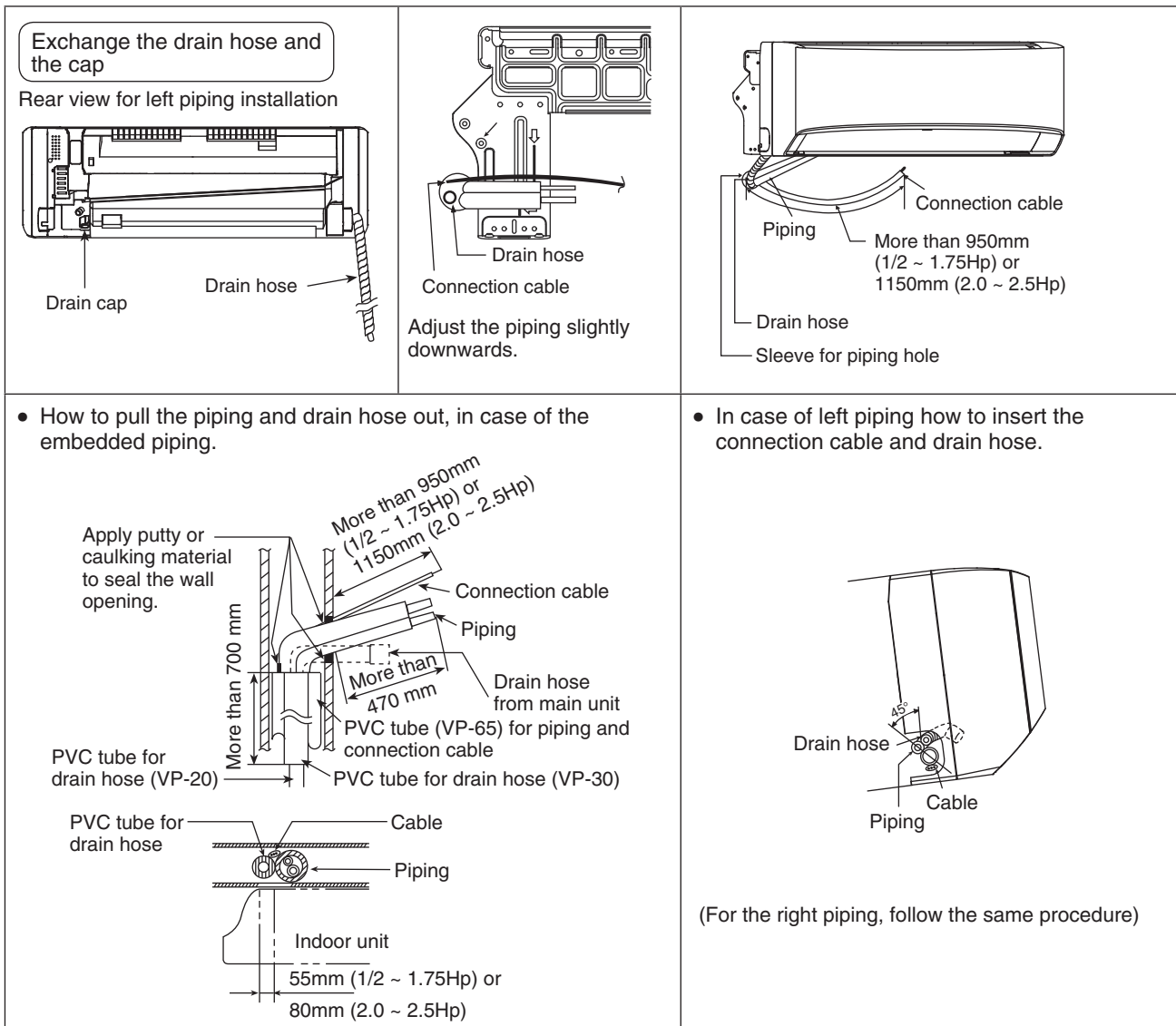

11.2.4 Connect the Cable to the Indoor Unit

- The inside and outside connection cable can be connected without removing the front grille.
- Connection cable** between indoor unit and outdoor unit shall be approved polychloroprene sheathed 4 x 1.5 mm² flexible cord, type designation 60245 IEC 57 or heavier cord. Do not use joint connection cable. Replace the wire if the existing wire (from concealed wiring, or otherwise) is too short. Allowable connection cable length of each indoor unit shall be 30 m or less.
- Bind all the indoor and outdoor connection cable with tape and route the connection cable via the escapement.
- Remove the tapes and connect the connection cable between indoor unit and outdoor unit according to the diagram below.

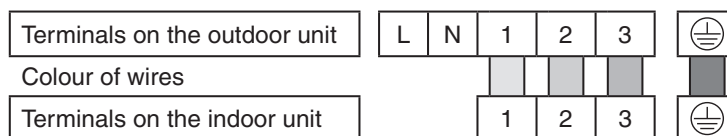

- 5 Secure the connection cable onto the control board with the holder.
 - Ensure the colour of wires of outdoor unit and the terminal Nos. are the same to the indoor's respectively.
 - Earth wire shall be Yellow/Green (Y/G) in colour and longer than other AC wires for safety reason.

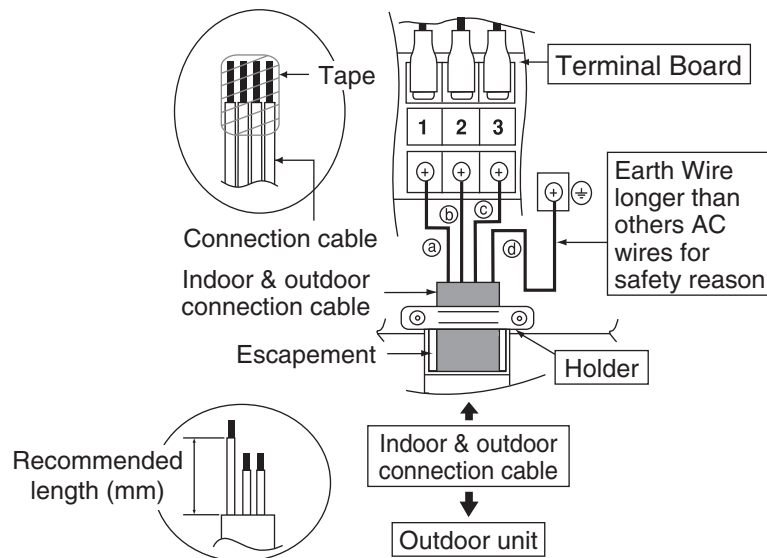

Recommended length (mm)	a	b	c	d
Recommended length (mm)	35	35	35	55

⚠ WARNING
⚡ This equipment must be properly earthed.

11.2.4.1 Wire Stripping Connecting and Requirement

<p>Wire stripping</p> <p>No loose strand when inserted</p> <p>10 ± 1 mm</p> <p>Indoor/outdoor connection terminal board</p> <p>5 mm or more (gap between wires)</p> <div style="display: flex; justify-content: space-around;"> <div style="text-align: center;"> <p>Conductor fully inserted</p> <p>ACCEPT</p> </div> <div style="text-align: center;"> <p>Conductor over inserted</p> <p>PROHIBITED</p> </div> <div style="text-align: center;"> <p>Conductor not fully inserted</p> <p>PROHIBITED</p> </div> </div>	<p>⚠ WARNING</p> <p>RISK OF FIRE</p> <p>JOINING OF WIRES MAY CAUSE OVERHEATING AND FIRE.</p>	<div style="display: flex; justify-content: space-between;"> <div style="text-align: center;"> <p>OR</p> </div> <div style="text-align: right;"> <p>⚠ Use complete wire without joining.</p> <p>⚠ Use approved socket and plug with earth pin.</p> <p>⚠ Wire connection in this area must follow to national wiring rules.</p> </div> </div> <p style="text-align: center;">⊘ Do not joint wires</p> <div style="display: flex; justify-content: space-between;"> <div style="text-align: center;"> <p>OR</p> </div> <div style="text-align: center;"> <p>OR</p> </div> </div>
---	--	--

11.3 Outdoor Unit

11.3.1 Install the Outdoor Unit

- After selecting the best location, start installation to Indoor/Outdoor Unit Installation Diagram.
 - Fix the unit on concrete or rigid frame firmly and horizontally by bolt nut ($\phi 10$ mm).
 - When installing at roof, please consider strong wind and earthquake.
Please fasten the installation stand firmly with bolt, screws or nails.

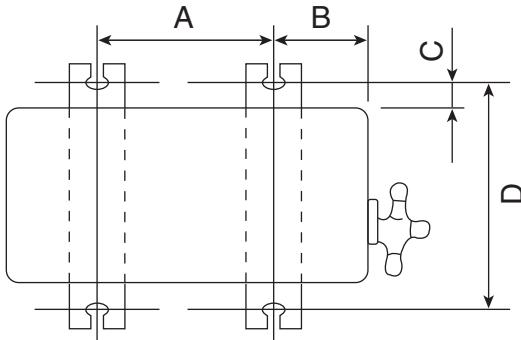

Model	A	B	C	D
TE20***, TE25***, TE35***	570 mm	105 mm	18.5 mm	320 mm
TE42***	540 mm	160 mm	18.5 mm	330 mm

11.3.2 Connect the Piping

11.3.2.1 Connecting the Piping to Indoor

Please make flare after inserting flare nut (locate at joint portion of tube assembly) onto the copper pipe.
(In case of using long piping)

Connect the piping

- Align the center of piping and sufficiently tighten the flare nut with fingers.
- Further tighten the flare nut with torque wrench in specified torque as stated in the table.

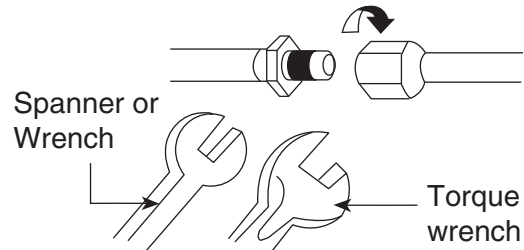

11.3.2.2 Connecting the Piping to Outdoor

Decide piping length and then cut by using pipe cutter.
Remove burrs from cut edge.

Make flare after inserting the flare nut (locate at valve) onto the copper pipe.

Align center of piping to valve and then tighten with torque wrench to the specified torque as stated in the table.

Do not overtighten, overtightening may cause gas leakage.	
Piping size	Torque
6.35 mm (1/4")	[18 N•m (1.8 kgf•m)]
9.52 mm (3/8")	[42 N•m (4.3 kgf•m)]
12.7 mm (1/2")	[55 N•m (5.6 kgf•m)]
15.88 mm (5/8")	[65 N•m (6.6 kgf•m)]
19.05 mm (3/4")	[100 N•m (10.2 kgf•m)]

11.3.2.3 Connecting the Piping to Outdoor Multi

Decide piping length and then cut by using pipe cutter.
Remove burrs from cut edge. Make flare after inserting the flare nut (locate at valve) onto the copper pipe. Align center of piping to valve and then tighten with torque wrench to the specified torque as stated in the table.

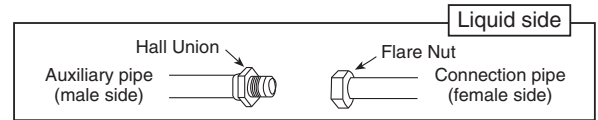

* For Gas side piping please refer table and diagram below

Outdoor Multi Combination Model			Pipe size (refer to diagram)	Gas side			
	R32 Model	R410A Model		1	2	3	4
CS-MTZ16***, CS-TZ20***, CS-TE20***, CS-TZ25***, CS-TE25***, CS-TZ35***, CS-TE35***	CU-2Z35***, CU-2Z41***, CU-2Z50***, CU-3Z52***, CU-3Z68***, CU-4Z68***, CU-4Z80***, CU-5Z90***, CU-2TZ41***, CU-2TZ50***, CU-3TZ52***	CU-2E12***, CU-2E15***, CU-2E18***, CU-3E18***, CU-3E23***, CU-4E23***, CU-4E27***, CU-5E34***, CU-2RE15***, CU-2RE18***, CU-3RE18***	1				
CS-TZ42***, CS-TE42***, CS-TZ50***, CS-TE50***	CU-2Z50***, CU-3Z52***, CU-3Z68***, CU-4Z68***, CU-4Z80***, CU-5Z90***, CU-2TZ50***, CU-3TZ52***	CU-2E18***, CU-3E18***, CU-3E23***, CU-4E23***, CU-4E27***, CU-5E34***, CU-2RE18***, CU-3RE18***	2 (CZ-MA1P)				
CS-TZ60***, CS-TE60***	CU-4Z68***, CU-4Z80***, CU-5Z90***	CU-4E23***, CU-4E27***, CU-5E34***	3 (CZ-MA2P)				
CS-TZ71***	CU-4Z80***, CU-5Z90***	CU-4E27***, CU-5E34***	4 (CZ-MA2P) & (CZ-MA3P)				

11.3.3 Evacuation of the Equipment

WHEN INSTALLING AN AIR CONDITIONER, BE SURE TO EVACUATE THE AIR INSIDE THE INDOOR UNIT AND PIPES in the following procedure.

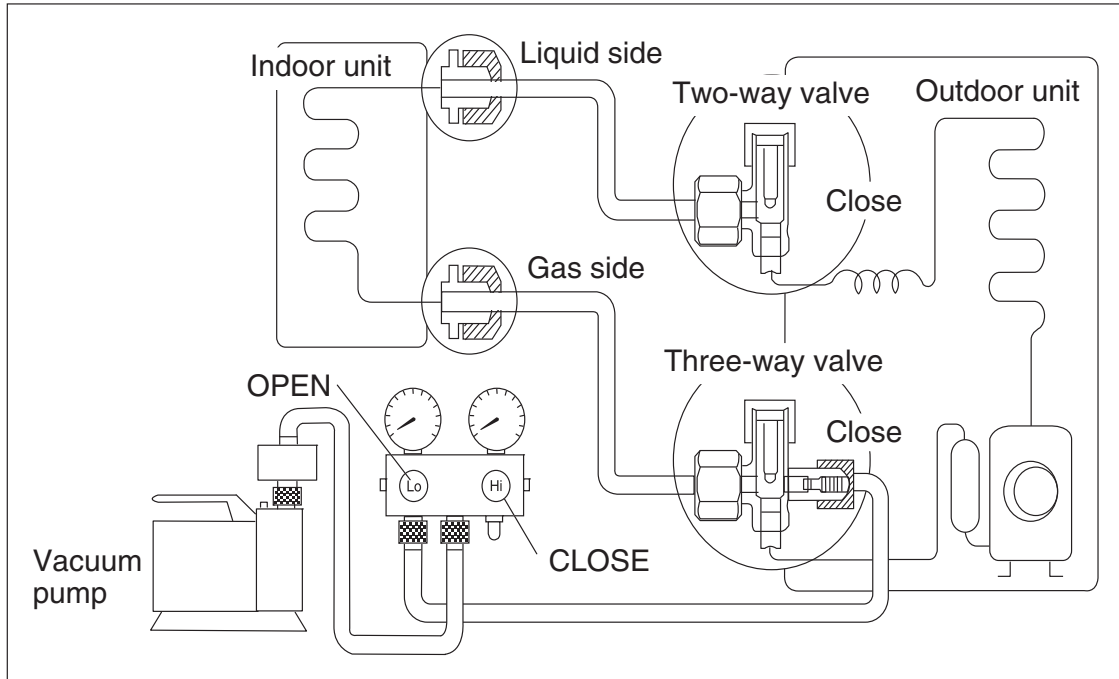

- 1 Connect a charging hose with a push pin to the Low side of a charging set and the service port of the 3-way valve.
 - o Be sure to connect the end of the charging hose with the push pin to the service port.
- 2 Connect the center hose of the charging set to a vacuum pump.
- 3 Turn on the power switch of the vacuum pump and make sure that the needle in the gauge moves from 0 cmHg (0 MPa) to -76 cmHg (-0.1 MPa). Then evacuate the air approximately ten minutes.
- 4 Close the Low side valve of the charging set and turn off the vacuum pump. Make sure that the needle in the gauge does not move after approximately five minutes.
Note: BE SURE TO TAKE THIS PROCEDURE IN ORDER TO AVOID REFRIGERENT GAS LEAKAGE.
- 5 Disconnect the charging hose from the vacuum pump and from the service port of the 3-way valve.
- 6 Tighten the service port caps of the 3-way valve at a torque of 18 N•m with a torque wrench.
- 7 Remove the valve caps of both of the 2-way valve and 3-way valve. Position both of the valves to "OPEN" using a hexagonal wrench (4 mm).
- 8 Mount valve caps onto the 2-way valve and the 3-way valve.
 - o Be sure to check for gas leakage.

- If gauge needle does not move from 0 cmHg (0 MPa) to -76 cmHg (-0.1 MPa), in step ③ above take the following measure:
 - If the leak stops when the piping connections are tightened further, continue working from step ③.
 - If the leak does not stop when the connections are retightened, repair location of leak.
 - Do not release refrigerant during piping work for installation and reinstallation.
 - Take care of the liquid refrigerant, it may cause frostbite.

11.3.4 Connect the Cable to the Outdoor Unit

- 1 Remove the control board cover from the unit by loosening the screw.
- 2 Cable connection to the power supply through Isolating Devices (Disconnecting means).
 - Connect approved type polychloroprene sheathed **power supply cord** 3 x 1.5 mm² (3/4 ~ 1.75HP), 3 x 2.5 mm² (2.0 ~ 2.5HP) type designation 60245 IEC 57 or heavier cord to the terminal board, and connect the others end of the cord to Isolating Devices (Disconnecting means).
 - Do not use joint power supply cord. Replace the wire if the existing wire (from concealed wiring, or otherwise) is too short.
 - In unavoidable case, joining of power supply cord between isolating devices and terminal board of air conditioner shall be done by using approved socket and plug with earth pin rated 15/16A (3/4 ~ 1.75HP) or 16A (2.0HP) or 20A (2.5HP). Wiring work to both socket and plug must follow to national wiring standard.
- 3 **Connection cable** between indoor unit and outdoor unit shall be approved polychloroprene sheathed 4 x 1.5 mm² flexible cord, type designation 60245 IEC 57 or heavier cord. Do not use joint connection cable. Replace the wire if the existing wire (from concealed wiring, or otherwise) is too short. Allowable connection cable length of each indoor unit shall be 30 m or less.
- 4 Connect the power supply cord and connection cable between indoor unit and outdoor unit according to the diagram below.

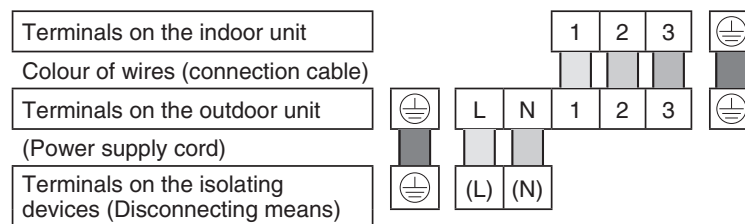

- 5 Secure the power supply cord and connection cable onto the control board with the holder.
- 6 Attach the control board cover back to the original position with screw.
- 7 For wire stripping and connection requirement, refer to instruction 12.2.4 of indoor unit.

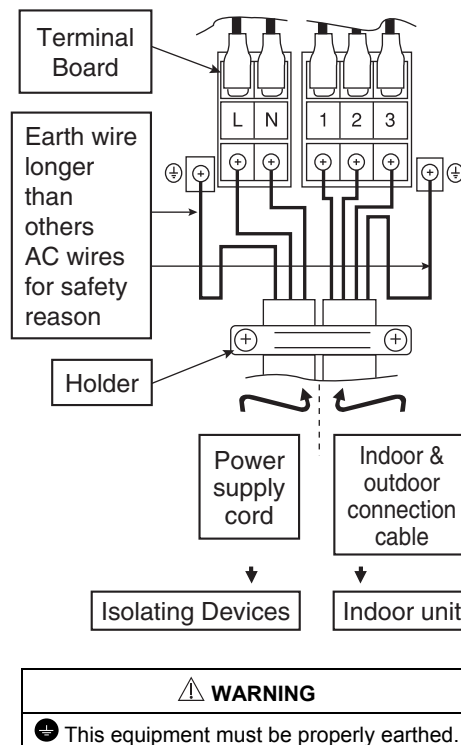

Note

- Isolating Devices (Disconnecting means) should have minimum 3.0 mm contact gap.
- Earth wire shall be Yellow/Green (Y/G) in colour and longer than other AC wires for safety reason.
- Always ensure all above connections compliant with national wire rules.

11.3.5 Piping Insulation

- 1 Please carry out insulation at pipe connection portion as mentioned in Indoor/Outdoor Unit Installation Diagram. Please wrap the insulated piping end to prevent water from going inside the piping.
- 2 If drain hose or connecting piping is in the room (where dew may form), please increase the insulation by using POLY-E FOAM with thickness 6 mm or above.

11.3.5.1 Cutting and Flaring the Piping

- 1 Please cut using pipe cutter and then remove the burrs.
- 2 Remove the burrs by using reamer. If burrs is not removed, gas leakage may be caused. Turn the piping end down to avoid the metal powder entering the pipe.
- 3 Please make flare after inserting the flare nut onto the copper pipes.

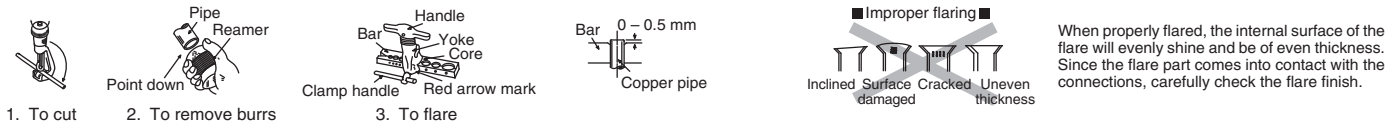

11.3.6 How to Take Out Front Grille

Please follow the steps below to take out front grille if necessary such as when servicing.

- 1 Set the vertical airflow direction louvers to the horizontal position.
- 2 Remove the 2 caps (1/2 ~ 1.75HP) or 3 caps (2.0 ~ 2.5HP) on the front grille as shown in the illustration at right, and then remove the 3 (1/2 ~ 1.75HP) or 4 (2.0 ~ 2.5HP) mounting screws.
- 3 Pull the lower section of the front grille towards you to remove the front grille.

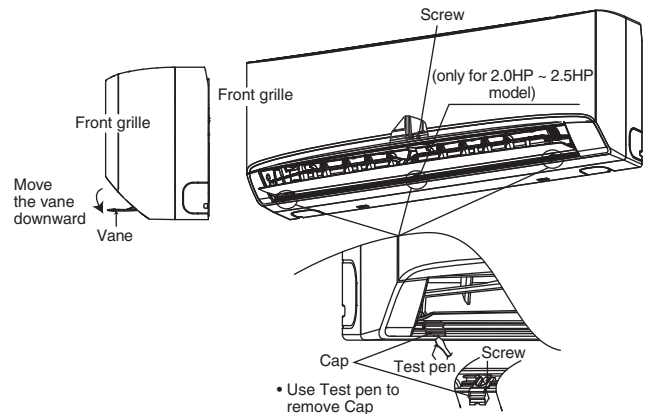

When reinstalling the front grille, first set the vertical airflow direction louver to the horizontal position and then carry out above steps 2 - 3 in the reverse order.

11.3.7 Disposal of Outdoor Unit Drain Water

- If a drain elbow is used, the unit should be placed on a stand which is taller than 3 cm.
- If the unit is used in an area where temperature falls below 0°C for 2 or 3 days in succession, it is recommended not to use a drain elbow, for the drain water freezes and the fan will not rotate.

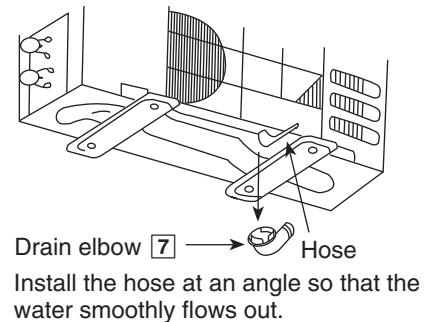

11.3.8 Check the Drainage

- Open front panel and remove air filters. (Drainage checking can be carried out without removing the front grille.)
- Pour a glass of water into the drain tray-styrofoam.
- Ensure that water flows out from drain hose of the indoor unit.

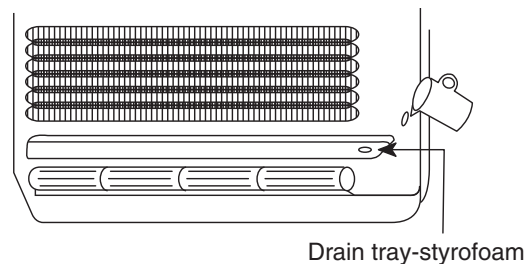

11.3.9 Evaluation of the Performance

- Operate the unit at cooling/heating operation mode for fifteen minutes or more.
- Measure the temperature of the intake and discharge air.
- Ensure the difference between the intake temperature and the discharge is more than 8°C during Cooling operation or more than 14°C during Heating operation.

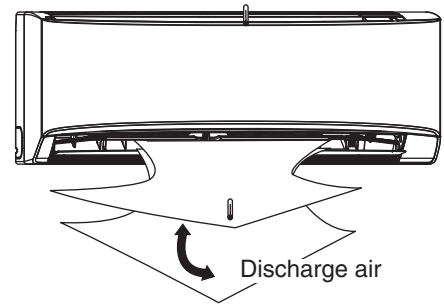

11.3.10 Installation of Air Purifying Filter

- 1 Open the front panel.
- 2 Remove the air filters.
- 3 Put the Air purifying filter into place as shown in illustration at right.

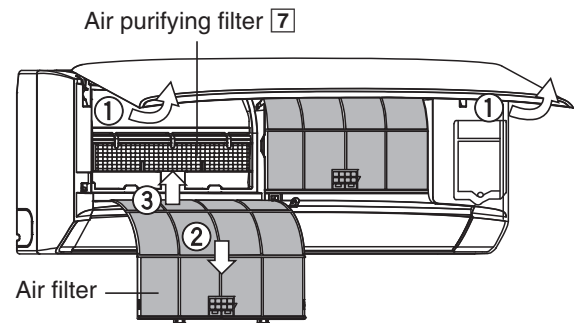

12. Operation Control

12.1 Basic Function

Inverter control, which equipped with a microcomputer in determining the most suitable operating mode as time passes, automatically adjusts output power for maximum comfort always. In order to achieve the suitable operating mode, the microcomputer maintains the set temperature by measuring the temperature of the environment and performing temperature shifting. The compressor at outdoor unit is operating following the frequency instructed by the microcomputer at indoor unit that judging the condition according to internal setting temperature and intake air temperature.

12.1.1 Internal Setting Temperature

Once the operation starts, remote control setting temperature will be taken as base value for temperature shifting processes. These shifting processes are depending on the air conditioner settings and the operation environment. The final shifted value will be used as internal setting temperature and it is updated continuously whenever the electrical power is supplied to the unit.

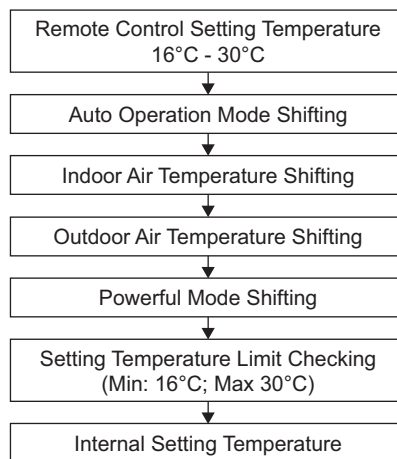

12.1.2 Cooling Operation

12.1.2.1 Thermostat control

- Compressor is OFF when Intake Air Temperature - Internal Setting Temperature < -1.5°C continue for 3 minutes.
- When compressor is OFF (Thermostat OFF) and AUTO FAN is set, the fan will stop periodically.
- Compressor is ON after waiting for 3 minutes, if the Intake Air Temperature - Internal Setting Temperature > Compressor OFF point.

12.1.3 Soft Dry Operation

12.1.3.1 Thermostat control

- Compressor is OFF when Intake Air Temperature - Internal Setting Temperature < -2.0°C continue for 3 minutes.
- When compressor is OFF (Thermostat OFF) and AUTO FAN is set, the fan will stop periodically.
- Compressor is ON after waiting for 3 minutes, if the Intake Air Temperature - Internal Setting Temperature > Compressor OFF point.

12.1.4 Heating Operation

12.1.4.1 Thermostat control

- Compressor is OFF when Intake Air Temperature - Internal Setting Temperature > +2.0°C continue for 3 minutes.
- Compressor is ON after waiting for 3 minutes, if the Intake Air Temperature - Internal Setting Temperature < Compressor OFF point.

12.1.5 Automatic Operation

- This mode can be set using remote control and the operation is decided by remote control setting temperature, remote control operation mode and indoor intake air temperature.
- During operation mode judgment, indoor fan motor (with speed of Lo-) is running for 30 seconds to detect the indoor intake air temperature.
- Every 10 minutes, the indoor temperature is judged.
- For the 1st judgment
 - If indoor intake temperature - remote control setting temperature $\geq 2^{\circ}\text{C}$, COOL mode is decided.
 - If $-2^{\circ}\text{C} \leq$ indoor intake temperature - remote control setting temperature $< 2^{\circ}\text{C}$, DRY mode is decided.
 - If indoor intake temperature - remote control setting temperature $< -2^{\circ}\text{C}$, HEAT mode is decided.

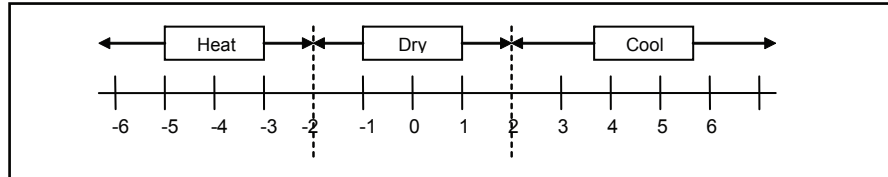

- For the 2nd judgment onwards
 - If indoor intake temperature - remote control setting temperature $\geq 3^{\circ}\text{C}$, if previous operate in DRY mode, then continue in DRY mode. otherwise COOL mode is decided.
 - If $-2^{\circ}\text{C} \leq$ indoor intake temperature - remote control setting temperature $< 3^{\circ}\text{C}$, maintain with previous mode.
 - If indoor intake temperature - remote control setting temperature $< -2^{\circ}\text{C}$, HEAT mode is decided.

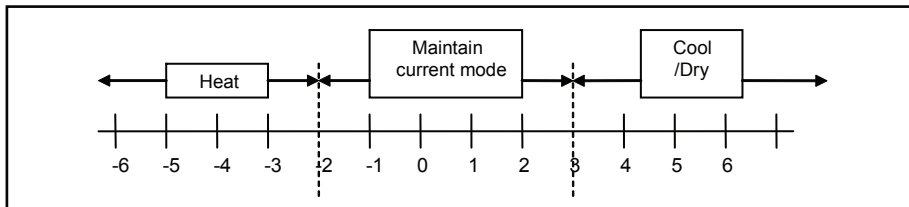

12.2 Indoor Fan Motor Operation

12.2.1 Basic Rotation Speed (rpm)

A. Basic Rotation Speed (rpm)

i. Manual Fan Speed

[Cooling, Dry]

- Fan motor's number of rotation is determined according to remote control setting.

Remote control	○	○	○	○	○
Tab	Hi	Me	Me-	Lo	QLo

[Heating]

- Fan motor's number of rotation is determined according to remote control setting.

Remote control	○	○	○	○	○
Tab	SHi	Me	Me-	Lo	QLo

ii Auto Fan Speed

[Cooling, Dry]

- According to room temperature and setting temperature, indoor fan speed is determined automatically.
- When set temperature is not achieved, the indoor fan will operate according to pattern below.

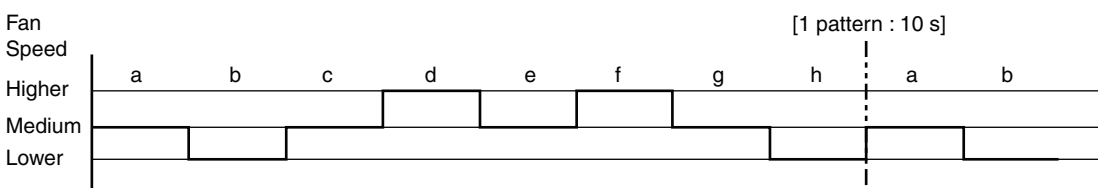

- When set temperature achieved, the indoor fan speed will be fixed. When thermostat off, the fan stop periodically.

[Heating]

- According to indoor pipe temperature, automatic heating fan speed is determined as follows.

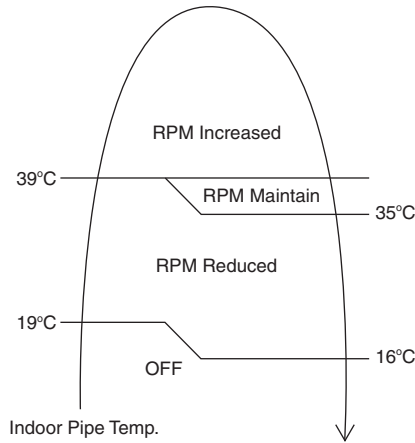

B. Feedback control

- Immediately after the fan motor started, feedback control is performed once every second.
- During fan motor on, if fan motor feedback ≥ 2550 rpm or < 50 rpm continue for 10 seconds, then fan motor error counter increase, fan motor is then stop and restart. If the fan motor counter becomes 7 times, then H19 - fan motor error is detected. Operation stops and cannot on back.

12.3 Outdoor Fan Motor Operation

Outdoor fan motor is operated with one fan speed only. It starts when compressor starts operation and it stops 30 seconds after compressor stops operation.

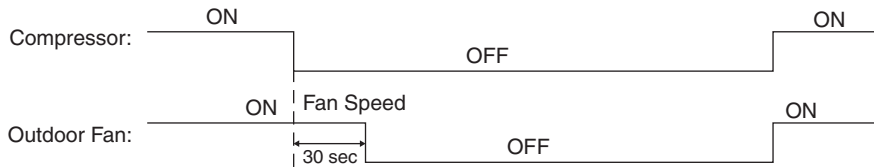

- During cooling operation, and outdoor ambient temperature is below 8°C , outdoor fan speed will be controlled according to outdoor piping temperature as following:

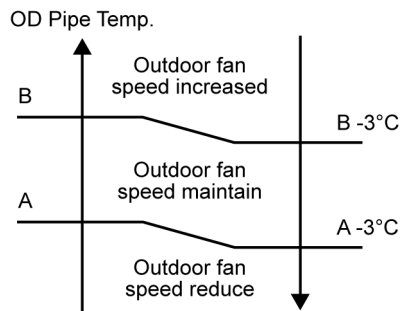

	OD Pipe Temperature
A	26°C
B	33°C

- During above condition, when indoor heat exchanger temperature is below 5°C , the outdoor fan will stop according to outdoor piping temperature as following:

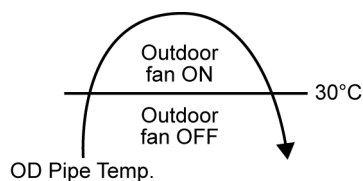

12.4 Airflow Direction

- There are two types of airflow, vertical airflow (directed by horizontal vane) and horizontal airflow (directed by vertical vanes).
- Control of airflow direction can be automatic (angles of direction is determined by operation mode, heat exchanger temperature and intake air temperature) and manual (angles of direction can be adjusted using remote control).

12.4.1 Vertical Airflow

Operation Mode	Airflow Direction	Inner Vane Angle (°)					Outer Vane Angle (°)					
		1	2	3	4	5	1	2	3	4	5	
Cooling	Auto	10 ~ 45					20 ~ 56					
	Manual	10	15	20	30	45	20	32	44	50	56	
Soft Dry	Auto	10 ~ 45					20 ~ 56					
	Manual	10	15	20	30	45	20	32	44	50	56	
Heating	Auto	A	10					20				
		B	30					65				
		C	20					44				
	Manual	8	12	20	40	50	28	36	44	65	72	

- 1 Automatic vertical airflow direction can be set using remote control; the vane swings up and down within the angles as stated above. For heating mode operation, the angle of the vane depends on the indoor heat exchanger temperature as Figure 1 below. It does not swing during fan motor stop. When the air conditioner is stopped using remote control, the vane will shift to close position.
- 2 Manual vertical airflow direction can be set using remote control; the angles of the vane are as stated above and the positions of the vane are as Figure 2 below. When the air conditioner is stopped using remote control, the vane will shift to close position.

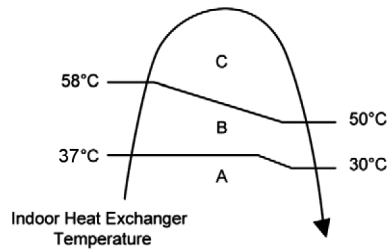
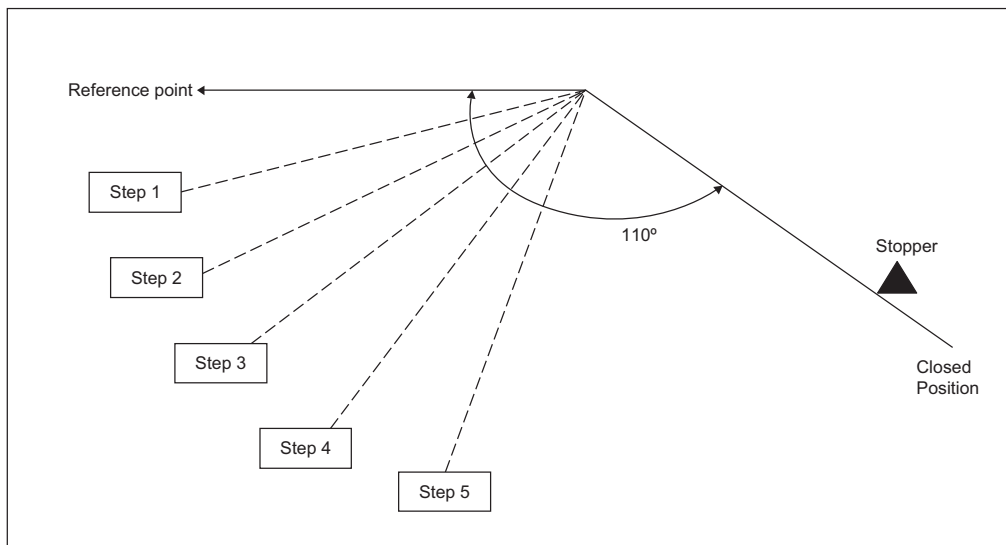

Figure 1

Side View (Inner Vane)



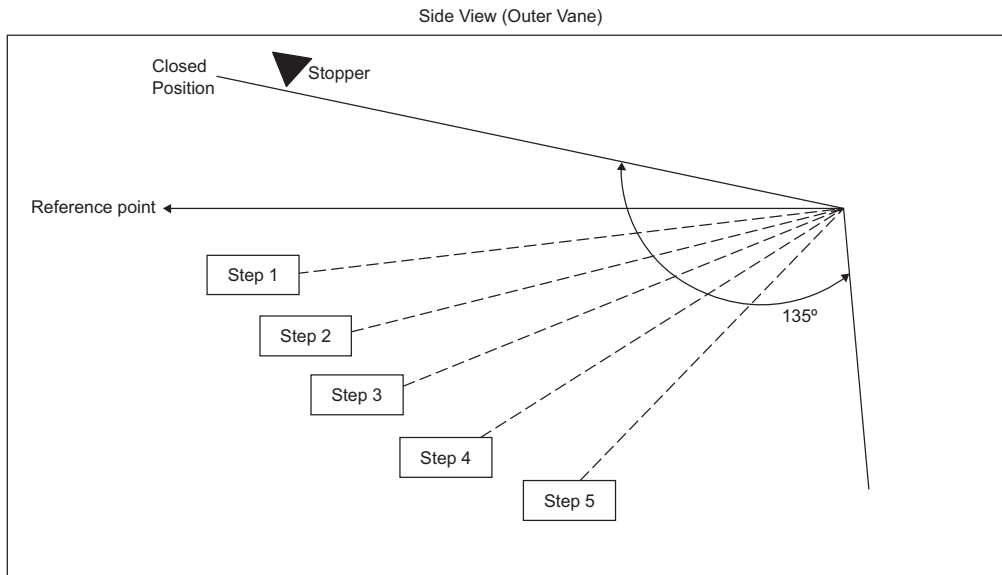

Figure 2

* The horizontal vane angle tolerance is within +/- 5 degree.

12.4.2 Horizontal Airflow

- The horizontal airflow direction louver can be adjusted manually by hand.

12.5 Timer Control

- There are 2 sets of ON and OFF timer available to turn the unit ON or OFF at different preset time.
- If more than one timer had been set, the upcoming timer will be displayed and will activate in sequence.

12.5.1 ON Timer Control

- ON timer 1 and ON timer 2 can be set using remote control, the unit with timer set will start operate earlier than the setting time.
This is to provide a comfortable environment when reaching the set ON time.
- 60 minutes before the set time, indoor (at fan speed of Lo-) and outdoor fan motor start operate for 30 seconds to determine the indoor intake air temperature and outdoor air temperature in order to judge the operation starting time.
- From the above judgment, the decided operation will start operate earlier than the set time as shown below.

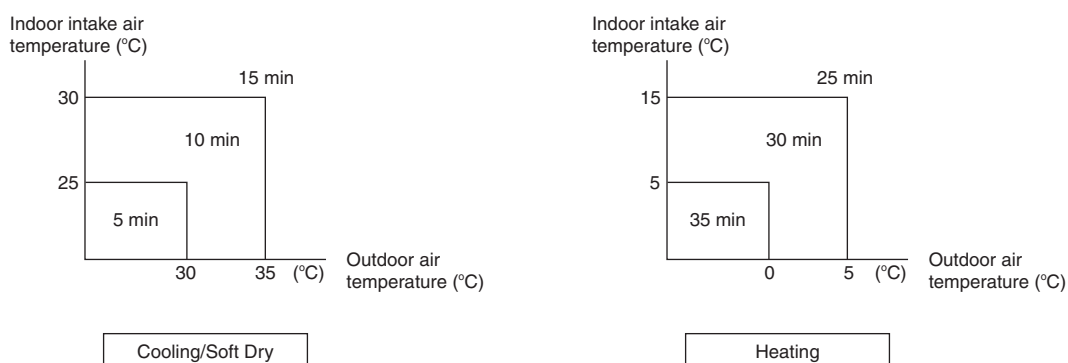

12.5.2 OFF Timer Control

OFF timer 1 and OFF timer 2 can be set using remote control, the unit with timer set will stop operate at set time.

12.6 Sleep Mode Operation

SLEEP To maximise comfort while sleeping



- This operation provides you with a comfortable environment while sleeping. It will automatically adjust the sleep pattern temperature during the activation period.
- The indoor unit indicator will dim when this operation is activated. This is not applicable if the indicator brightness has been manually dimmed.
- This operation is incorporated with the activation timer (0.5, 1, 2, 3, 4, 5, 6, 7, 8 or 9 hours).
- This operation can be set together with single timer or twin timer. Sleep operation has the priority over OFF timer.
- This operation can be cancelled by pressing the respective button when the sleep timer reaches 0.0h.

12.7 Auto Restart Control

- When the power supply is cut off during the operation of air conditioner, the compressor will re-operate within three to four minutes (there are 10 patterns between 2 minutes 58 seconds and 3 minutes 52 seconds to be selected randomly) after power supply resumes.
- This type of control is not applicable during ON/OFF Timer setting.
- This control can be omitted by open the circuit of JP1 at indoor unit printed circuit board.

12.8 Indication Panel

LED	POWER	TIMER
Color	Green	Orange
Light ON	Operation ON	Timer Setting ON
Light OFF	Operation OFF	Timer Setting OFF

Note:

- If POWER LED is blinking, the possible operation of the unit are Hot Start, during Deice operation, operation mode judgment, or ON timer sampling.
- If Timer LED is blinking, there is an abnormality operation occurs.

12.9 Quiet Operation (Cooling Mode/Cooling Area of Dry Mode)

A. Purpose

To provide quiet cooling operation compare to normal operation.

B. Control condition

- Quiet operation start condition
 - When "POWERFUL/QUIET" button at remote control is pressed twice.
- Quiet operation stop condition
 - When one of the following conditions is satisfied, quiet operation stops:
 - POWERFUL/QUIET button is pressed again.
 - Stop by OFF/ON switch.
 - Timer "off" activates.
 - When quiet operation is stopped, operation is shifted to normal operation with previous setting.
 - When fan speed is changed, quiet operation is shifted to quiet operation of the new fan speed.
 - When operation mode is changed, quiet operation is shifted to quiet operation of the new mode.
 - During quiet operation, if timer "on" activates, quiet operation maintains.
 - After off, when on back, quiet operation is not memorized.

C. Control contents

- Fan speed is changed from normal setting to quiet setting of respective fan speed.
- Fan speed for quiet operation is reduced from setting fan speed.

12.10 Quiet Operation (Heating)

A. Purpose

To provide quiet heating operation compare to normal operation.

B. Control condition

- a. Quiet operation start condition
 - o When "POWERFUL/QUIET" button at remote control is pressed.
- b. Quiet operation stop condition
 - 1 When one of the following conditions is satisfied, quiet operation stops:
 - a. POWERFUL/QUIET button is pressed again.
 - b. Stop by OFF/ON switch.
 - c. Timer "off" activates.
 - 2 When quiet operation is stopped, operation is shifted to normal operation with previous setting.
 - 3 When fan speed is changed, quiet operation is shifted to quiet operation of the new fan speed.
 - 4 When operation mode is changed, quiet operation is shifted to quiet operation of the new mode.
 - 5 During quiet operation, if timer "on" activates, quiet operation maintains.
 - 6 After off, when on back, quiet operation is not memorized.

C. Control contents

- a. Fan Speed manual
 - 1 Fan speed is changed from normal setting to quiet setting of respective fan speed.
 - 2 Fan speed for quiet operation is reduced from setting fan speed.
- b. Fan Speed Auto
 - 1 Indoor FM RPM depends on pipe temp sensor of indoor heat exchanger.

12.11 Powerful Mode Operation

- When the powerful mode is selected, the internal setting temperature will shift lower up to 2°C (for Cooling/Soft Dry) or higher up to 3.5°C (for Heating) than remote control setting temperature for 20 minutes to achieve the setting temperature quickly.

13. Operation Control (For Multi Split Connection)

During multi split connection, indoor unit's operation controls are same with single split connection unless specified in this chapter.

13.1 Cooling operation

13.1.1 Thermostat control

- Capability supply to indoor unit is OFF (Expansion valve closed) when Intake Air Temperature — Internal setting temperature $< -2.0^{\circ}\text{C}$.
- Capability resume supply to indoor unit after waiting for 3 minutes, if the Intake Air temperature — Internal setting temperature $>$ Capability supply OFF point.

13.2 Soft Dry Operation

13.2.1 Thermostat control

- Capability supply to indoor unit is OFF (Expansion valve closed) when Intake Air Temperature — Internal setting temperature $< -3.0^{\circ}\text{C}$.
- Capability resume to indoor unit after waiting for 3 minutes, if the Intake Air temperature — Internal setting temperature $>$ Capability supply OFF point.

13.3 Heating Operation

13.3.1 Thermostat control

- Capability supply to indoor unit is OFF (Expansion valve closed) when Intake Air Temperature — Internal setting temperature $> +1.0^{\circ}\text{C}$.
- During this condition, the indoor fan is stopped if compressor is ON.
- Capability resume supply to indoor unit after waiting for 3 minutes, if the Intake Air Temperature — Internal setting temperature $<$ Capability supply OFF point.

13.3.2 Temperature Sampling Control

- Temperature sampling is controlled by outdoor unit where room temperature for all power supply ON indoor unit could be obtained.
- When capability supply to the indoor unit is OFF and the compressor is ON, the indoor fan motor is stopped. During this condition, 15 seconds after sampling signal from outdoor unit is received, the indoor fan start operation at low fan speed.
- However, within first 4 minutes of capability stopped supply to the indoor unit, even sampling signal is received, the sampling control is cancelled.

13.4 Automatic Operation

- This mode can be set using remote control and the operation is decided by remote control setting temperature, remote control operation mode, indoor intake and outdoor air temperature.
- During operation mode judgment, indoor fan motor (with speed of -Lo) and outdoor fan motor are running for 30 seconds to detect the indoor intake and outdoor air temperature. The operation mode is decided based on below chart.

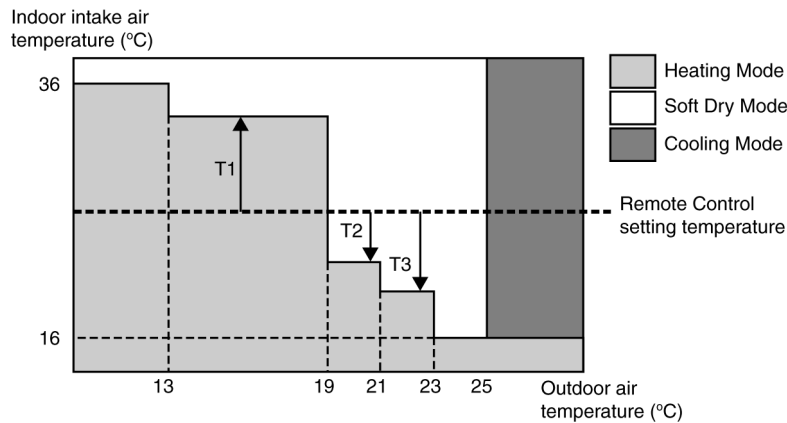

- Every 180 minutes, the indoor and outdoor temperature is judge. Based on remote control setting temperature, the value of T1 will increase up to 10°C, T2 will decrease by 3°C and T3 will decrease up to 8°C.

13.5 Indoor Fan Motor Operation

13.5.1 Residual Heat Removal Control

- To prevent high pressure at indoor unit, when heating mode thermostat-off condition or power supply OFF, indoor fan continue to operate at controlled fan speed for maximum 30 seconds then stop.

13.6 Powerful Mode Operation

- When the power mode is selected, the internal setting temperature will shift lower up to 4°C for Cooling/Soft Dry or higher up to 6°C for heating than remote control setting temperature, the powerful operation continue until user cancel the Powerful operation by pressing powerful button again.

13.7 Auto Restart Control

- When the power supply is cut off during the operation of air conditioner, the compressor will re-operate between three to four minutes (10 patterns to be selected randomly) after power resume.
- During multi split connection, Indoor unit will resume previous mode, include unit standby mode.

13.8 Indication Panel

LED	POWER	TIMER
Color	White	White
Light ON	Operation ON	Timer Setting ON
Light OFF	Operation OFF	Timer Setting OFF

Note:

- If POWER LED is blinking (0.5 seconds ON, 0.5 second OFF), the possible operation of the unit are during Indoor Residual Heat Removal, Hot Start, during Deice operation, operation mode judgment, or ON timer sampling.
- If POWER LED is blinking (2.5 seconds ON, 0.5 second OFF), the unit is in standby mode.
- If TIMER LED is blinking, there is an abnormality operation occurs.

14. Protection Control

14.1 Protection Control for All Operations

14.1.1 Restart Control (Time Delay Safety Control)

- The Compressor will not turn on within 3 minutes from the moment operation stops, although the unit is turned on again by pressing OFF/ON button at remote control within this period.
- This control is not applicable if the power supply is cut off and on again.
- This phenomenon is to balance the pressure inside the refrigerant cycle.

14.1.2 Total Running Current

- 1 When the outdoor unit total running current (AC) exceeds X value, the frequency instructed for compressor operation will be decreased.
- 2 If the running current does not exceed X value for 5 seconds, the frequency instructed will be increased.
- 3 However, if total outdoor unit running current exceeds Y value, compressor will be stopped immediately for 3 minutes.

Model	TE20TKE		TE25TKE		TE35TKE		TE42TKE	
	X (A)	Y (A)	X (A)	Y (A)	X (A)	Y (A)	X (A)	Y (A)
Cooling / Soft Dry (A)	3.78	15.02	5.21	15.02	6.97	15.02	7.94	15.02
Cooling / Soft Dry (B)	3.30		4.73		6.45		7.42	
Cooling / Soft Dry (C)	3.30		4.73		6.45		7.42	
Heating	4.17		4.65		5.92		9.13	

- 4 The first 30 minutes of cooling operation, (A) will be applied.

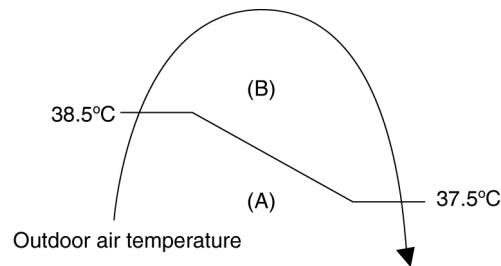

14.1.3 IPM (Power transistor) Prevention Control

- Overheating Prevention Control
 - 1 When the IPM temperature rises to 120°C, compressor operation will stop immediately.
 - 2 Compressor operation restarts after 3 minutes the temperature decreases to 110°C.
 - 3 If this condition repeats continuously 4 times within 20 minutes, timer LED will be blinking ("F96" is indicated).
- DC Peak Current Control
 - 1 When electric current to IPM exceeds set value of $16.0 \pm 2.0A$, the compressor will stop operate. Then, operation will restart after 3 minutes.
 - 2 If the set value is exceeded again more than 30 seconds after the compressor starts, the operation will restart after 1 minute.
 - 3 If the set value exceeded again within 30 seconds after the compressor starts, the operation will restart after 1 minute. If this condition repeats continuously for 7 times, all indoor and outdoor relays will be cut off, timer LED will be blinking ("F99" is indicated).

14.1.4 Compressor Overheating Prevention Control

- Instructed frequency for compressor operation will be regulated by compressor temperature. The changes of frequency are as below.
- If compressor temperature exceeds 103°C, compressor will be stopped, occurs 4 times per 20 minutes, timer LED will be blinking. ("F97" is indicated.)

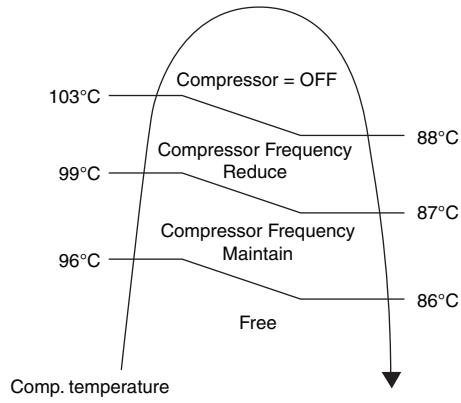

14.1.5 Low Pressure Prevention Control (Gas Leakage Detection)

- Control start conditions
 - For 5 minutes, the compressor continuously operates and outdoor total current is between 0.75A and 0.95A.
 - During Cooling and Soft Dry operations:
Indoor suction temperature - indoor piping temperature is below 4°C.
 - During Heating operations :
Indoor piping temperature - indoor suction is under 5°C.
- Control contents
 - Compressor stops (and restart after 3 minutes).
 - If the conditions above happen 2 times within 20 minutes, the unit will:
 - Stop operation
 - Timer LED blinks and “F91” indicated.

14.1.6 Low Frequency Protection Control 1

- When the compressor operate at frequency lower than 24 Hz continued for 20 minutes, the operation frequency will be changed to 23 Hz for 2 minutes.

14.1.7 Low Frequency Protection Control 2

- When all the below conditions comply, the compressor frequency will change to lower frequency.

Temperature, T, for:	Cooling/Soft Dry	Heating
Indoor intake air (°C)	$T < 14$ or $T \geq 30$	$T < 14$ or $T \geq 28$
Outdoor air (°C)	$T < 13$ or $T \geq 38$	$T < 4$ or $T \geq 24$
Indoor heat exchanger (°C)	$T < 30$	$T \geq 0$

14.2 Protection Control for Cooling & Soft Dry Operation

14.2.1 Outdoor Air Temperature Control

- The compressor operating frequency is regulated in accordance to the outdoor air temperature as shown in the diagram below.
- This control will begin 1 minute after the compressor starts.
- Compressor frequency will adjust base on outdoor air temperature.

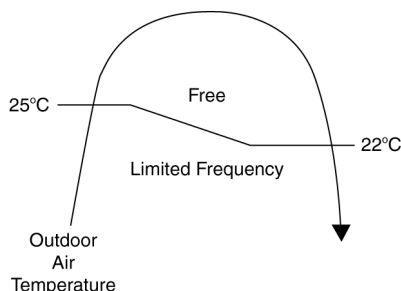

- The compressor will be stopped to avoid compressor overloading.

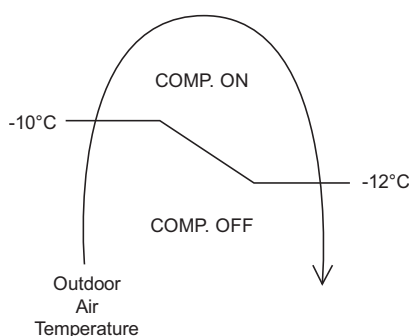

14.2.2 Cooling Overload Control

- Detects the Outdoor pipe temperature and carry out below restriction/limitation (Limit the compressor Operation frequency).
- The compressor stop if outdoor pipe temperature exceeds 60°C.
- If the compressor stops 4 times in 20 minutes, Timer LED blinking (F95 indicated: outdoor high pressure rise protection).

14.2.3 Freeze Prevention Control 1

- When indoor heat exchanger temperature is lower than 0°C continuously for 6 minutes, compressor will stop operating.
- Compressor will resume its operation 3 minutes after the indoor heat exchanger is higher than 5°C.
- At the same time, indoor fan speed will be higher than during its normal operation.
- If indoor heat exchanger temperature is higher than 5°C for 5 minutes, the fan speed will return to its normal operation.

14.2.4 Freeze Prevention Control 2

- Control start conditions
 - During Cooling operation and soft dry operation
 - During thermo OFF condition, indoor intake temperature is less than 10°C or
 - Compressor stops for freeze prevention control
 - Either one of the conditions above occurs 5 times in 60 minutes.
- Control contents
 - Operation stops
 - Timer LED blinks and “H99” indicated

14.2.5 Dew Prevention Control 1

- To prevent dew formation at indoor unit discharge area.
- This control will be activated if:
 - Outdoor air temperature and Indoor pipe temperature judgment by microcontroller is fulfilled.
 - When Cooling or Dry mode is operated more than 20 minutes or more.
- This control stopped if:
 - Compressor stopped.
 - Remote control setting changed (fan speed / temperature).
 - Outdoor air temperature and indoor intake temperature changed.
- Fan speed will be adjusted accordingly in this control.

14.2.6 Odor Cut Control

- To reduce the odor released from the unit.
 - Start Condition
 - AUTO FAN Speed is selected during COOL or DRY operation.
 - During freeze prevention control and timer preliminary operation, this control is not applicable.
 - Control content
 - Depends on compressor conditions:
 1. Compressor OFF → Compressor ON.
The indoor unit fan stops temporarily and then starts to blow at minimum airflow for 30 seconds.
 2. Compressor ON → Compressor OFF.
The indoor unit fan stops for 90 seconds and then blows at minimum airflow for 20 seconds.

14.3 Protection Control for Heating Operation

14.3.1 Intake Air Temperature Control

Compressor will operate at limited freq., if indoor intake air temperature is 30°C or above.

14.3.2 Outdoor Air Temperature Control

- The Max current value is regulated when the outdoor air temperature rise above 14°C in order to avoid compressor overloading.

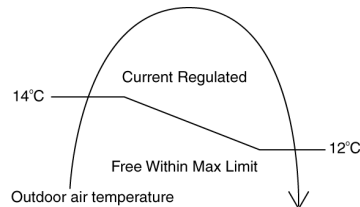

14.3.3 Overload Protection Control

- The compressor operating frequency is regulated in accordance to indoor heat exchanger temperature as shown below.
- If the heat exchanger temperature exceeds 60°C, compressor will stop.

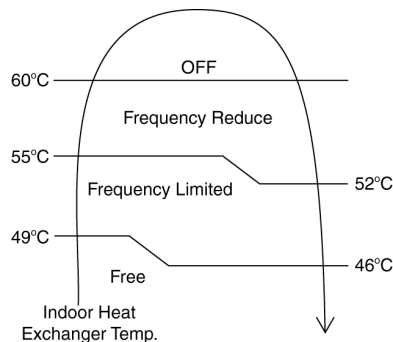

14.3.4 Low Temperature Compressor Oil Return Control

- In heating operation, if the outdoor temperature falls below -10°C when compressor starts, the compressor frequency will be regulated up to 600 seconds.

14.3.5 Cold Draught Prevention Control

- When indoor pipe temperature is low, cold draught operation starts where indoor fan speed will be reduced.

14.3.6 Deice Operation

- When outdoor pipe temperature and outdoor air temperature is low, deice operation start where indoor fan motor and outdoor fan motor stop and operation LED blinks.

14.3.7 Low Pressure Protection Control

- During low ambient heating operation, if the pipe temperature drops below -24°C , the max frequency will be reduced and limited.
- If it does not rises after 3 minutes, the compressor will stop.
- The compressor will start again if the pipe temperature rises above -20°C .

15. Servicing Mode

15.1 Auto OFF/ON Button

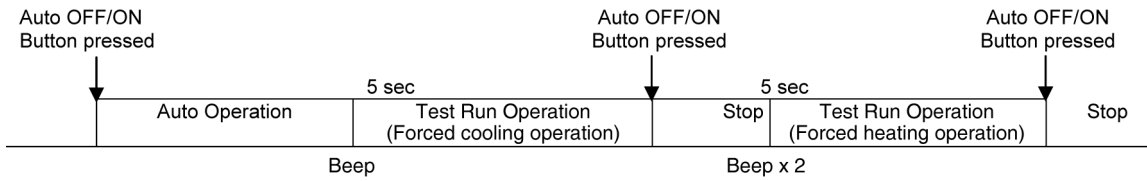

1 AUTO OPERATION MODE

The Auto operation will be activated immediately once the Auto OFF/ON button is pressed. This operation can be used to operate air conditioner with limited function if remote control is misplaced or malfunction.

2 TEST RUN OPERATION (FOR PUMP DOWN/SERVICING PURPOSE)

The Test Run operation will be activated if the Auto OFF/ON button is pressed continuously for more than 5 seconds. A “beep” sound will heard at the fifth seconds, in order to identify the starting of Test Run operation (Forced cooling operation). Within 5 minutes after Forced cooling operation start, the Auto OFF/ON button is pressed for more than 5 seconds. A 2 “beep” sounds will heard at the fifth seconds, in order to identify the starting of Forced heating operation.

The Auto OFF/ON button may be used together with remote control to set / change the advance setting of air conditioner operation.

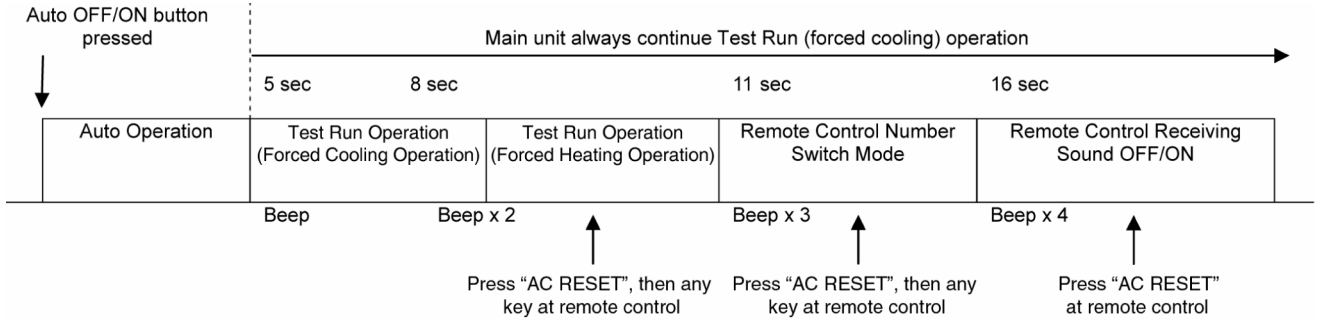

3 REMOTE CONTROL NUMBER SWITCH MODE

The Remote Control Number Switch Mode will be activated if the Auto OFF/ON button is pressed continuously for more than 11 seconds (3 “beep” sounds will occur at 11th seconds to identify the Remote Control Number Switch Mode is in standby condition) and press “AC RESET” button and then press any button at remote control to transmit and store the desired transmission code to the EEPROM.

There are 4 types of remote control transmission code could be selected and stored in EEPROM of indoor unit. The indoor unit will only operate when received signal with same transmission code from remote control. This could prevent signal interference when there are 2 or more indoor units installed nearby together. To change remote control transmission code, short or open jumpers at the remote control printed circuit board.

Remote Control Printed Circuit Board		
Jumper A (J-A)	Jumper B (J-B)	Remote Control No.
Short	Open	A (Default)
Open	Open	B
Short	Short	C
Open	Short	D

- During Remote Control Number Switch Mode, press any button at remote control to transmit and store the transmission code to the EEPROM.

4 REMOTE CONTROL RECEIVING SOUND OFF/ON MODE

The Remote Control Receiving Sound OFF/ON Mode will be activated if the Auto OFF/ON button is pressed continuously for more than 16 seconds (4 “beep” sounds will occur at 16th seconds to identify the Remote Control Receiving Sound Off/On Mode is in standby condition) and press “AC Reset” button at remote control.

Press “Auto OFF/ON button” to toggle remote control receiving sound.

- Short “beep”: Turn OFF remote control receiving sound.
- Long “beep”: Turn ON remote control receiving sound.

After Auto OFF/ON Button is pressed, the 20 seconds counter for Remote Control Receiving Sound OFF/ON Mode is restarted.

15.2 Heat Only Operation

15.2.1 How to Activate/Deactivate Heat only Operation

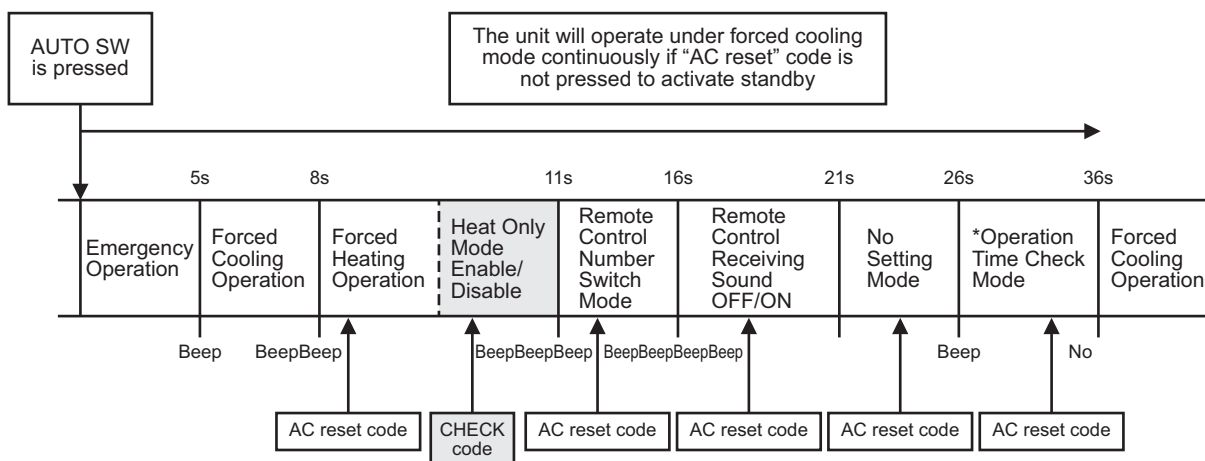

- To enable the “Heat Only” mode, press the AUTO OFF/ON SW for more than 8s and less than 11s, “Beep Beep” sound will be heard, then release the AUTO OFF/ON SW and press remote controller CHECK button. A short “Beep” sound will be heard. “Heat Only” mode is now enable.
- To disable the “Heat Only” mode, press the AUTO OFF/ON SW for more than 8s and less than 11s, “Beep Beep” sound will be heard, then release the AUTO OFF/ON SW and press remote controller CHECK button. A long “Beep” sound will be heard. “Heat Only” mode is now disable.
- To pump down the unit during Heat Only Operation press AUTO switch for 5 seconds.

15.2.2 Operation mode during Heating Only Operation

- The table below shows the operation mode comparison when Heating Only Operation Mode Activated and Deactivated.

Operation Mode	Heating Only Operation Mode Activated	Heating Only Operation Mode Deactivated
AUTO	After 30s sampling, regardless of the indoor intake or outdoor intake temperature judgment, the unit will run Heating operation.	After 30s sampling, the unit will judge the operation mode base on remote controller temperature setting and Indoor Intake Sensor (New Auto Mode) or Outdoor Intake Sensor (Old Auto Mode).
HEAT	The unit will run Heating operation.	The unit will run Heating operation.
COOL	The unit will stop and Power LED blinking.	The unit will run Cooling operation.
DRY	The unit will stop and Power LED blinking.	The unit will run Cooling Dry operation.
NANOE-G Stand-alone	The unit will stop and Power LED blinking.	The unit will run Nanoe-G Stand-alone operation.
Force Cooling	The unit will run Force Cooling Operation for X_CTRYTM [15] minutes	The unit will run Force Cooling operation.
Force Heating	The unit will run Force Heating operation.	The unit will run Force Heating operation.
AUTO (with Timer)	The unit will turn ON by the timer and run Auto Operation. After 30s sampling, regardless of the indoor intake or outdoor intake temperature judgment, the unit will run Heating operation.	The unit will turn ON by the timer and run Auto Operation. After 30s sampling, the unit will judge the operation mode base on remote controller temperature setting and Indoor Intake Sensor (New Auto Mode) or Outdoor Intake Sensor (Old Auto Mode).
HEAT (with Timer)	The unit will turn ON by the timer and run Heating Operation.	The unit will turn ON by the timer and run Heating Operation.
COOL (with Timer)	The unit will not turn ON by the timer. Power LED blinking.	The unit will turn ON by the timer and run Cooling Operation.
DRY (with Timer)	The unit will not turn ON by the timer. Power LED blinking.	The unit will turn ON by the timer and run Cooling Dry Operation.
Cooling Test Mode	The unit will stop and Power LED blinking.	The unit will operate according to specify Cooling test mode operation parameter.
Heating Test Mode	The unit will operate according to specify Heating test mode operation parameter.	The unit will operate according to specify Heating test mode operation parameter.

15.3 Remote Control Button

15.3.1 SET Button

- To check remote control transmission code and store the transmission code to EEPROM:
 - Press "Set" button by using pointer.
 - Press "Timer Set" button until a "beep" sound is heard as confirmation of transmission code changed.
- To limit set temperature range for COOL & DRY, HEAT mode.
 - Press "Set" button by using pointer.
 - Press TEMP increment or decrement button to choose No. 3.
 - Press Timer increment or decrement button to select desired temperature low limit of set temperature for COOL & DRY mode.
 - Press Timer Set button to confirm low limit selection.
 - Press TEMP increment or decrement button to choose No. 4.
 - Press Timer decrement or increment button to select desired temperature high limit of set temperature for COOL & DRY mode.
 - Press Timer Set button to confirm high limit selection.
 - Press TEMP increment or decrement button to choose No. 5.
 - Press Timer increment or decrement button to select desired temperature low limit of set temperature for HEAT mode.
 - Press Timer Set button to confirm low limit selection.
 - Press TEMP increment or decrement button to choose No. 6.
 - Press Timer decrement or increment button to select desired temperature high limit of set temperature for HEAT mode.
 - Press Timer Set button to confirm high limit selection.
 - LCD returns to original display if remote control does not operate for 30 seconds or press Timer Cancel button.

15.3.2 RESET (RC)

- To clear and restore the remote control setting to factory default.
 - Press once to clear the memory.

15.3.3 RESET (AC)

- To restore the unit's setting to factory default.
 - Press once to restore the unit's setting.

15.3.4 TIMER ▲

- To change indoor unit indicator's LED intensity.
 - Press continuously for 5 seconds.

15.3.5 TIMER ▼

- To change remote control display from Degree Celsius (°C) to Degree Fahrenheit (°F).
 - Press continuously for 10 seconds.

15.3.6 Special Setting mode

- LCD display area:

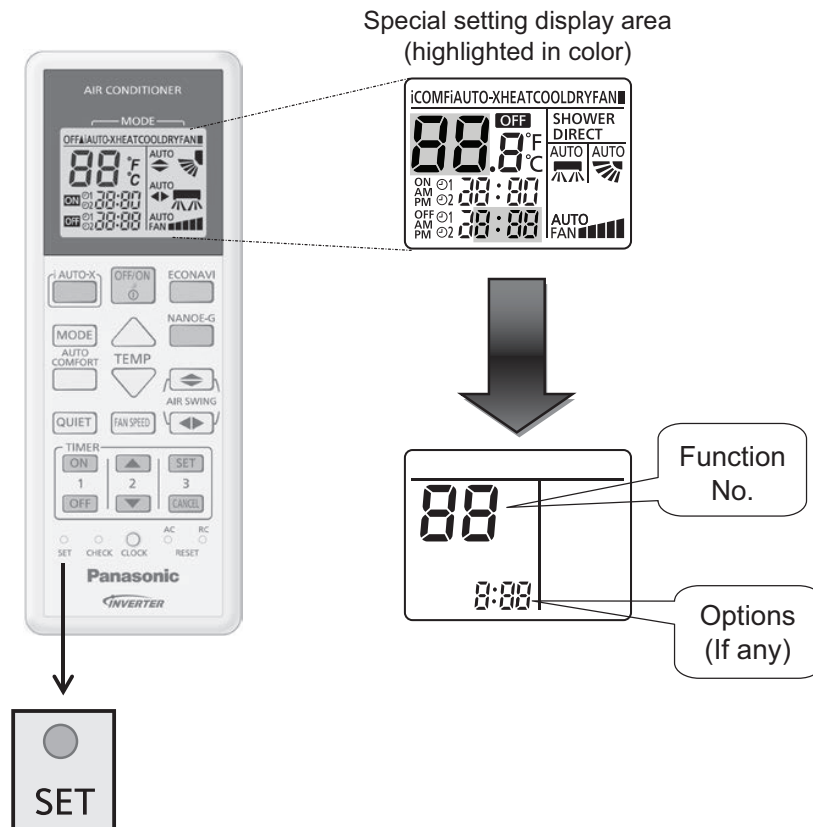

- Cannot enter this special setting mode under the following conditions:

- ① Operation ON.
- ② Under [Real/ON/OFF] time setting mode.

- To enter zone 1 area:

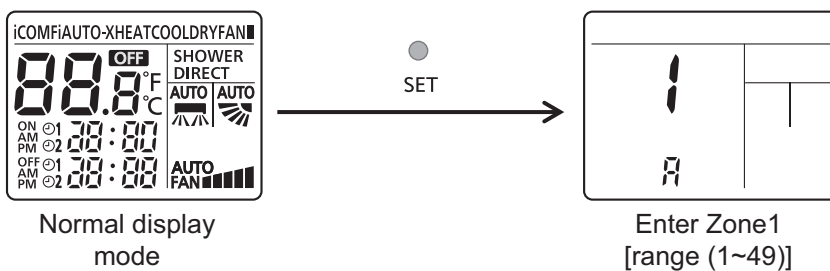

4 To enter zone 2 area: (Press SET continuously for T ≥ 5 secs)

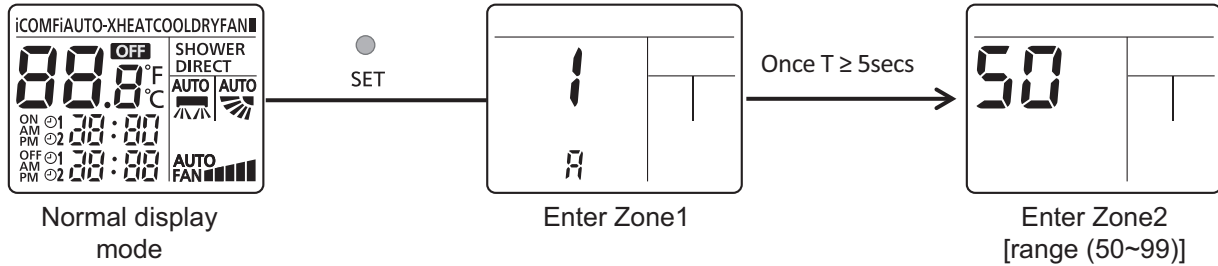

5 Function & Options list:

Note: The functions described in the table may not be applicable to the model and may subject to change without further notice.

	Function		Options	Remark
	No	Name		
Zone 1	1	Remote control number selection	A, B, C, D	
	2	Solar radiation sensitivity level adjustment	1, 2, 3, 4, 5	
	3	[iAUTO-X/iAUTO/iCOMF, Cool & Dry] mode set temperature [Low2] selection	16°C ~ [High2]	
	4	[iAUTO-X/iAUTO/iCOMF, Cool & Dry] mode set temperature [High2] selection	[Low2] ~ 30°C	
	5	Heat mode set temperature Low1 selection	16°C ~ [High1]	
	6	Heat mode set temperature High1 selection	[Low1] ~ 30°C	
	7	Filter cleaning enable/disable selection	00 / 01	
	8	nanoe-G default ON enable/disable selection	00 / 01	
	9	Dust sensor monitoring & LED enable/disable selection	00 / 01	
	10	Auto restart enable/disable selection	00 / 01	
	11	Dust sensor sensitivity level adjustment	1, 2, 3	
	12 ~ 49	Reserve		
Zone 2	50	ECO demo ON	None (No display)	
	51	Light sensor check	None (No display)	
	52	nanoe-G / ECO sensor check	None (No display)	
	53	DOA check	None (No display)	
	54	Odor cut control selection [Enable (01) / Disable (00)]	00 / 01	
	55	Frequency tolerance selection [±3Hz (03) / ±7Hz (07)]	03 / 07	
	56	Fixed fan speed selection during heat mode compressor OFF	00/01	
	57	nanoe check	None (No display)	
	58	Heat mode thermo shift adjustment	-3°C ~ 3°C	
	59	Others (Cool & Dry) mode thermo shift adjustment	-3°C ~ 3°C	
	60	Deice start determination judgment temperature switching	00/01	
	61	Cool mode disable selection [Yes (01) / No (00)]	00/01	
	62	Heat mode disable selection [Yes (01) / No (00)]	00/01	
	63	Base pan heater selection [A / b]	A / b	
	64	Fan speed reduction during cool mode thermo-Off [Enable (01) / Disable (00)]	00/01	
	65 ~ 99	Reserve		

16. Troubleshooting Guide

16.1 Refrigeration Cycle System

In order to diagnose malfunctions, make sure that there are no electrical problems before inspecting the refrigeration cycle. Such problems include insufficient insulation, problem with the power source, malfunction of a compressor and a fan.

The normal outlet air temperature and pressure of the refrigeration cycle depends on various conditions, the standard values for them are shown in the table on the right.

Normal Pressure and Outlet Air Temperature (Standard)

	Gas Pressure MPa (kg/cm ² G)	Outlet air Temperature (°C)
Cooling Mode	0.9 ~ 1.2 (9 ~ 12)	12 ~ 16
Heating Mode	2.3 ~ 2.9 (23 ~ 29)	36 ~ 45

- *Condition:
- Indoor fan speed = High
 - Outdoor temperature 35°C at the cooling mode and 7°C at the heating mode
 - Compressor operates at rated frequency

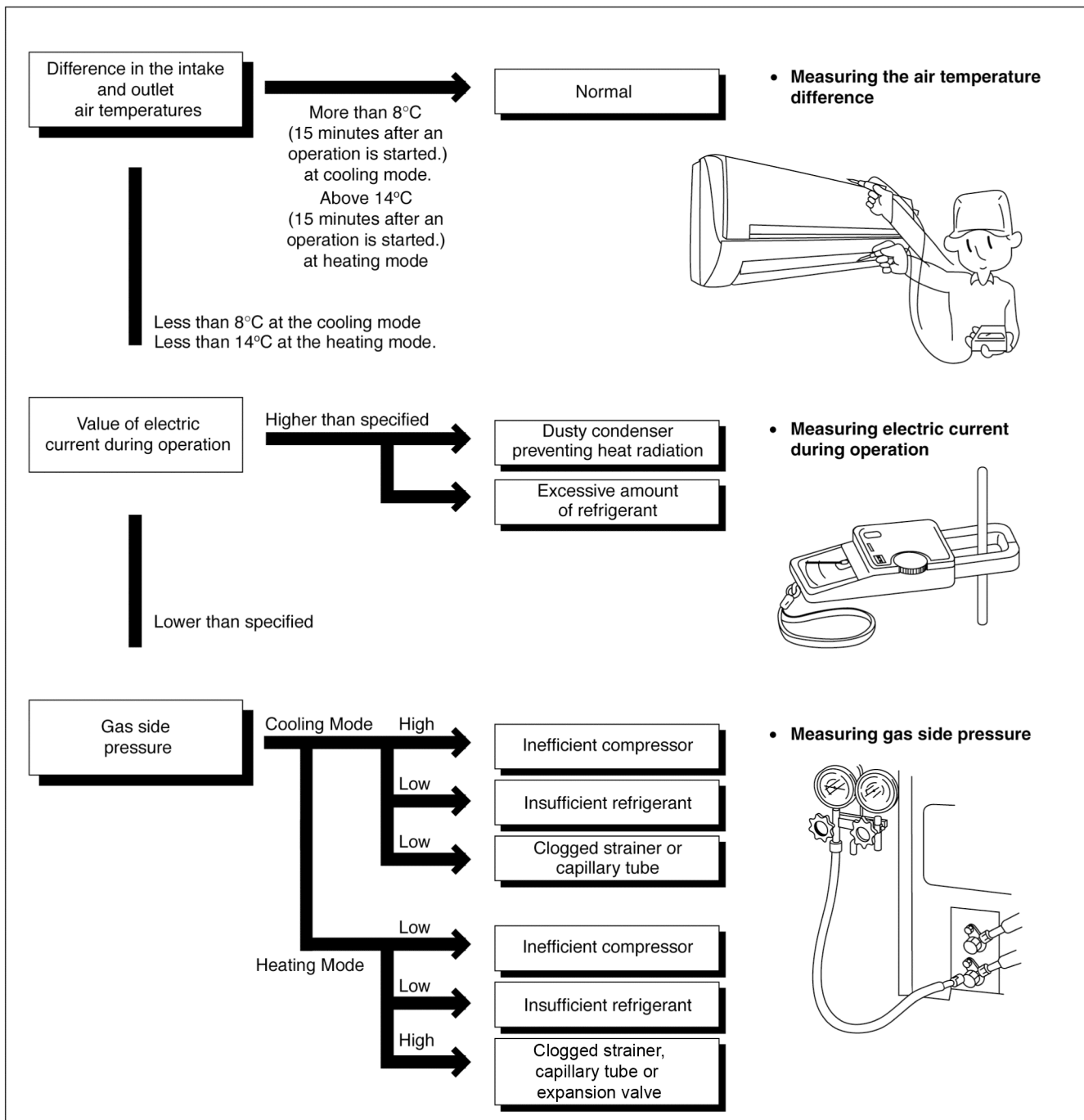

16.1.1 Relationship Between the Condition of the Air Conditioner and Pressure and Electric Current

Condition of the air conditioner	Cooling Mode			Heating Mode		
	Low Pressure	High Pressure	Electric current during operation	Low Pressure	High Pressure	Electric current during operation
Insufficient refrigerant (gas leakage)	↘	↘	↘	↘	↘	↘
Clogged capillary tube or Strainer	↘	↘	↘	↗	↗	↗
Short circuit in the indoor unit	↘	↘	↘	↗	↗	↗
Heat radiation deficiency of the outdoor unit	↗	↗	↗	↘	↘	↘
Inefficient compression	↗	↘	↘	↗	↘	↘

- Carry out the measurement of pressure, electric current, and temperature fifteen minutes after an operation is started.

16.2 Breakdown Self Diagnosis Function

16.2.1 Self Diagnosis Function (Three Digits Alphanumeric Code)

- Once abnormality has occurred during operation, the unit will stop its operation, and Timer LED blinks.
 - Although Timer LED goes off when power supply is turned off, if the unit is operated under a breakdown condition, the LED will light up again.
 - In operation after breakdown repair, the Timer LED will no more blink. The last error code (abnormality) will be stored in IC memory.
- 5 Every press of the button (up or down) will increase abnormality numbers and transmit abnormality code signal to the main unit.
 - 6 When the latest abnormality code on the main unit and code transmitted from the remote controller are matched, power LED will light up for 30 seconds and a beep sound (continuously for 4 seconds) will be heard. If no codes are matched, power LED will light up for 0.5 seconds and no sound will be heard.

16.2.2 To Make a Diagnosis

- 1 Timer LED start to blink and the unit automatically stops the operation.
- 2 Press the CHECK button on the remote controller continuously for 5 seconds.
- 3 “- -” will be displayed on the remote controller display.
Note: Display only for “- -”. (No transmitting signal, no receiving sound and no Power LED blinking.)
- 4 Press the “TIMER” ▲ or ▼ button on the remote controller. The code “H00” (no abnormality) will be displayed and signal will be transmitted to the main unit.
- 5 Every press of the button (up or down) will increase abnormality numbers and transmit abnormality code signal to the main unit.
- 6 When the latest abnormality code on the main unit and code transmitted from the remote controller are matched, power LED will light up for 30 seconds and a beep sound (continuously for 4 seconds) will be heard. If no codes are matched, power LED will light up for 0.5 seconds and no sound will be heard.
- 7 The breakdown diagnosis mode will be canceled unless pressing the CHECK button continuously for 5 seconds or operating the unit for 30 seconds.
- 8 The LED will be off if the unit is turned off or the RESET button on the main unit is pressed.

16.2.3 To Display Memorized Error Code (Protective Operation)

- 1 Turn power on.
- 2 Press the CHECK button on the remote controller continuously for 5 seconds.
- 3 “- -” will be displayed on the remote controller display.
Note: Display only for “- -”. (No transmitting signal, no receiving sound and no Power LED blinking.)
- 4 Press the “TIMER” ▲ or ▼ button on the remote controller. The code “H00” (no abnormality) will be displayed and signal will be transmitted to the main unit. The power LED lights up. If no abnormality is stored in the memory, three beeps sound will be heard.

- 7 The breakdown diagnosis mode will be canceled unless pressing the CHECK button continuously for 5 seconds or operating the unit for 30 seconds.
- 8 The same diagnosis can be repeated by turning power on again.

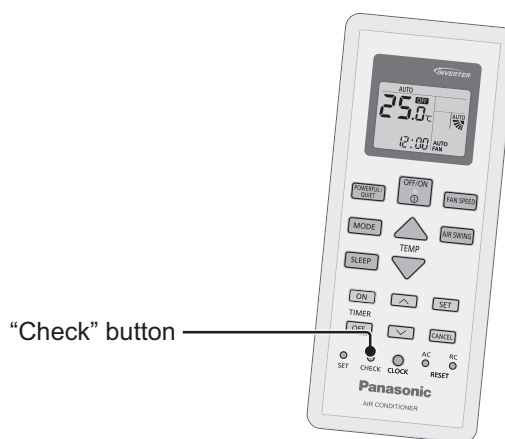

16.2.4 To Clear Memorized Error Code after Repair (Protective Operation)

- 1 Turn power on (in standby condition).
- 2 Press the AUTO button for 5 seconds (A beep receiving sound) on the main unit to operate the unit at Forced Cooling Operation modes.
- 3 Press the CHECK button on the remote controller for about 1 second with a pointed object to transmit signal to main unit. A beep sound is heard from main unit and the data is cleared.

16.2.5 Temporary Operation (Depending On Breakdown Status)

- 1 Press the AUTO button (A beep receiving sound) on the main unit to operate the unit. (Remote control will become possible.)
- 2 The unit can temporarily be used until repaired.

16.3 Error Codes Table

Diagnosis display	Abnormality / Protection control	Abnormality Judgment	Protection Operation	Problem	Check location
H00	No memory of failure	—	Normal operation	—	—
H11	Indoor/outdoor abnormal communication	After operation for 1 minute	Indoor fan only operation can start by entering into force cooling operation	Indoor/outdoor communication not establish	<ul style="list-style-type: none"> Indoor/outdoor wire terminal Indoor/outdoor PCB Indoor/outdoor connection wire
H12	Indoor unit capacity unmatched	90s after power supply	—	Total indoor capability more than maximum limit or less than minimum limit, or number of indoor unit less than two	<ul style="list-style-type: none"> Indoor/outdoor connection wire Indoor/outdoor PCB Specification and combination table in catalogue
H14	Indoor intake air temperature sensor abnormality	Continuous for 5s	—	Indoor intake air temperature sensor open or short circuit	<ul style="list-style-type: none"> Indoor intake air temperature sensor lead wire and connector
H15	Compressor temperature sensor abnormality	Continuous for 5s	—	Compressor temperature sensor open or short circuit	<ul style="list-style-type: none"> Compressor temperature sensor lead wire and connector
H16	Outdoor current transformer (CT) abnormality	—	—	Current transformer faulty or compressor faulty	<ul style="list-style-type: none"> Outdoor PCB faulty or compressor faulty
H19	Indoor fan motor mechanism lock	Continuous happen for 7 times	—	Indoor fan motor lock or feedback abnormal	<ul style="list-style-type: none"> Fan motor lead wire and connector Fan motor lock or block
H23	Indoor heat exchanger temperature sensor abnormality	Continuous for 5s	—	Indoor heat exchanger temperature sensor open or short circuit	<ul style="list-style-type: none"> Indoor heat exchanger temperature sensor lead wire and connector
H24	Indoor heat exchanger temperature sensor 2 abnormality	Continuous for 5s	—	Indoor heat exchanger temperature sensor 2 open or short circuit	<ul style="list-style-type: none"> Indoor heat exchanger temperature sensor 2 lead wire and connector
H25	Indoor ion device abnormality	Port is ON for 10s during ion device off	—	—	<ul style="list-style-type: none"> ion device PCB
H27	Outdoor air temperature sensor abnormality	Continuous for 5s	—	Outdoor air temperature sensor open or short circuit	<ul style="list-style-type: none"> Outdoor air temperature sensor lead wire and connector
H28	Outdoor heat exchanger temperature sensor 1 abnormality	Continuous for 5s	—	Outdoor heat exchanger temperature sensor 1 open or short circuit	<ul style="list-style-type: none"> Outdoor heat exchanger temperature sensor 1 lead wire and connector
H30	Outdoor discharge pipe temperature sensor abnormality	Continuous for 5s	—	Outdoor discharge pipe temperature sensor open or short circuit	<ul style="list-style-type: none"> Outdoor discharge pipe temperature sensor lead wire and connector
H32	Outdoor heat exchanger temperature sensor 2 abnormality	Continuous for 5s	—	Outdoor heat exchanger temperature sensor 2 open or short circuit	<ul style="list-style-type: none"> Outdoor heat exchanger temperature sensor 2 lead wire and connector
H33	Indoor / outdoor misconnection abnormality	—	—	Indoor and outdoor rated voltage different	<ul style="list-style-type: none"> Indoor and outdoor units check
H34	Outdoor heat sink temperature sensor abnormality	Continuous for 2s	—	Outdoor heat sink temperature sensor open or short circuit	<ul style="list-style-type: none"> Outdoor heat sink sensor
H36	Outdoor gas pipe temperature sensor abnormality	Continuous for 5s	Heating protection operation only	Outdoor gas pipe temperature sensor open or short circuit	<ul style="list-style-type: none"> Outdoor gas pipe temperature sensor lead wire and connector
H37	Outdoor liquid pipe temperature sensor abnormality	Continuous for 5s	Cooling protection operation only	Outdoor liquid pipe temperature sensor open or short circuit	<ul style="list-style-type: none"> Outdoor liquid pipe temperature sensor lead wire and connector
H38	Indoor/Outdoor mismatch (brand code)	—	—	Brand code not match	<ul style="list-style-type: none"> Check indoor unit and outdoor unit
H39	Abnormal indoor operating unit or standby units	3 times happen within 40 minutes	—	Wrong wiring and connecting pipe, expansion valve abnormality, indoor heat exchanger sensor open circuit	<ul style="list-style-type: none"> Check indoor/outdoor connection wire and connection pipe Indoor heat exchanger sensor lead wire and connector Expansion valve and lead wire and connector

Diagnosis display	Abnormality / Protection control	Abnormality Judgment	Protection Operation	Problem	Check location
H41	Abnormal wiring or piping connection	—	—	Wrong wiring and connecting pipe, expansion valve abnormality	<ul style="list-style-type: none"> • Check indoor/outdoor connection wire and connection pipe • Expansion valve and lead wire and connector
H59	ECONAVI sensor abnormality	Continuous for 25s	—	ECONAVI sensor open or short circuit	<ul style="list-style-type: none"> • ECONAVI sensor (defective or disconnected) • ECONAVI PCB
H64	Outdoor high pressure sensor abnormality	Continuous for 1 minute	—	High pressure sensor open circuit during compressor stop	<ul style="list-style-type: none"> • High pressure sensor • Lead wire and connector
H67	nanoe abnormality	nanoe stop for 5 minutes for 3 times	—	nanoe faulty	<ul style="list-style-type: none"> • PCB • nanoe system • High voltage
H70	Light sensor abnormality	Continuous for 24 hours, 15 days	—	Light sensor open or short circuit	<ul style="list-style-type: none"> • Light sensor (defective or disconnect)
H97	Outdoor fan motor mechanism lock	2 times happen within 30 minutes	—	Outdoor fan motor lock or feedback abnormal	<ul style="list-style-type: none"> • Outdoor fan motor lead wire and connector • Fan motor lock or block
H98	Indoor high pressure protection	—	—	Indoor high pressure protection (Heating)	<ul style="list-style-type: none"> • Check indoor heat exchanger • Air filter dirty • Air circulation short circuit
H99	Indoor operating unit freeze protection	—	—	Indoor freeze protection (Cooling)	<ul style="list-style-type: none"> • Check indoor heat exchanger • Air filter dirty • Air circulation short circuit
F11	4-way valve switching abnormality	4 times happen within 30 minutes	—	4-way valve switching abnormal	<ul style="list-style-type: none"> • 4-way valve • Lead wire and connector
F17	Indoor standby units freezing abnormality	3 times happen within 40 minutes	—	Wrong wiring and connecting pipe, expansion valve leakage, indoor heat exchanger sensor open circuit	<ul style="list-style-type: none"> • Check indoor/outdoor connection wire and pipe • Indoor heat exchanger sensor lead wire and connector • Expansion valve lead wire and connector
F90	Power factor correction (PFC) circuit protection	4 times happen within 10 minutes	—	Power factor correction circuit abnormal	<ul style="list-style-type: none"> • Outdoor PCB faulty
F91	Refrigeration cycle abnormality	2 times happen within 20 minutes	—	Refrigeration cycle abnormal	<ul style="list-style-type: none"> • Insufficient refrigerant or valve close
F93	Compressor abnormal revolution	4 times happen within 20 minutes	—	Compressor abnormal revolution	<ul style="list-style-type: none"> • Power transistor module faulty or compressor lock
F94	Compressor discharge overshoot protection	4 times happen within 30 minutes	—	Compressor discharge pressure overshoot	<ul style="list-style-type: none"> • Check refrigeration system
F95	Outdoor cooling high pressure protection	4 times happen within 20 minutes	—	Cooling high pressure protection	<ul style="list-style-type: none"> • Check refrigeration system • Outdoor air circuit
F96	Power transistor module overheating protection	4 times happen within 30 minutes	—	Power transistor module overheat	<ul style="list-style-type: none"> • PCB faulty • Outdoor air circuit (fan motor)
F97	Compressor overheating protection	3 times happen within 30 minutes	—	Compressor overheat	<ul style="list-style-type: none"> • Insufficient refrigerant
F98	Total running current protection	3 times happen within 20 minutes	—	Total current protection	<ul style="list-style-type: none"> • Check refrigeration system • Power source or compressor lock
F99	Outdoor direct current (DC) peak detection	Continuous happen for 7 times	—	Power transistor module current protection	<ul style="list-style-type: none"> • Power transistor module faulty or compressor lock

16.4 Self-diagnosis Method

16.4.1 H11 (Indoor/Outdoor Abnormal Communication)

Malfunction Decision Conditions

- During startup and operation of cooling and heating, the data received from outdoor unit in indoor unit signal transmission is checked whether it is normal.

Malfunction Caused

- Faulty indoor unit PCB.
- Faulty outdoor unit PCB.
- Indoor unit-outdoor unit signal transmission error due to wiring error.
- Indoor unit-outdoor unit signal transmission error due to breaking of wire in the connection wires between the indoor and outdoor units.

Troubleshooting

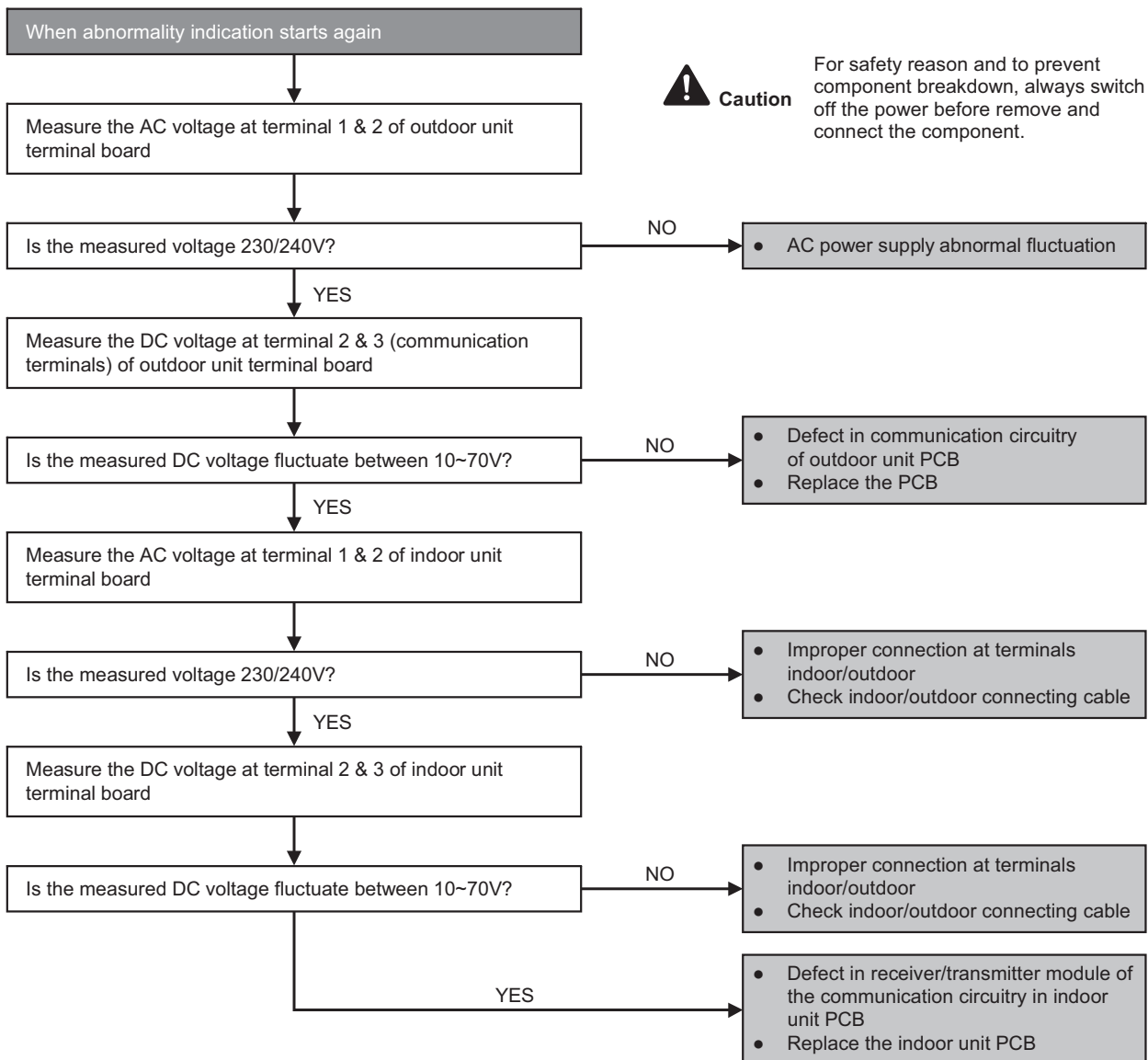

16.4.2 H12 (Indoor/Outdoor Capacity Rank Mismatched)

Malfunction Decision Conditions

- During startup, error code appears when different types of indoor and outdoor units are interconnected.

Malfunction Caused

- Wrong models interconnected.
- Wrong indoor unit or outdoor unit PCBs mounted.
- Indoor unit or outdoor unit PCBs defective.
- Indoor-outdoor unit signal transmission error due to wrong wiring.
- Indoor-outdoor unit signal transmission error due to breaking of wire 3 in the connection wires between the indoor and outdoor units.

Troubleshooting

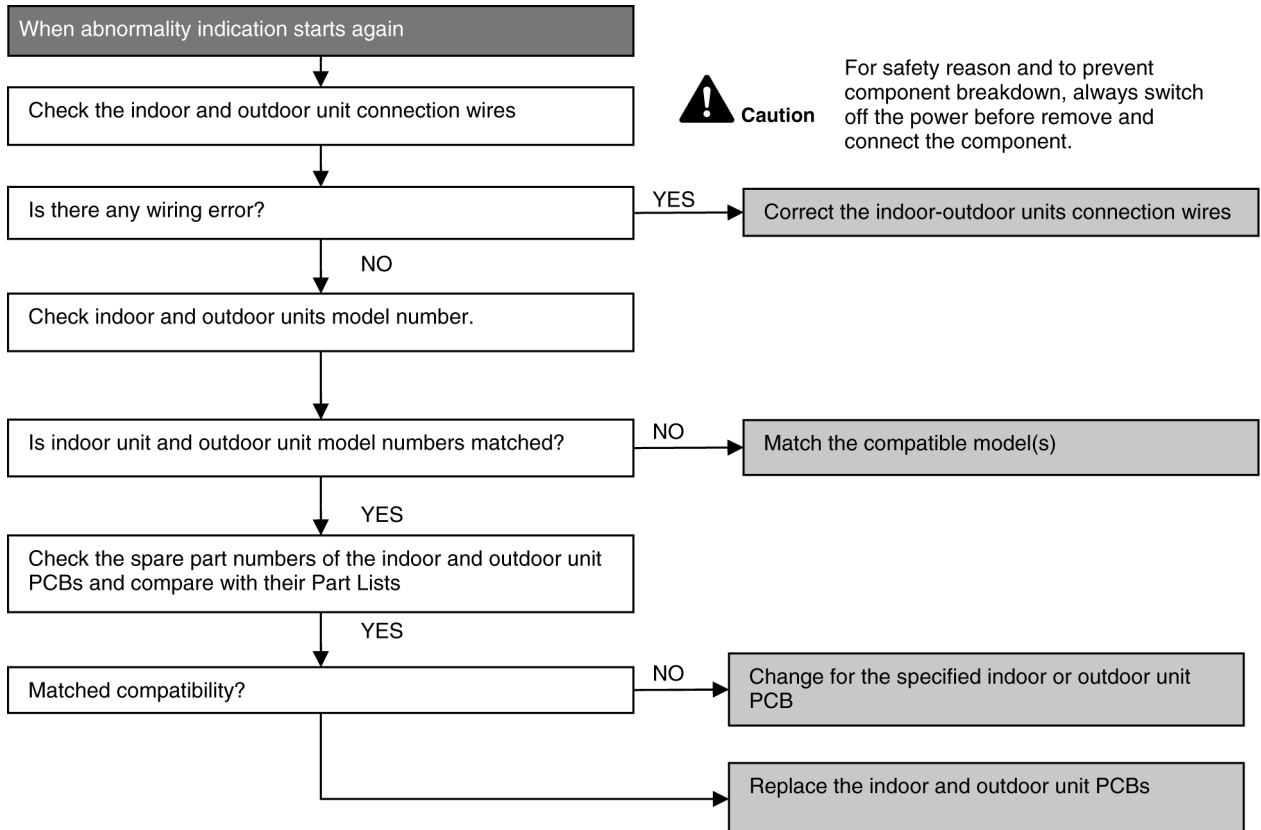

16.4.3 H14 (Indoor Intake Air Temperature Sensor Abnormality)

Malfunction Decision Conditions

- During startup and operation of cooling and heating, the temperatures detected by the indoor intake air temperature sensor are used to determine sensor errors.

Malfunction Caused

- Faulty connector connection.
- Faulty sensor.
- Faulty PCB.

Troubleshooting

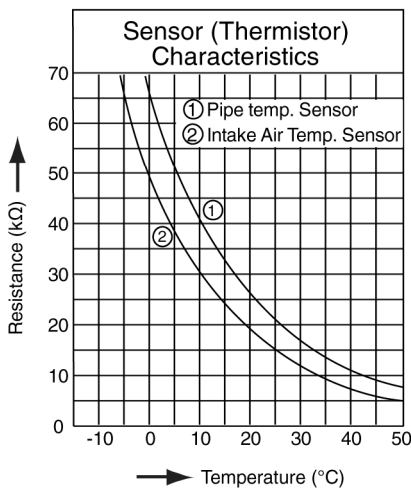
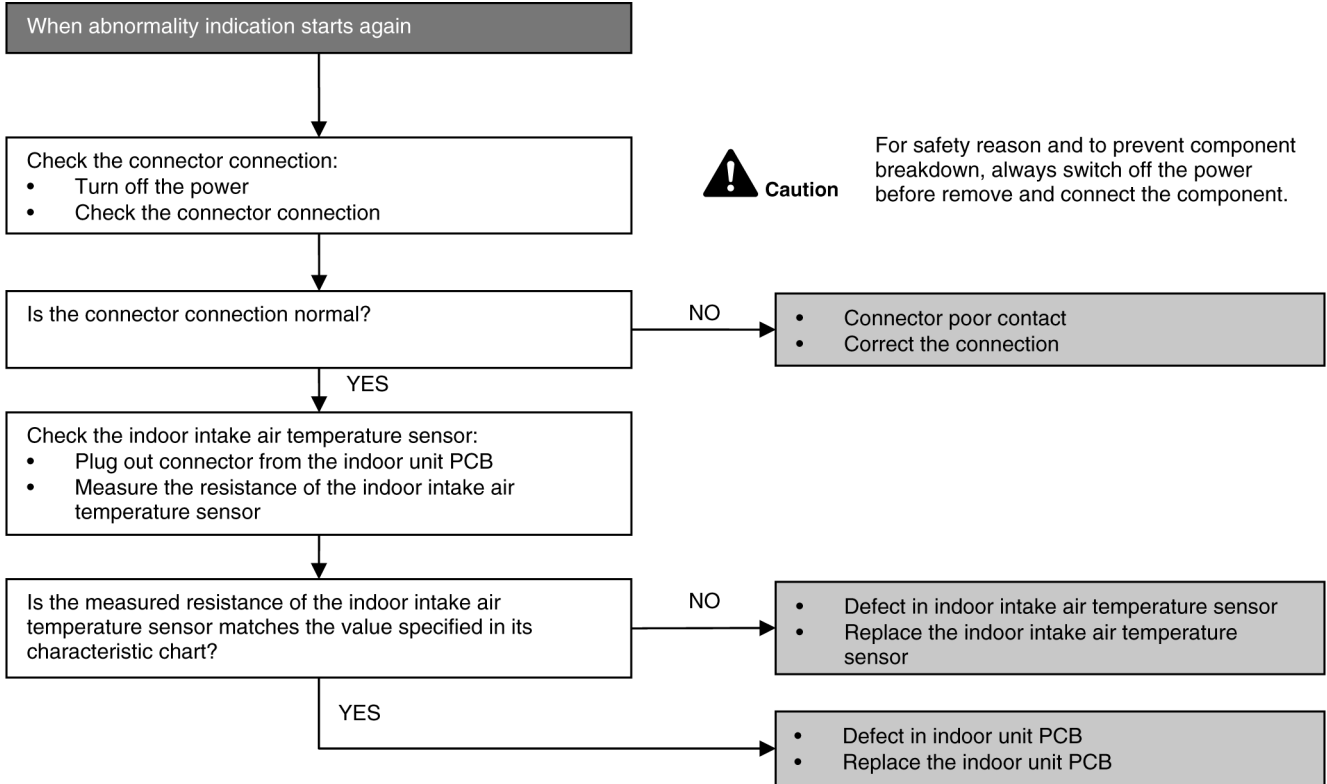

16.4.4 H15 (Compressor Temperature Sensor Abnormality)

Malfunction Decision Conditions

- During startup and operation of cooling and heating, the temperatures detected by the outdoor compressor temperature sensor are used to determine sensor errors.

Malfunction Caused

- Faulty connector connection.
- Faulty sensor.
- Faulty PCB.

Troubleshooting

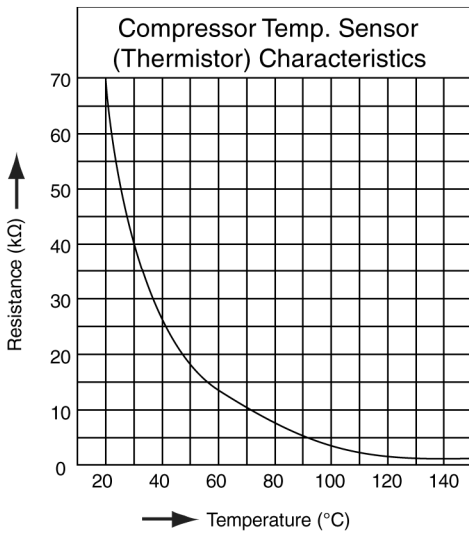
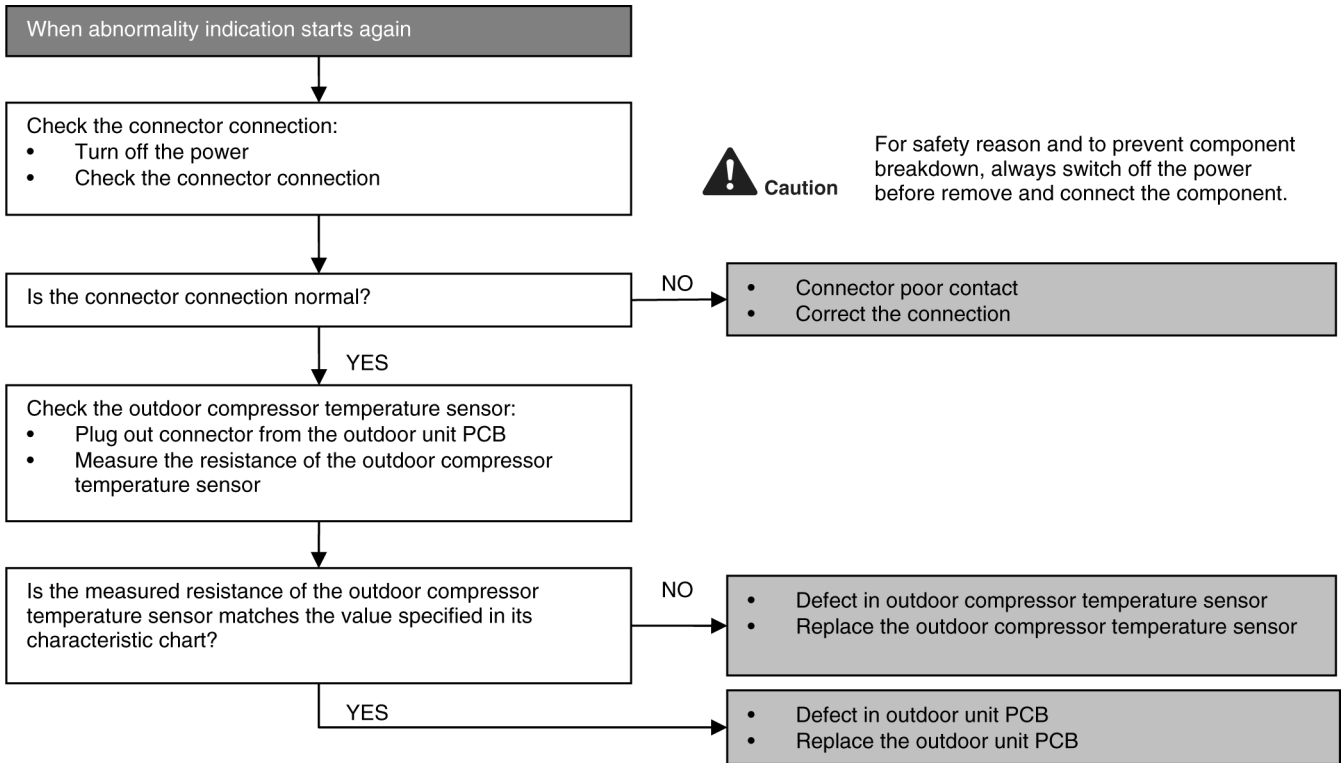

16.4.5 H16 (Outdoor Current Transformer)

Malfunction Decision Conditions

- An input current, detected by Current Transformer CT, is below threshold value when the compressor is operating at certain frequency value for 3 minutes.

Malfunction Caused

- Lack of gas
- Broken CT (current transformer)
- Broken Outdoor PCB

Troubleshooting

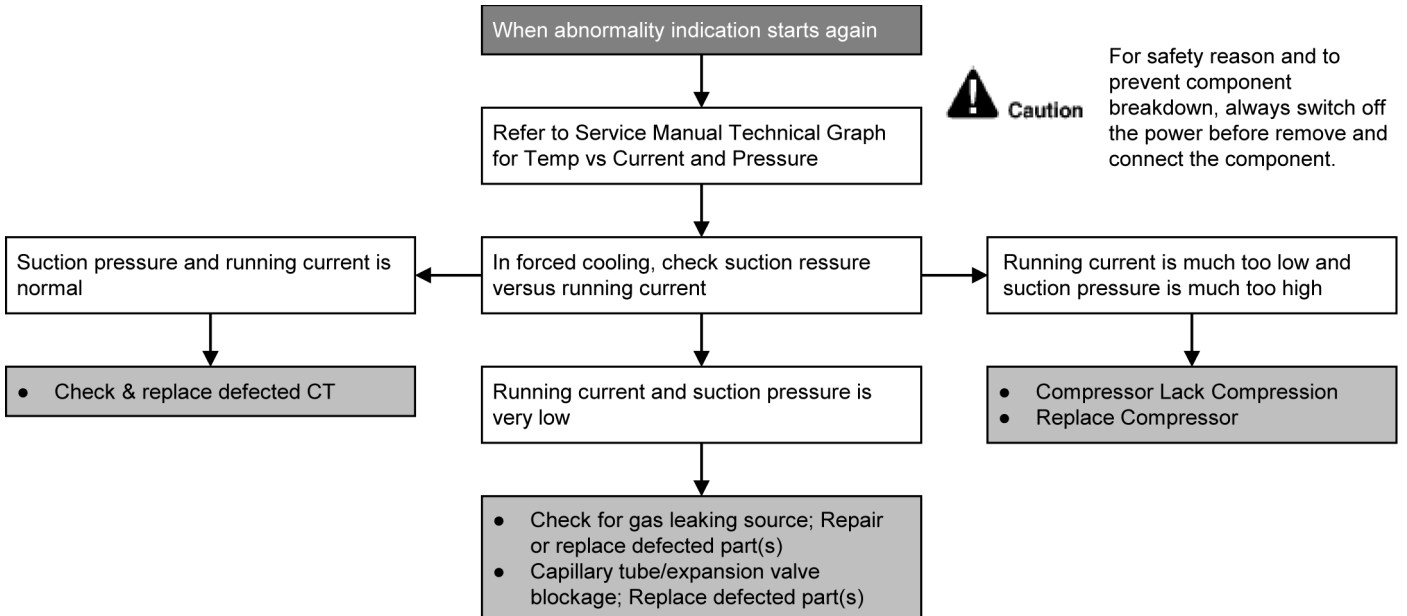

16.4.6 H19 (Indoor Fan Motor – DC Motor Mechanism Locked)

Malfunction Decision Conditions

- The rotation speed detected by the Hall IC during fan motor operation is used to determine abnormal fan motor (feedback of rotation > 2550 rpm or < 50 rpm)

Malfunction Caused

- Operation stops due to short circuit inside the fan motor winding.
- Operation stops due to breaking of wire inside the fan motor.
- Operation stops due to breaking of fan motor lead wires.
- Operation stops due to Hall IC malfunction.
- Operation error due to faulty indoor unit PCB.

Troubleshooting

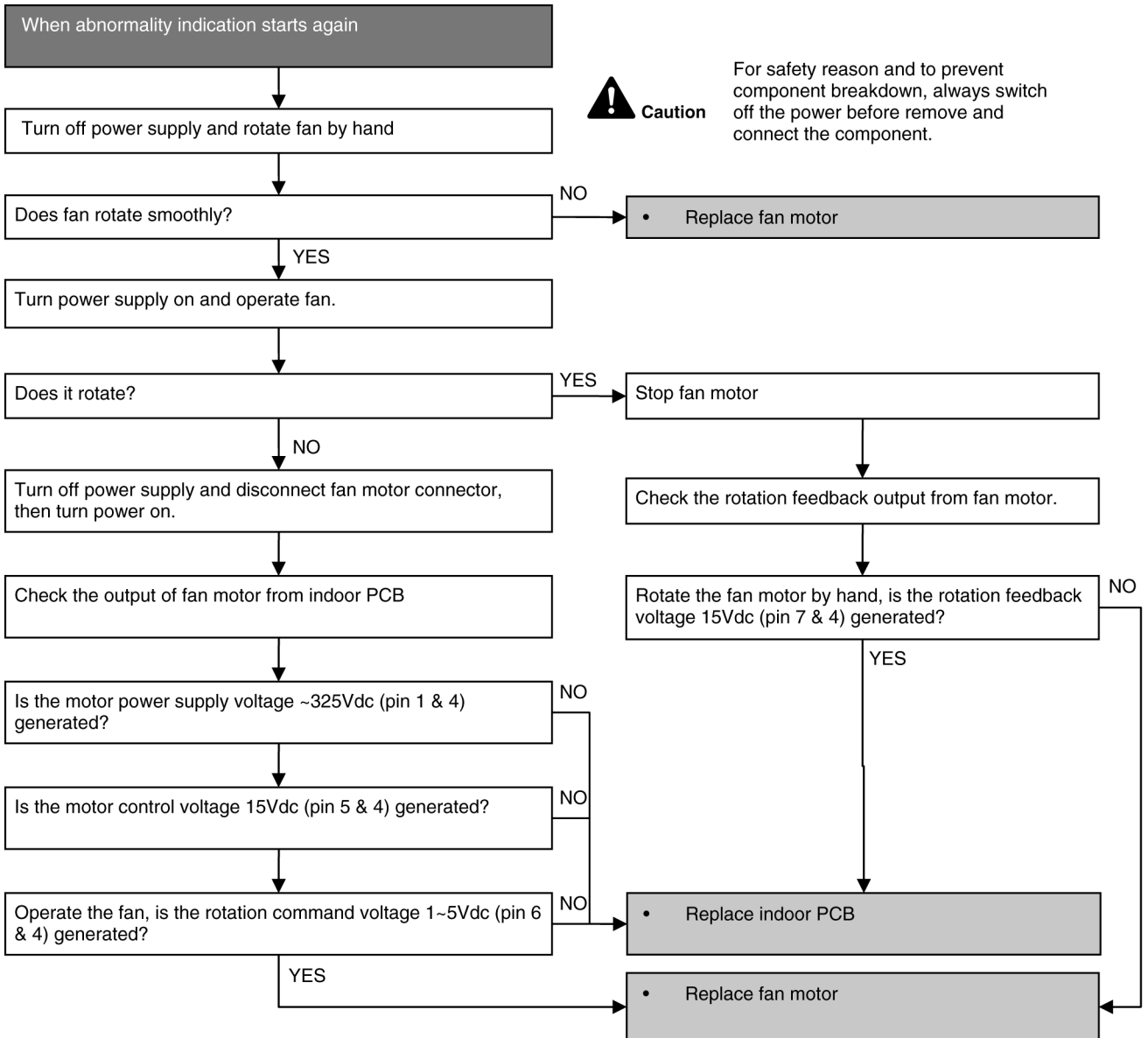

16.4.7 H23 (Indoor Pipe Temperature Sensor Abnormality)

Malfunction Decision Conditions

- During startup and operation of cooling and heating, the temperatures detected by the indoor heat exchanger temperature sensor are used to determine sensor errors.

Malfunction Caused

- Faulty connector connection.
- Faulty sensor.
- Faulty PCB.

Troubleshooting

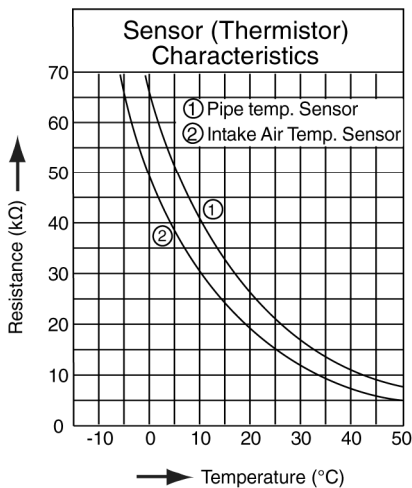
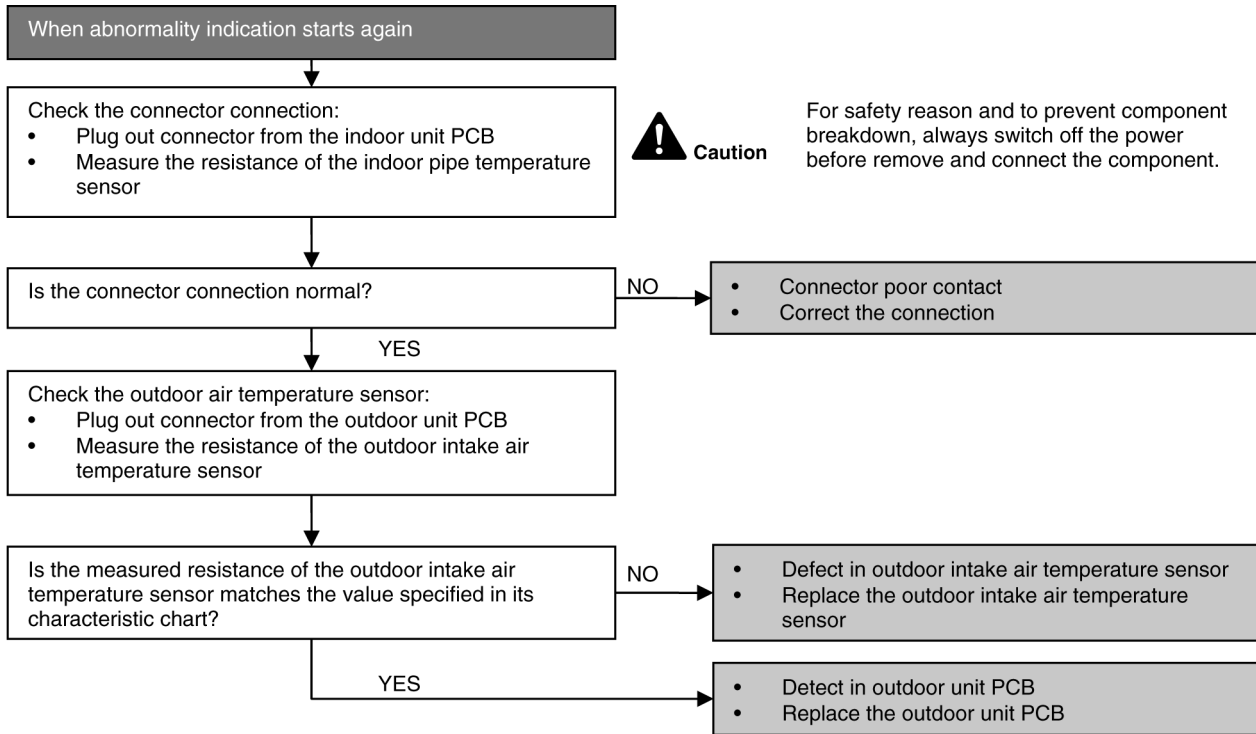

16.4.8 H27 (Outdoor Air Temperature Sensor Abnormality)

Malfunction Decision Conditions

- During startup and operation of cooling and heating, the temperatures detected by the outdoor air temperature sensor are used to determine sensor errors.

Malfunction Caused

- Faulty connector connection.
- Faulty sensor.
- Faulty PCB.

Troubleshooting

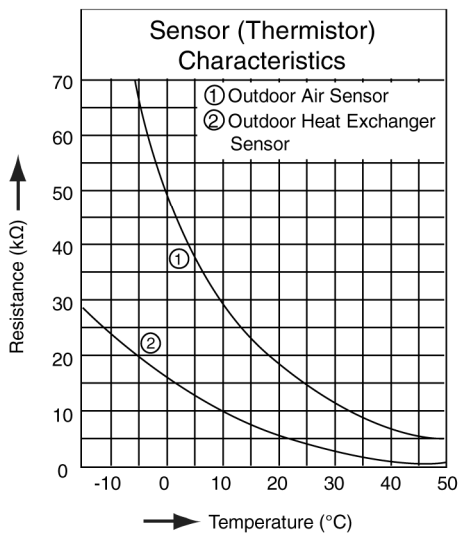
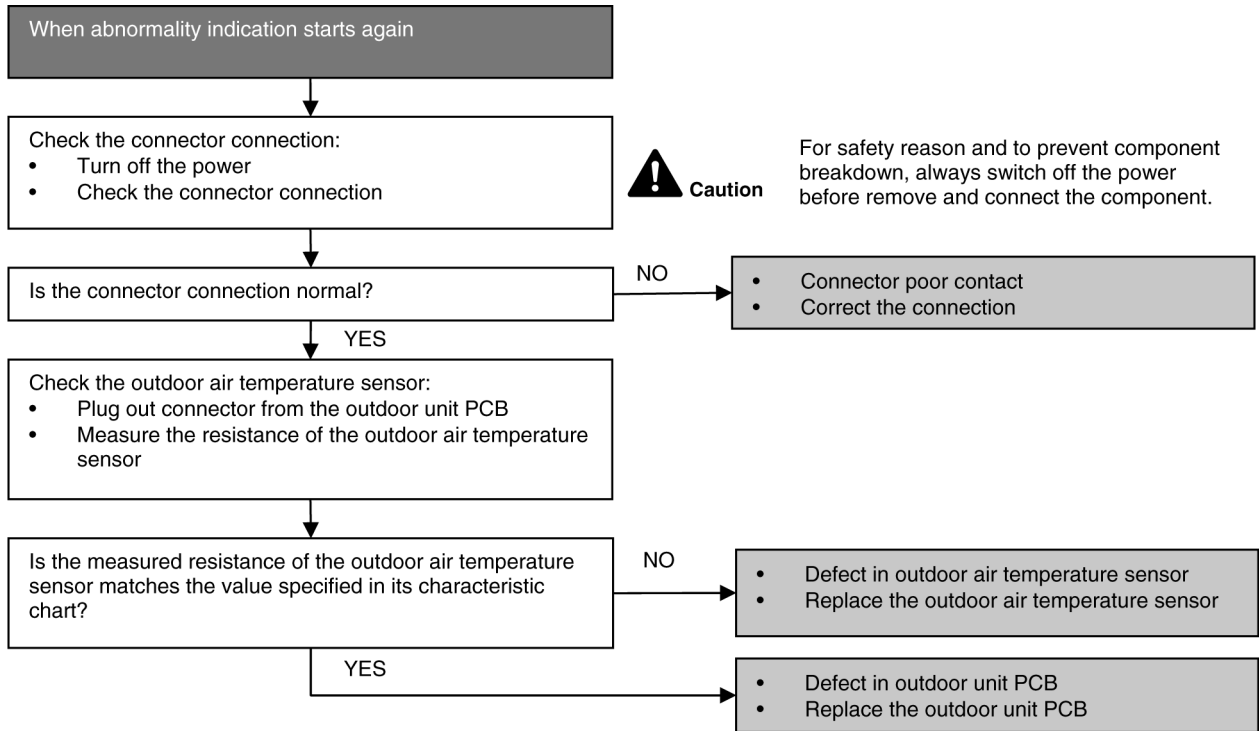

16.4.9 H28 (Outdoor Pipe Temperature Sensor Abnormality)

Malfunction Decision Conditions

- During startup and operation of cooling and heating, the temperatures detected by the outdoor pipe temperature sensor are used to determine sensor errors.

Malfunction Caused

- Faulty connector connection.
- Faulty sensor.
- Faulty PCB.

Troubleshooting

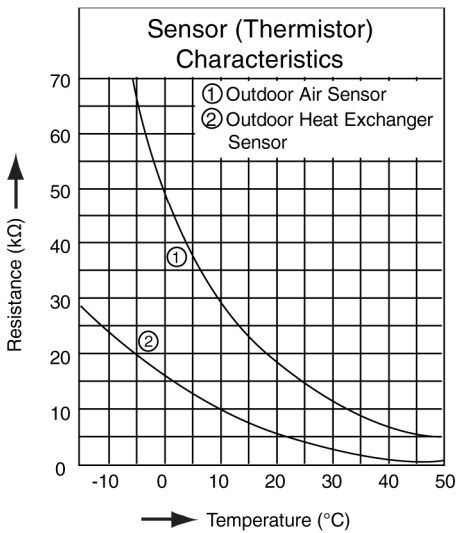
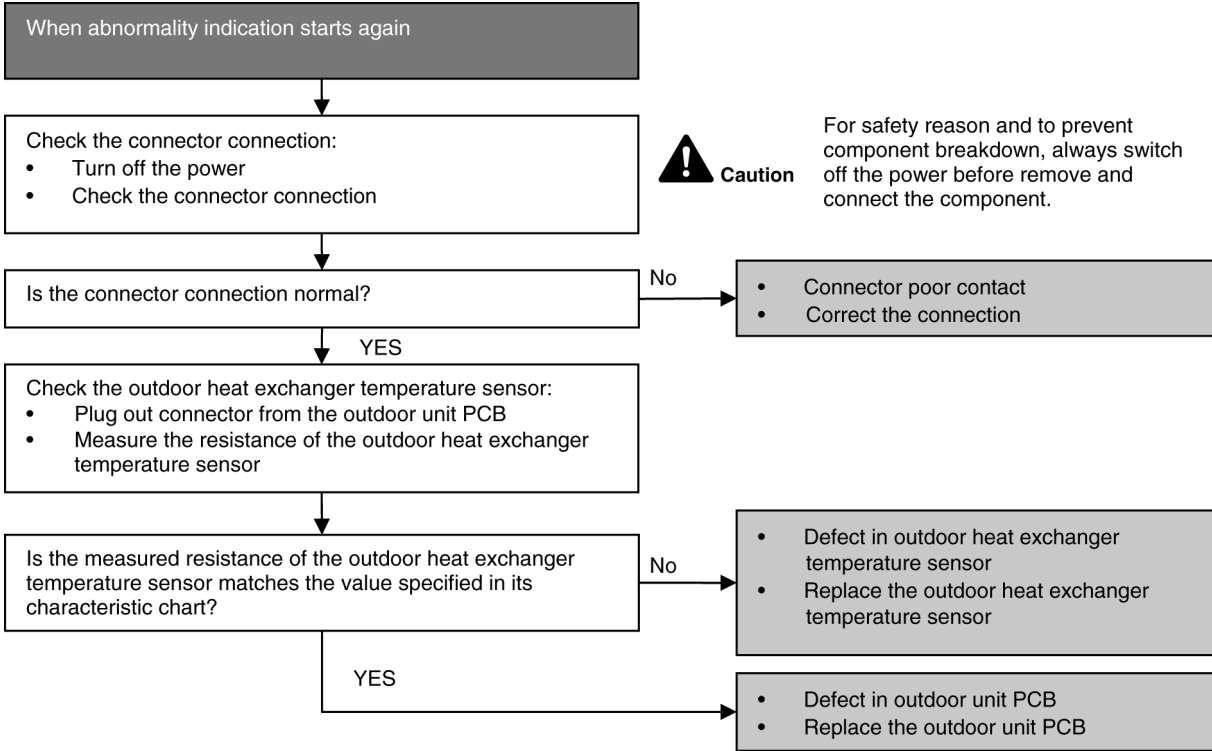

16.4.10 H30 (Compressor Discharge Temperature Sensor Abnormality)

Malfunction Decision Conditions

- During startup and operation of cooling and heating, the temperatures detected by the outdoor discharge pipe temperature sensor are used to determine sensor errors.

Malfunction Caused

- Faulty connector connection.
- Faulty sensor.
- Faulty PCB.

Troubleshooting

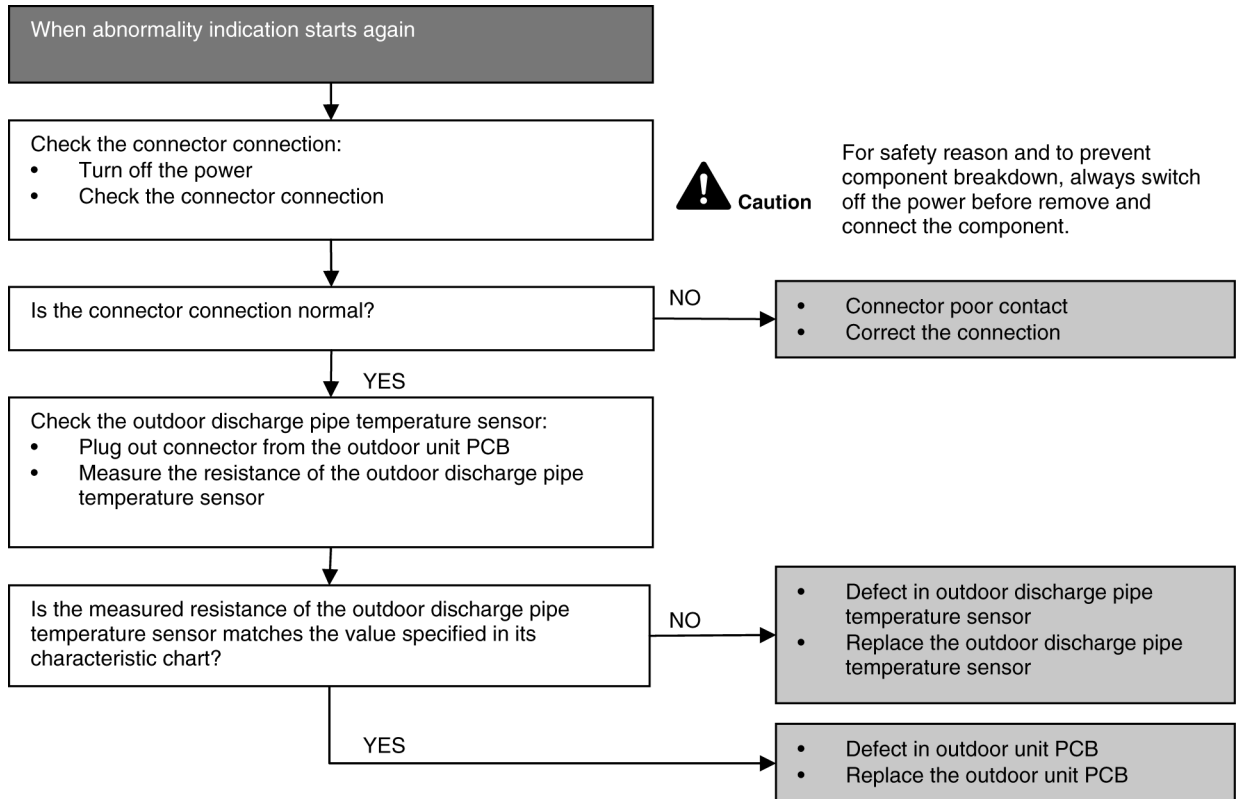

16.4.11 H32 (Outdoor Heat Exchanger Temperature Sensor 2 Abnormality)

Malfunction Decision Conditions

- During startup and operation of cooling and heating, the temperatures detected by the outdoor heat exchanger temperature sensor are used to determine sensor errors.

Malfunction Caused

- Faulty connector connection.
- Faulty sensor.
- Faulty PCB.

Troubleshooting

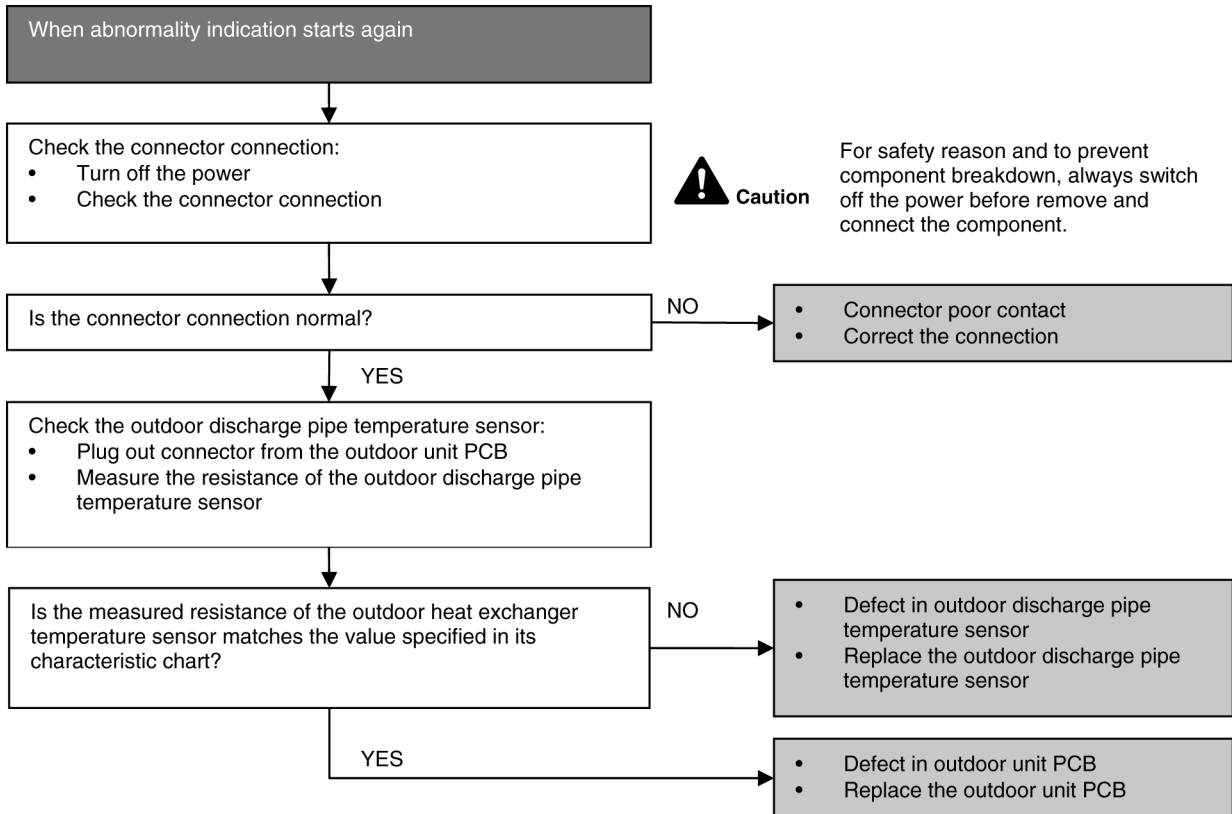

16.4.12 H33 (Unspecified Voltage between Indoor and Outdoor)

Malfunction Decision Conditions

- The supply power is detected for its requirement by the indoor/outdoor transmission.

Malfunction Caused

- Wrong models interconnected.
- Wrong indoor unit and outdoor unit PCBs used.
- Indoor unit or outdoor unit PCB defective.

Troubleshooting

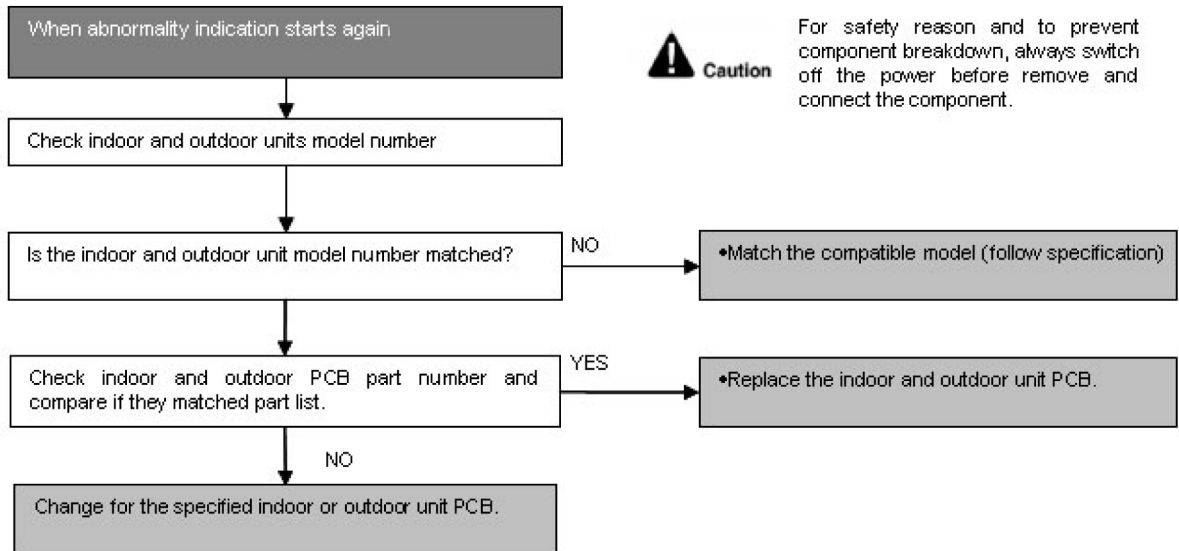

16.4.13 H34 (Outdoor Heat Sink Temperature Sensor Abnormality)

Malfunction Decision Conditions

- During startup and operation of cooling and heating, the temperatures detected by the outdoor heat sink temperature sensor are used to determine sensor errors.

Malfunction Caused

- Faulty connector connection.
- Faulty sensor.
- Faulty PCB.

Troubleshooting

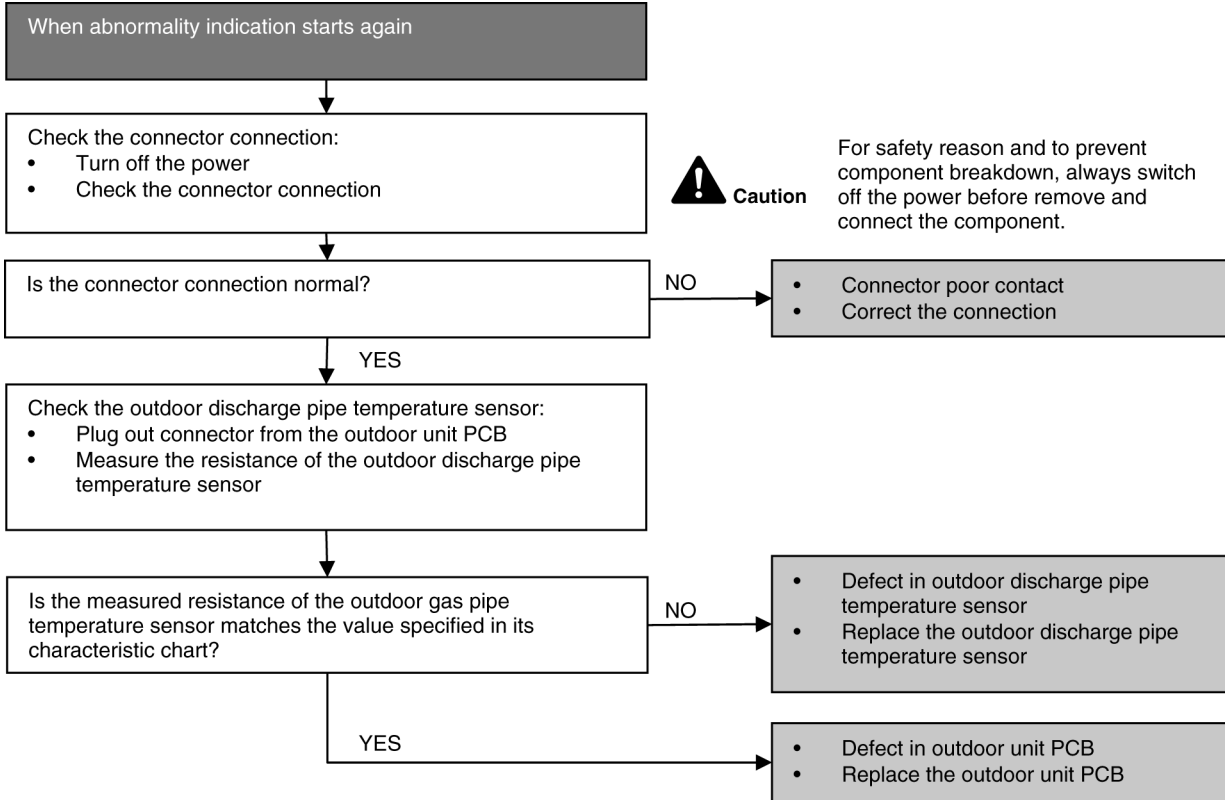

16.4.14 H36 (Outdoor Gas Pipe Sensor Abnormality)

Malfunction Decision Conditions

- During startup and operation of cooling and heating, the temperatures detected by the outdoor gas pipe temperature sensor are used to determine sensor errors.

Malfunction Caused

- Faulty connector connection.
- Faulty sensor.
- Faulty PCB.

Troubleshooting

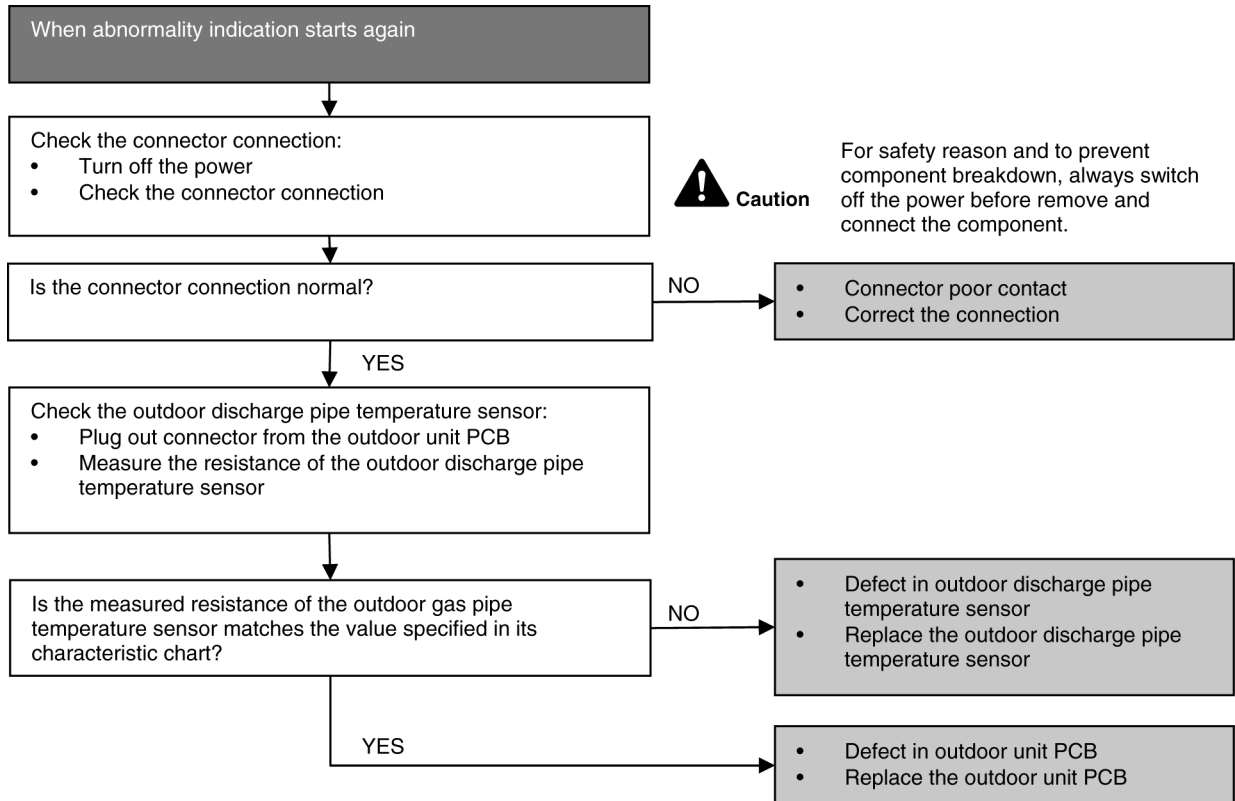

16.4.15 H37 (Outdoor Liquid Pipe Temperature Sensor Abnormality)

Malfunction Decision Conditions

- During startup and operation of cooling and heating, the temperatures detected by the outdoor liquid pipe temperature sensor are used to determine sensor errors.

Malfunction Caused

- Faulty connector connection.
- Faulty sensor.
- Faulty PCB.

Troubleshooting

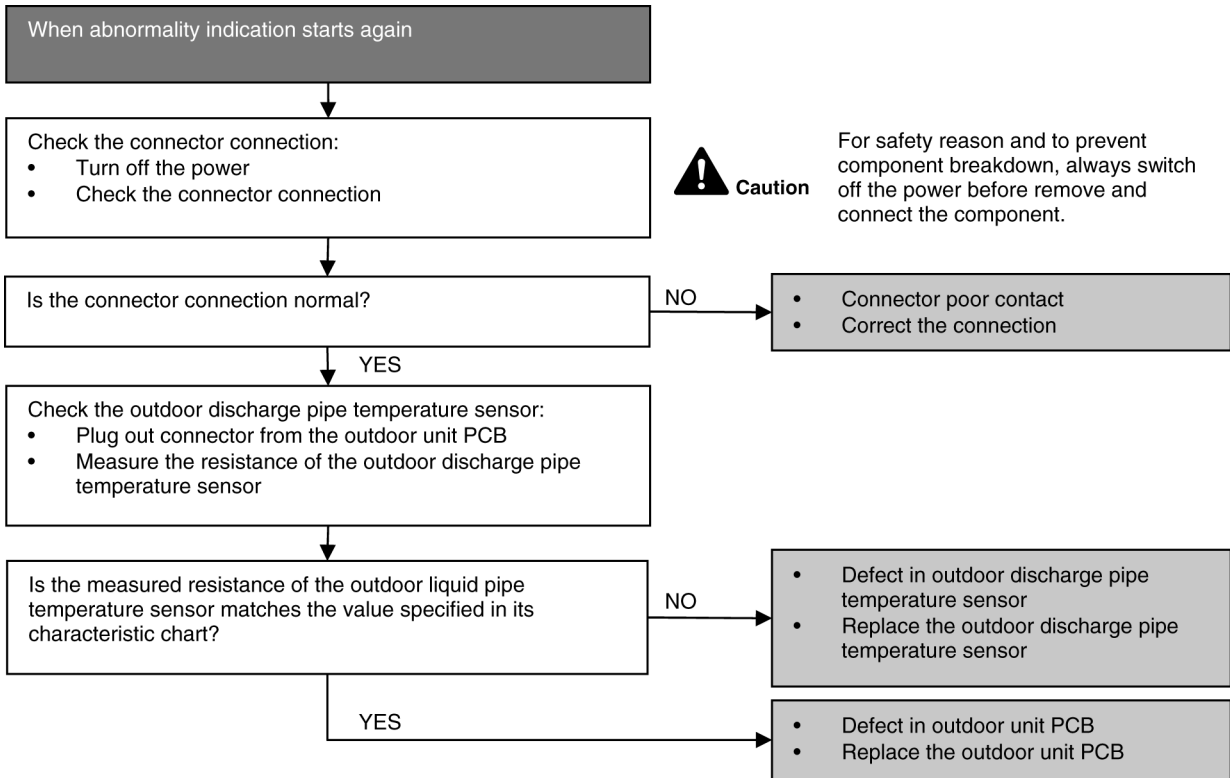

16.4.16 H97 (Outdoor Fan Motor – DC Motor Mechanism Locked)

Malfunction Decision Conditions

- The rotation speed detected by the Hall IC during fan motor operation is used to determine abnormal fan motor.

Malfunction Caused

- Operation stops due to short circuit inside the fan motor winding.
- Operation stops due to breaking of wire inside the fan motor.
- Operation stops due to breaking of fan motor lead wires.
- Operation stops due to Hall IC malfunction.
- Operation error due to faulty outdoor unit PCB.

Troubleshooting

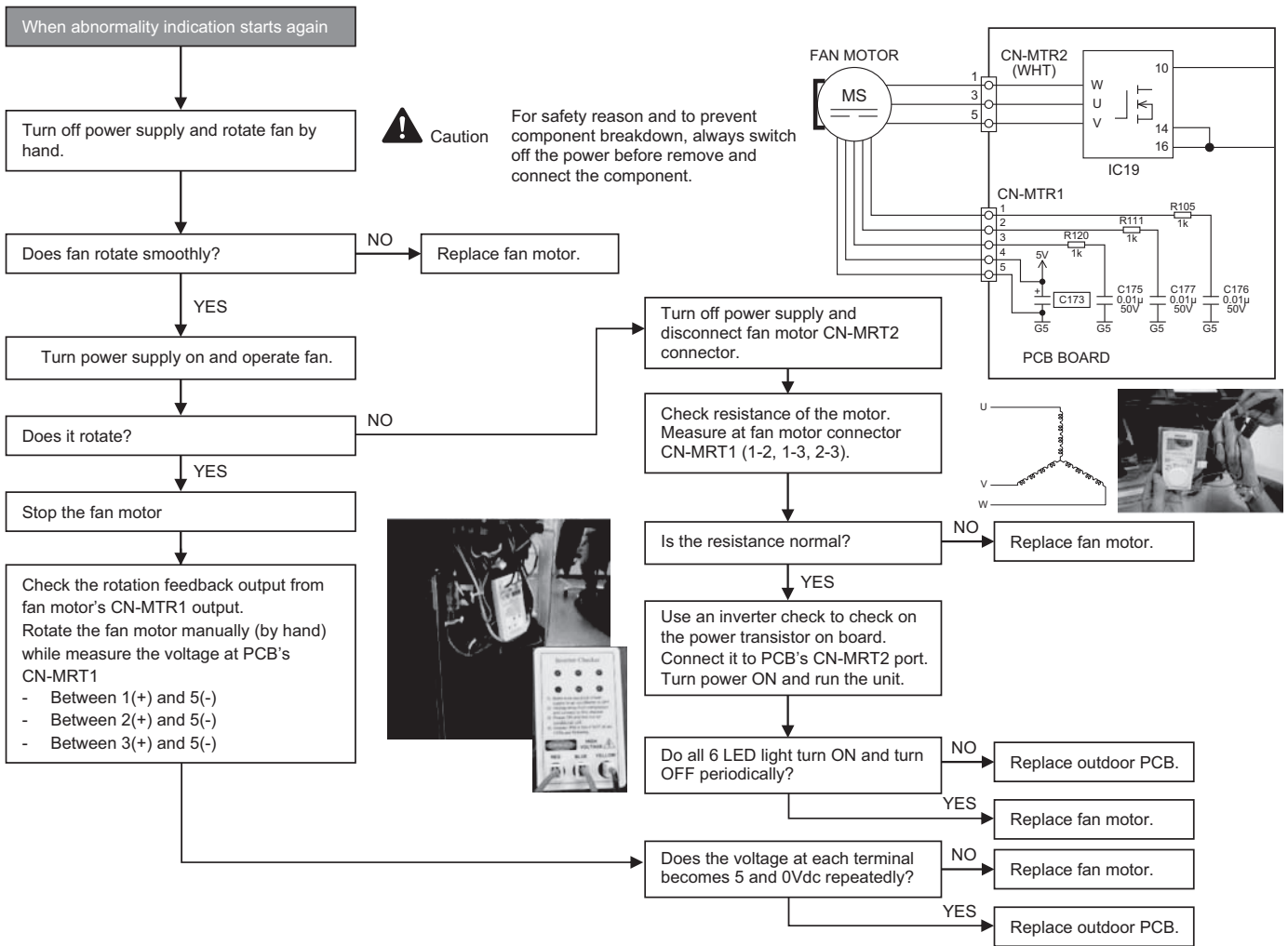

16.4.17 H98 (Error Code Stored in Memory and no alarm is triggered / no TIMER LED flashing)

Malfunction Decision Conditions

- Indoor high pressure is detected when indoor heat exchanger is detecting very high temperature when the unit is operating in heating operation.
- Phenomena: unit is stopping and re-starting very often in heating mode

Malfunction Caused

- Indoor heat exchanger thermistor
- Clogged air filter or heat exchanger
- Over-bent pipe (liquid side)

Troubleshooting

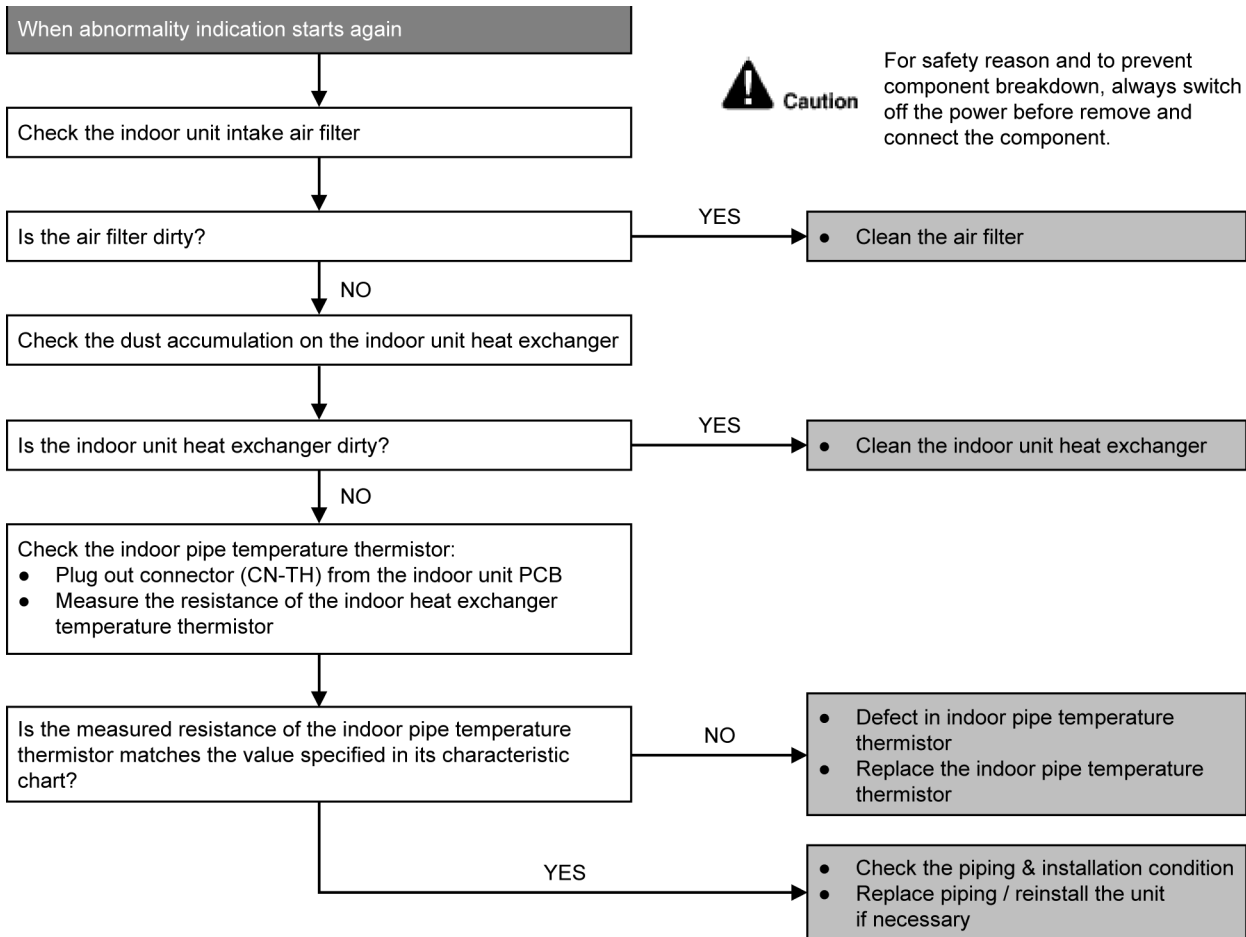

16.4.18 H99 (Indoor Freeze Prevention Protection: Cooling or Soft Dry)

Error Code will not display (no Timer LED blinking) but store in EEPROM

Malfunction Decision Conditions

- Freeze prevention control takes place (when indoor pipe temperature is lower than 2°C)

Malfunction Caused

- Air short circuit at indoor unit
- Clogged indoor unit air filter
- Dust accumulation on the indoor unit heat exchanger
- 2/3 way valve closed
- Faulty indoor unit fan motor
- Refrigerant shortage (refrigerant leakage)
- Clogged expansion valve or strainer
- Faulty indoor pipe temperature sensor
- Faulty indoor unit PCB

Troubleshooting

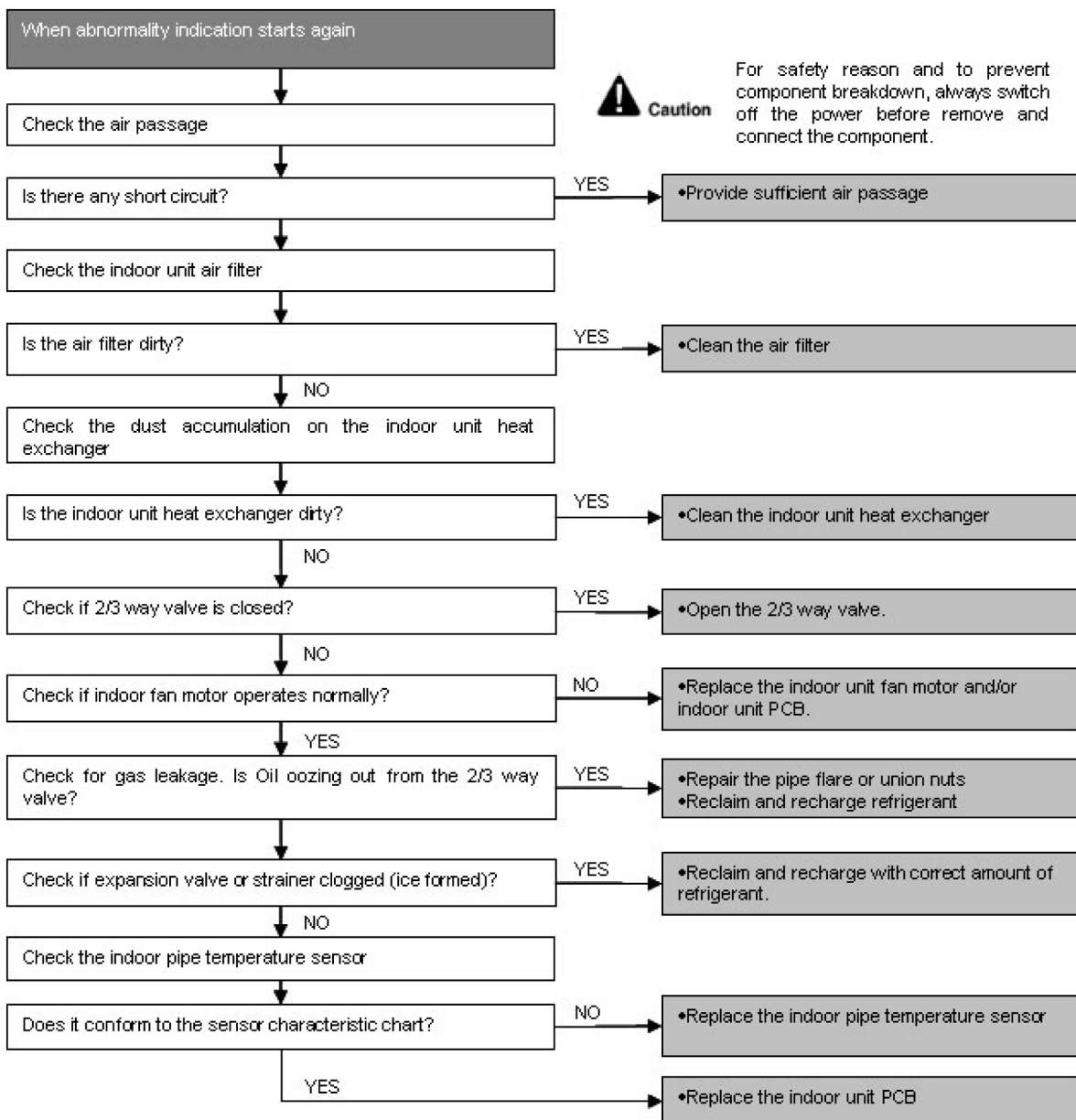

16.4.19 F11 (4-way Valve Switching Failure)

Malfunction Decision Conditions

- When indoor heat exchanger is cold during heating (except deice) or when indoor heat exchanger is hot during cooling and compressor operating, the 4-way valve is detected as malfunction.

Malfunction Caused

- Indoor heat exchanger (pipe) thermistor
- 4-way valve malfunction

Troubleshooting

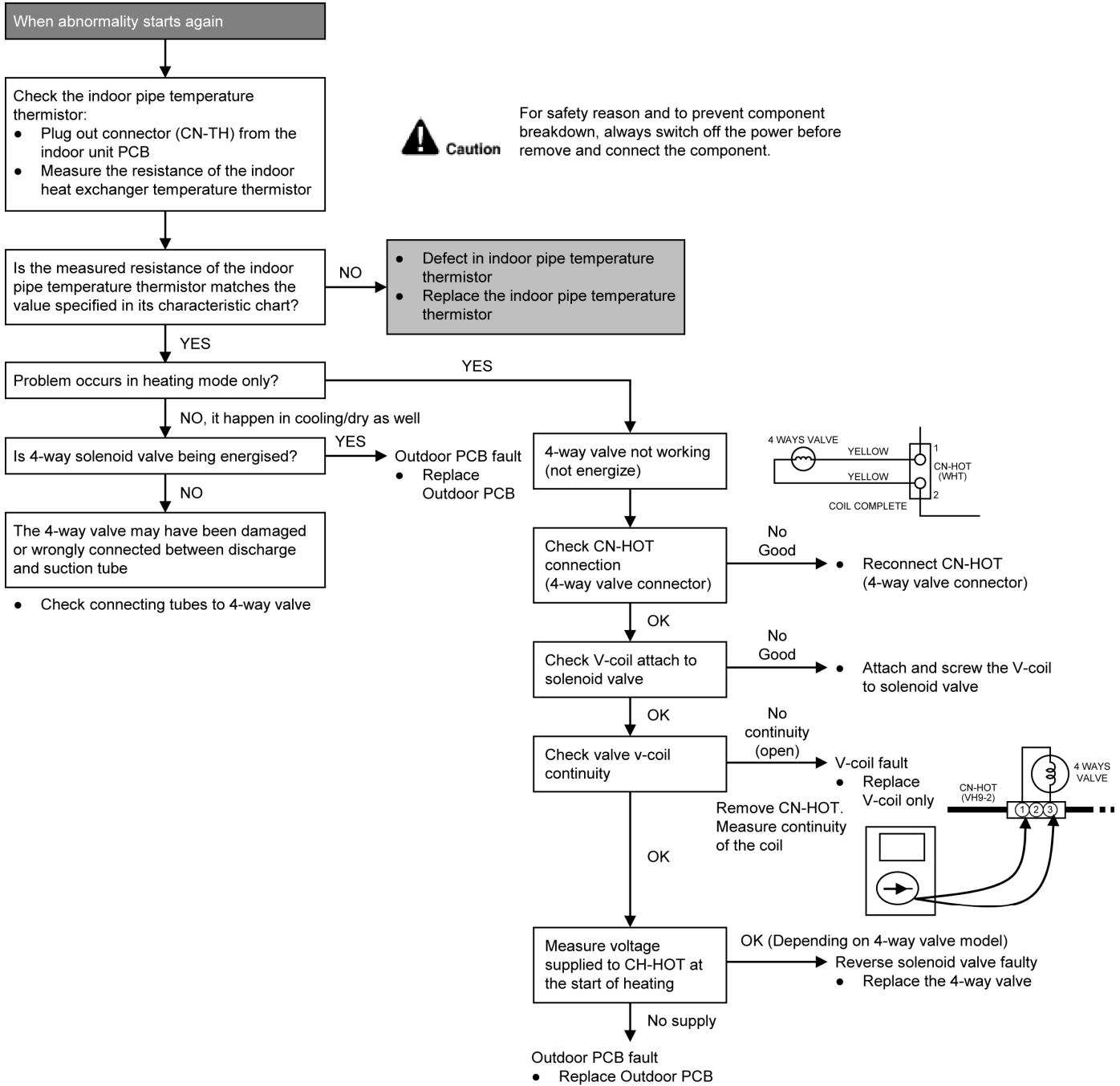

* Check gas side pipe – for hot gas flow in cooling mode

16.4.20 F17 (Indoor Standby Units Freezing Abnormality)

Malfunction Decision Conditions

- When the different between indoor intake air temperature and indoor pipe temperature is above 10°C or indoor pipe temperature is below -1.0°C.

Remark:

When the indoor standby unit is freezing, the outdoor unit transfers F17 error code to the corresponding indoor unit and H39 to other indoor unit(s).

Malfunction Caused

- Wrong wiring connection
- Faulty sensor
- Faulty expansion valve

Troubleshooting

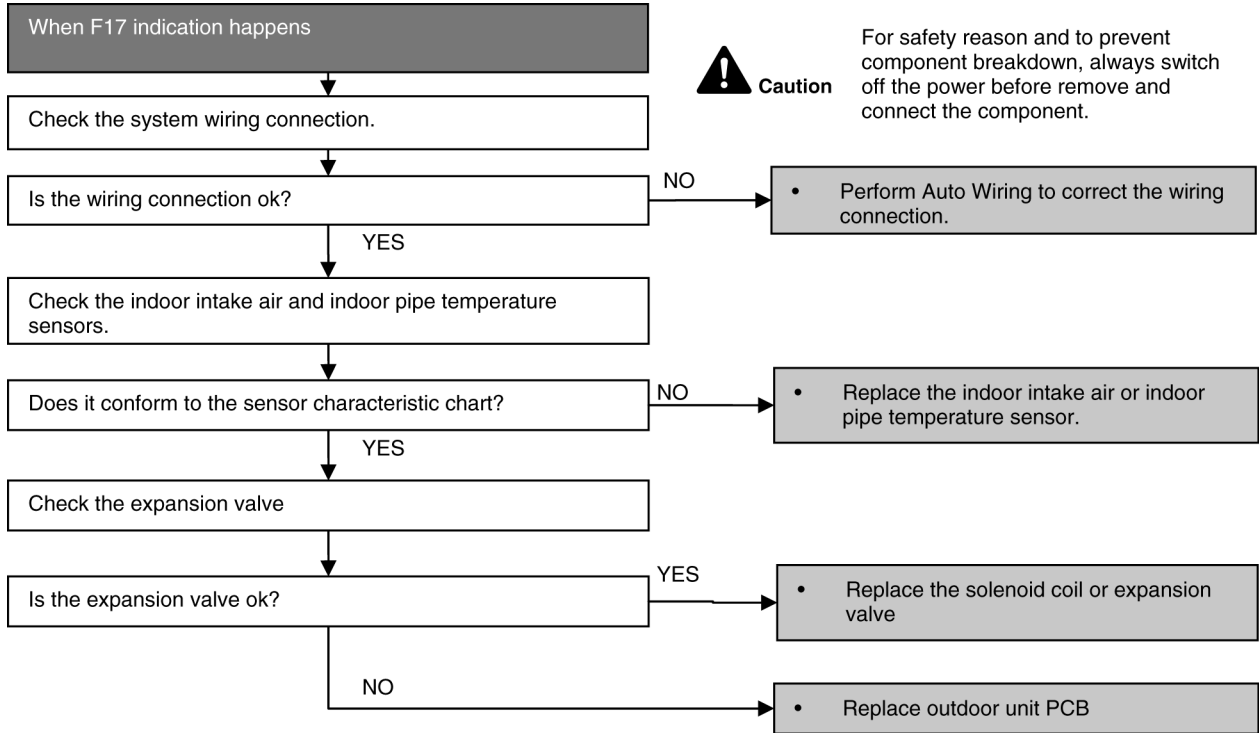

16.4.21 F90 (Power Factor Correction Protection)

Malfunction Decision Conditions

- To maintain DC voltage level supply to power transistor.
- To detect high DC voltage level after rectification.

Malfunction Caused

- During startup and operation of cooling and heating, when Power Factor Correction (PFC) protection circuitry at the outdoor unit main PCB senses abnormal DC voltage level for power transistors.
- When DC voltage detected is LOW, transistor switching will turn ON by controller to push-up the DC level.
- When DC voltage detected is HIGH (391Vdc – 425Vdc), active LOW signal will send by the controller to turn OFF relay RY-C.

Troubleshooting

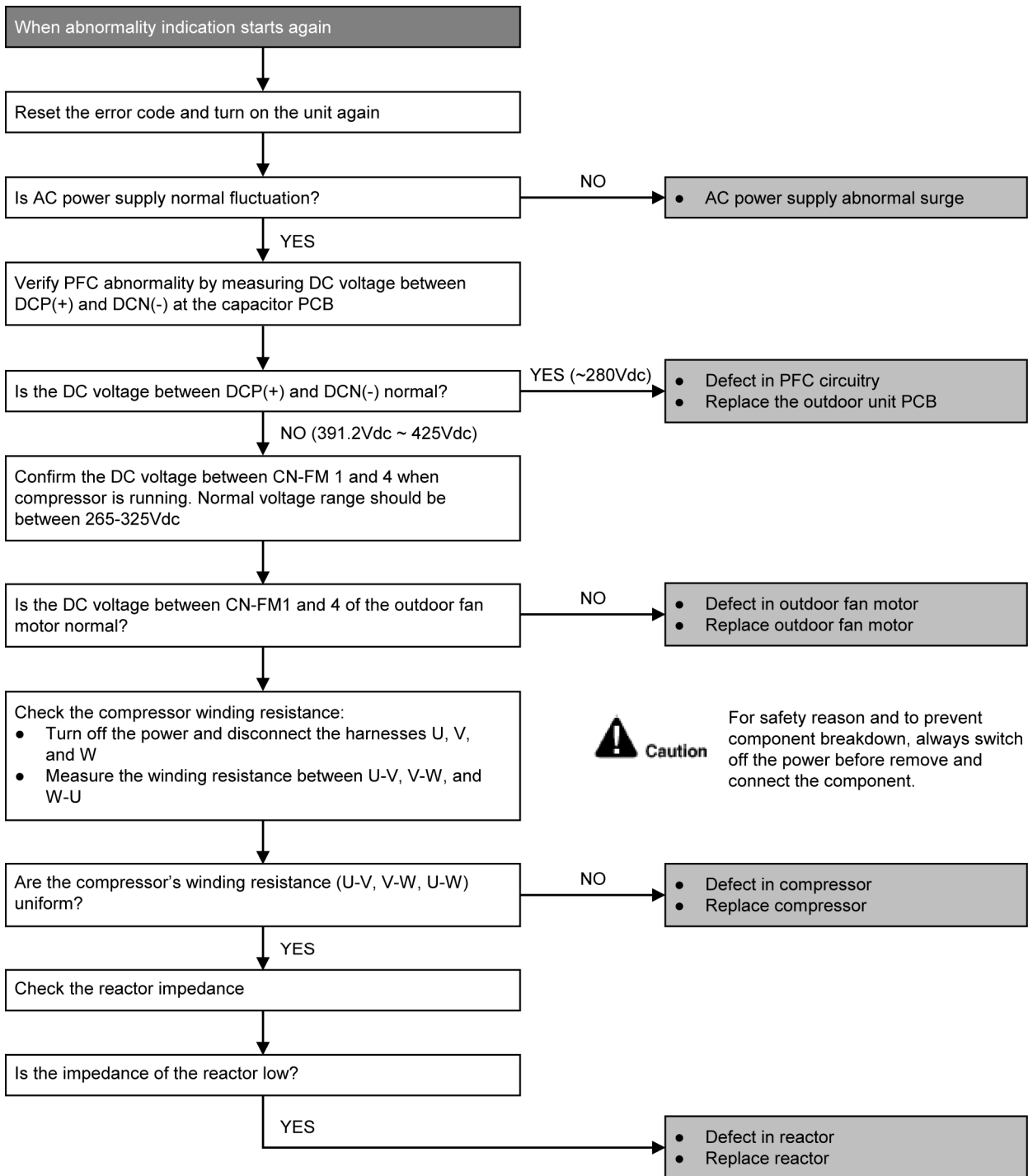

16.4.22 F91 (Refrigeration Cycle Abnormality)

Malfunction Decision Conditions

- The input current is low while the compressor is running at higher than the setting frequency.

Malfunction Caused

- Lack of gas.
- 3-way valve close.

Troubleshooting

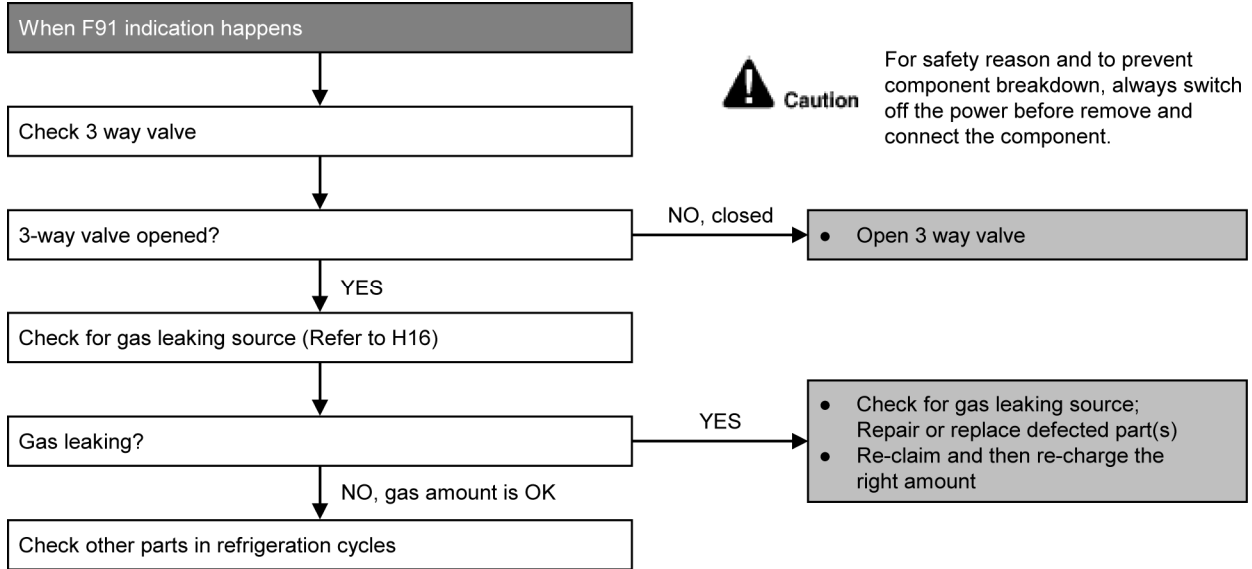

16.4.23 F93 (Compressor Rotation Failure)

Malfunction Decision Conditions

- A compressor rotation failure is detected by checking the compressor running condition through the position detection circuit.

Malfunction Caused

- Compressor terminal disconnect
- Faulty Outdoor PCB
- Faulty compressor

Troubleshooting

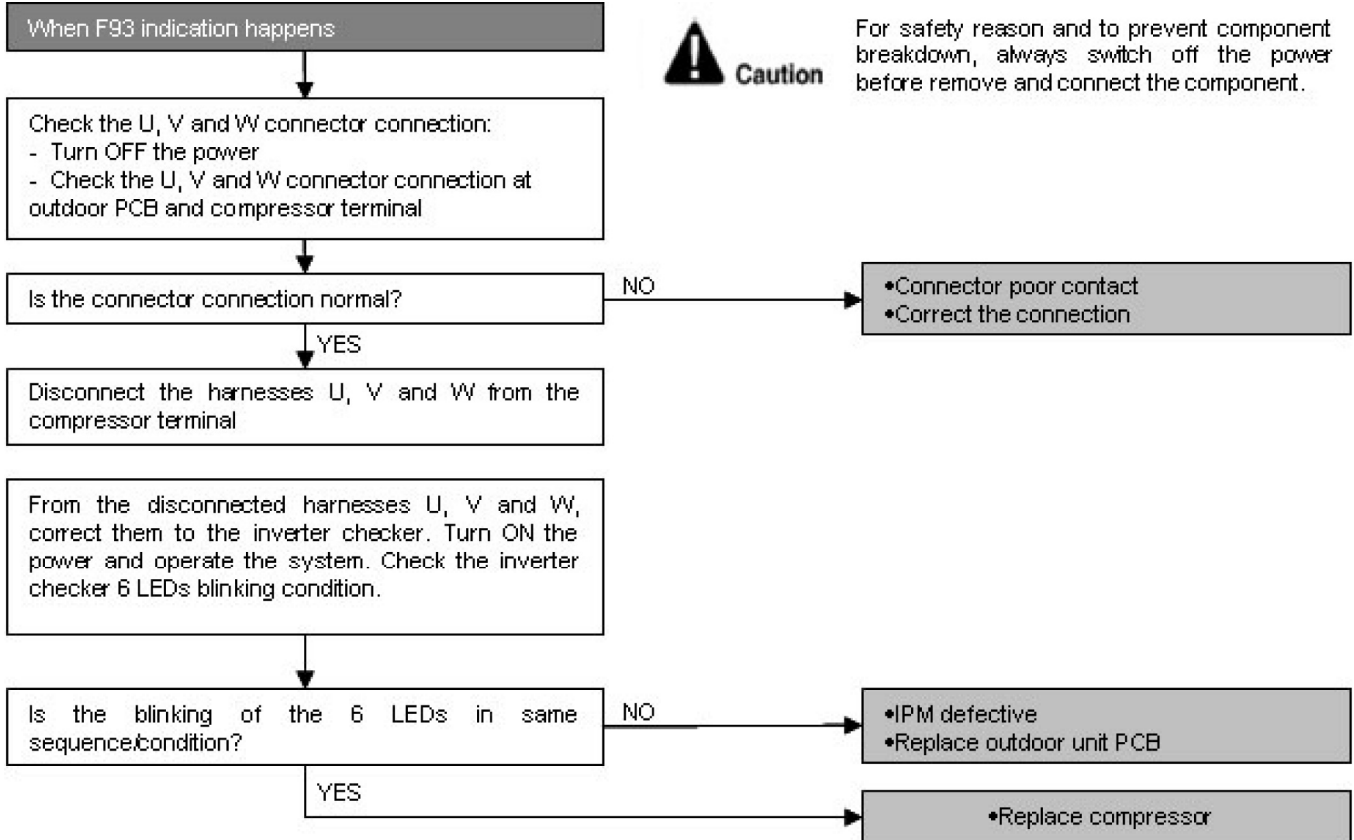

16.4.24 F95 (Outdoor High Pressure Protection: Cooling or Soft Dry)

Malfunction Decision Conditions

- During operation of cooling or soft dry, when outdoor unit heat exchanger high temperature data is detected by the outdoor unit heat exchanger thermistor.

Malfunction Caused

- Outdoor heat exchanger temperature rise due to short-circuit of hot discharge air flow.
- Outdoor heat exchanger temperature rise due to defective of outdoor fan motor.
- Outdoor heat exchange temperature rise due to defective outdoor heat exchanger thermistor.
- Outdoor heat exchanger temperature rise due to defective of outdoor unit PCB.

Troubleshooting

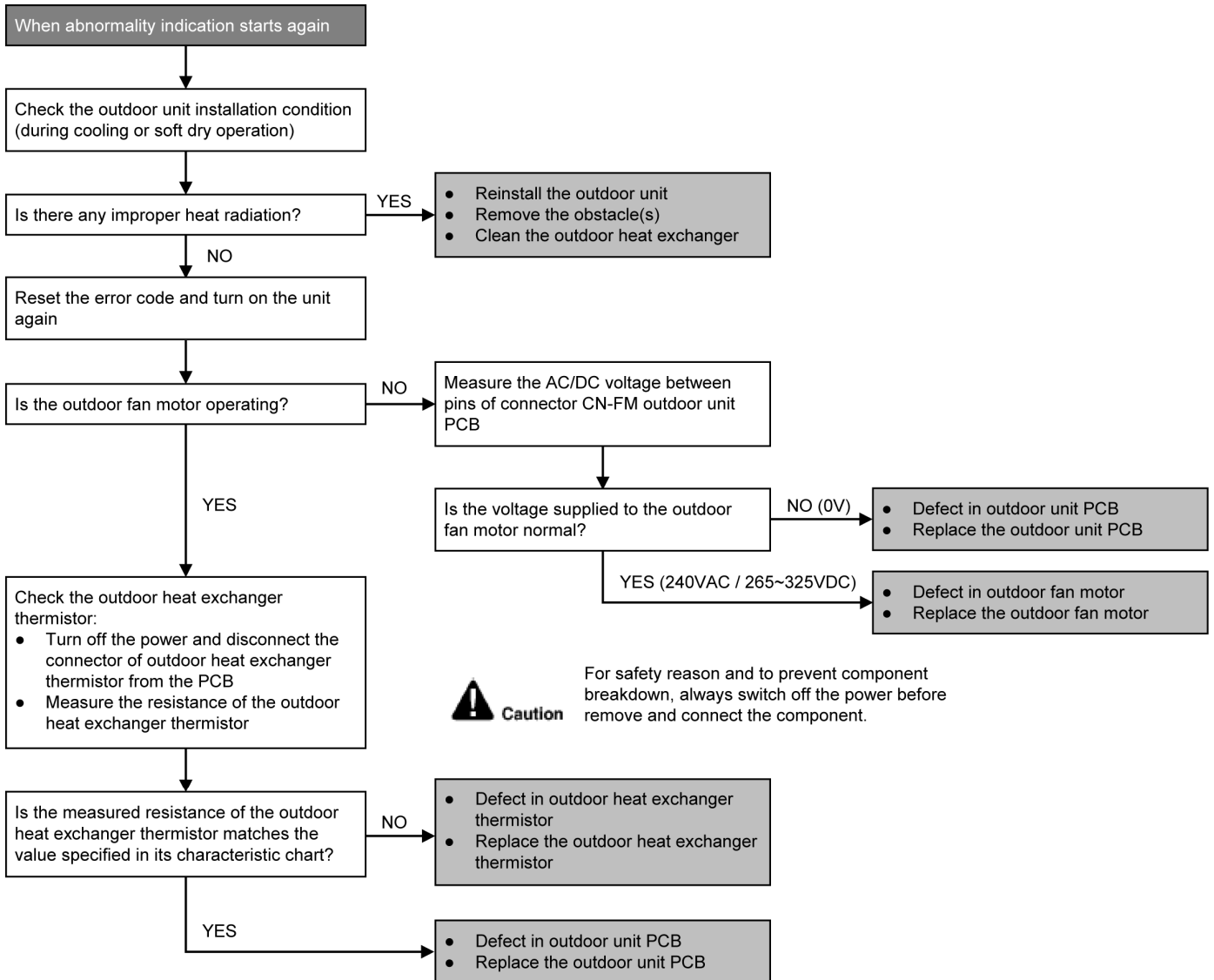

16.4.25 F96 (IPM Overheating)

Malfunction Decision Conditions

- During operating of cooling and heating, when IPM temperature data (100°C) is detected by the IPM temperature sensor.

Multi Models only

- Compressor Overheating: During operation of cooling and heating, when the compressor OL is activated.
- Heat Sink Overheating: During operation of cooling and heating, when heat sink temperature data (90°C) is detected by the heat sink temperature sensor.

Malfunction Caused

- IPM overheats due to short circuit of hot discharge air flow.
- IPM overheats due to defective of outdoor fan motor.
- IPM overheats due to defective of internal circuitry of IPM.
- IPM overheats due to defective IPM temperature sensor.

Multi Models Only

- Compressor OL connector poor contact.
- Compressor OL faulty.

Troubleshooting

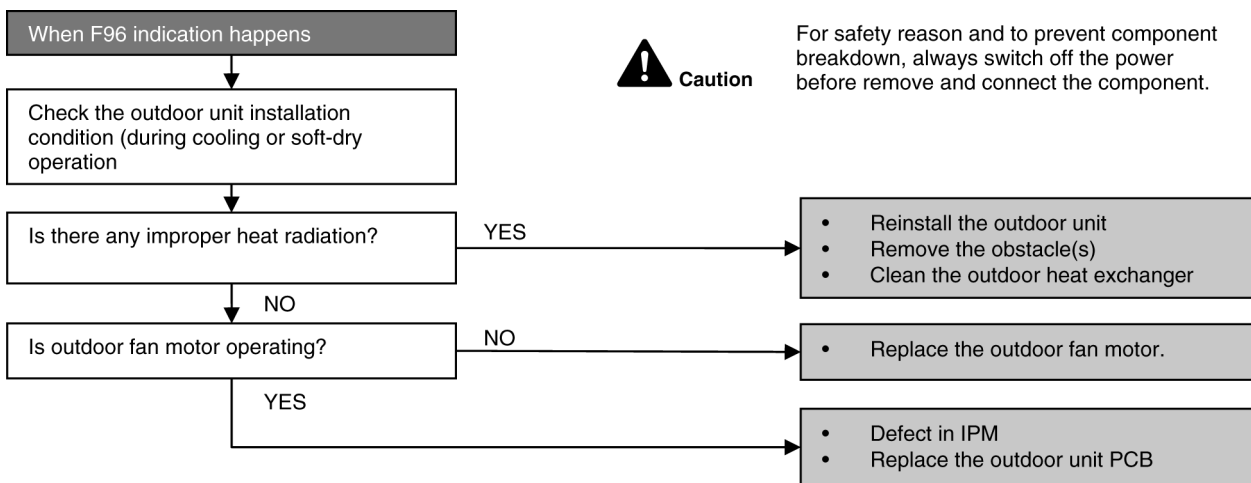

16.4.26 F97 (Compressor Overheating)

Malfunction Decision Conditions

- During operation of cooling and heating, when compressor tank temperature data (112°C) is detected by the compressor tank temperature sensor.

Malfunction Caused

- Faulty compressor tank temperature sensor
- 2/3 way valve closed
- Refrigerant shortage (refrigerant leakage)
- Faulty outdoor unit PCB
- Faulty compressor

Troubleshooting

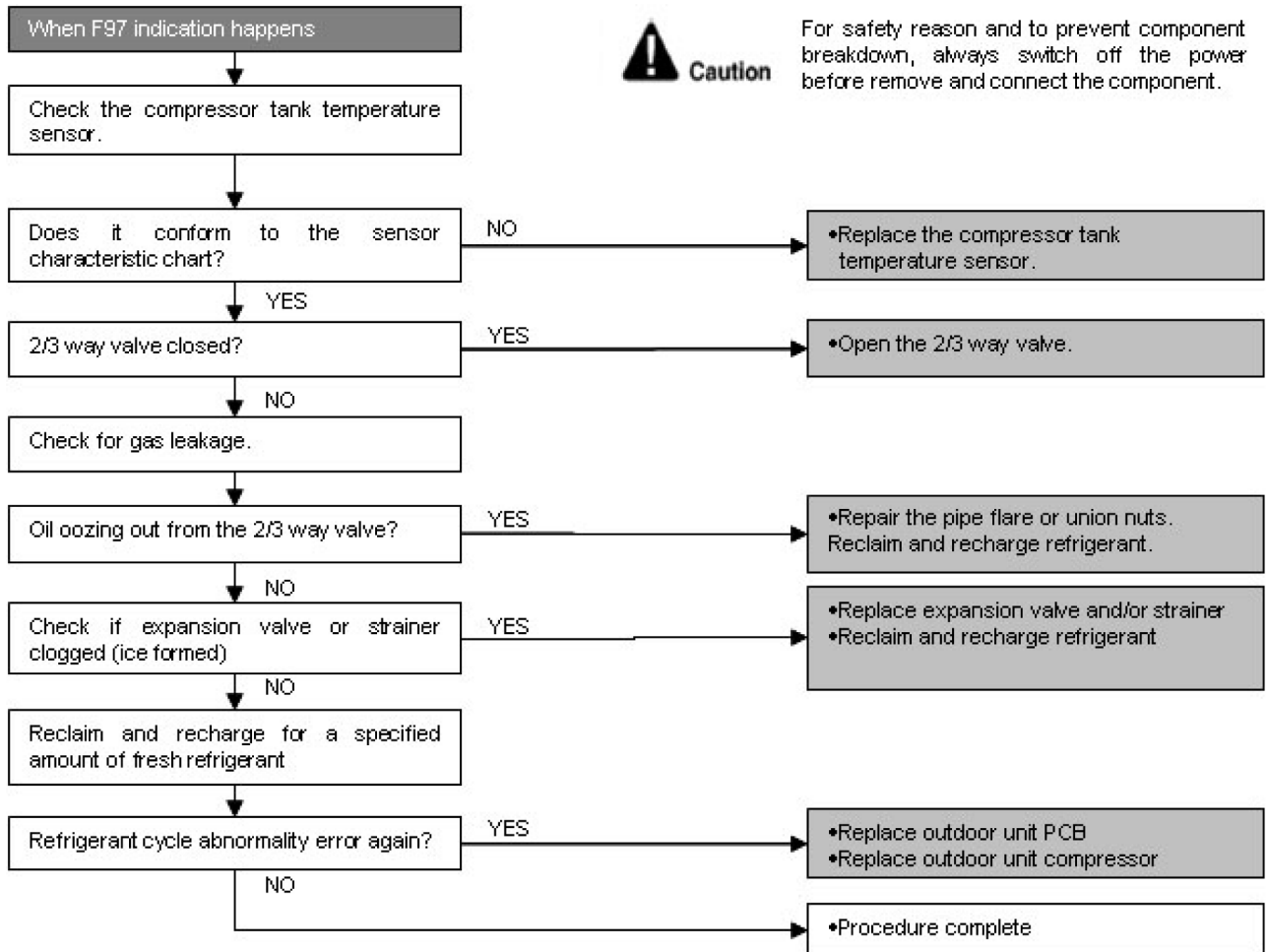

16.4.27 F98 (Input Over Current Detection)

Malfunction Decision Conditions

- During operation of cooling and heating, when an input over-current (X value in Total Running Current Control) is detected by checking the input current value being detected by current transformer (CT) with the compressor running.

Malfunction Caused

- Excessive refrigerant.
- Faulty outdoor unit PCB.

Troubleshooting

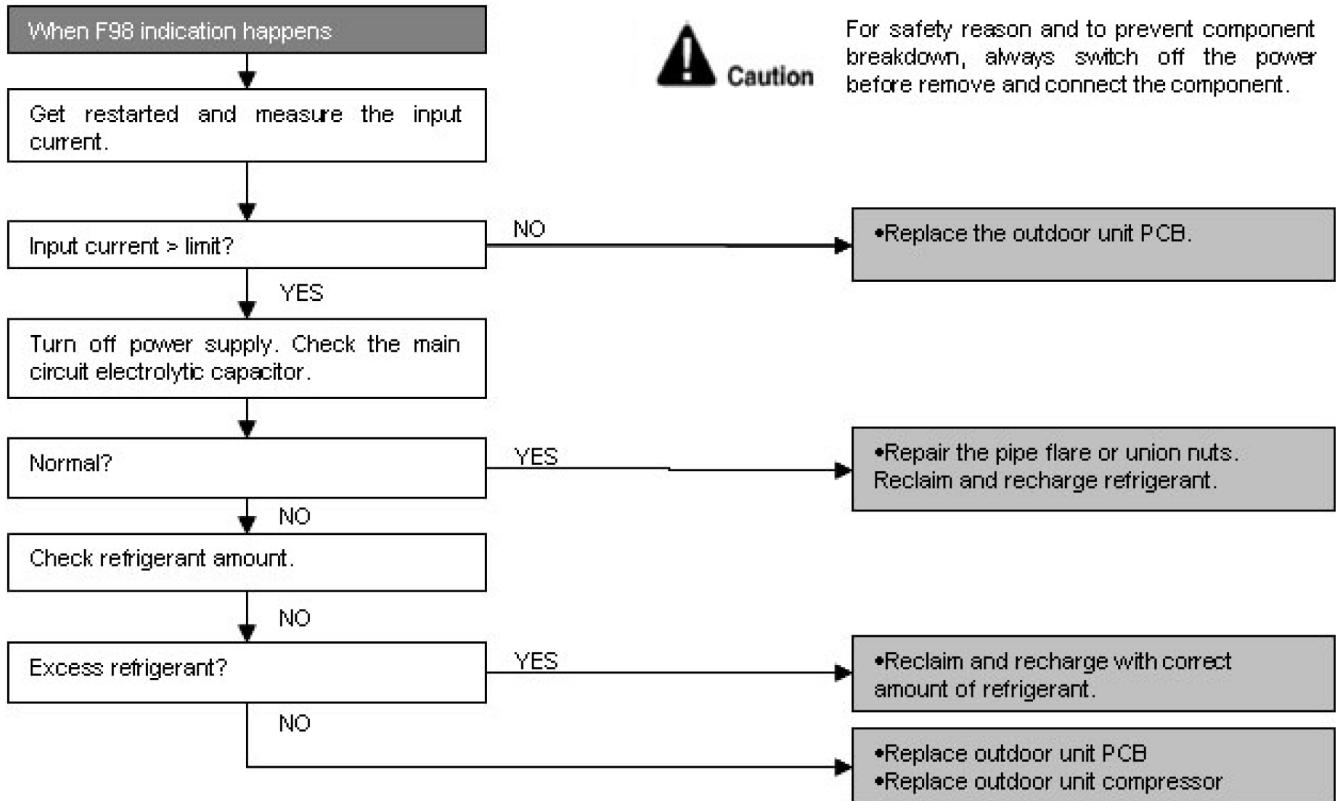

16.4.28 F99 (DC Peak Detection)

Malfunction Decision Conditions

During startup and operation of cooling and heating, when inverter DC peak data is received by the outdoor internal DC Peak sensing circuitry.

Malfunction Caused

- DC current peak due to compressor failure.
- DC current peak due to defective power transistor(s).
- DC current peak due to defective outdoor unit PCB.
- DC current peak due to short circuit.

Troubleshooting

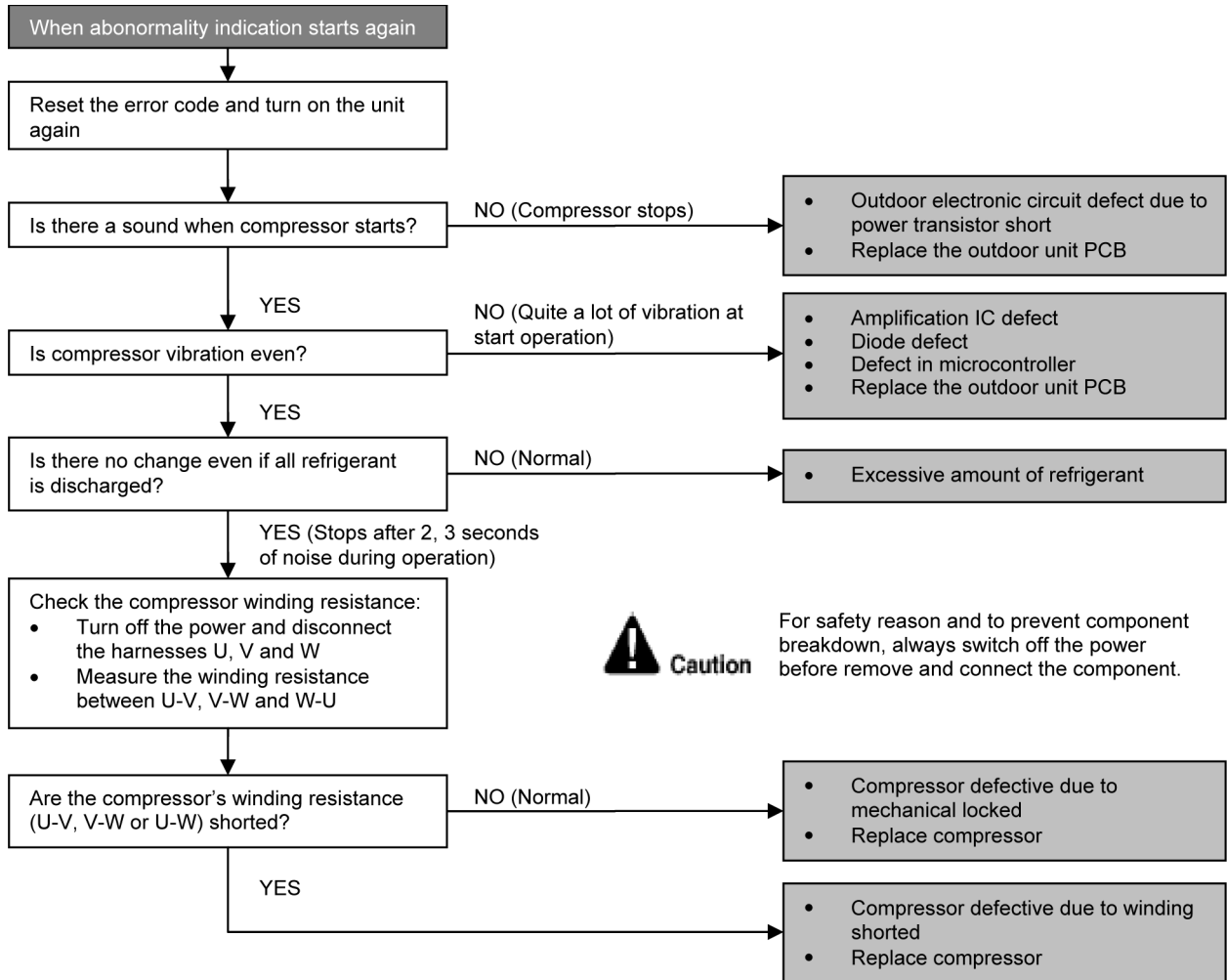

17. Disassembly and Assembly Instructions



WARNING

High Voltage is generated in the electrical parts area by the capacitor. Ensure that the capacitor has discharged sufficiently before proceeding with repair work. Failure to heed this caution may result in electric shocks.

17.1 Indoor Electronic Controllers, Cross Flow Fan and Indoor Fan Motor Removal Procedures

17.1.1 To Remove Front Grille

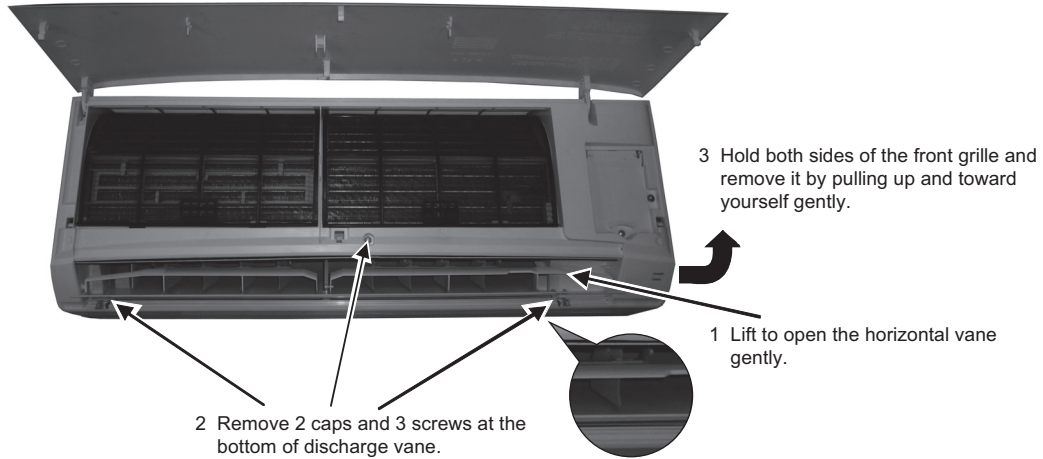

Figure 1

17.1.2 To Remove Power Electronic Controller

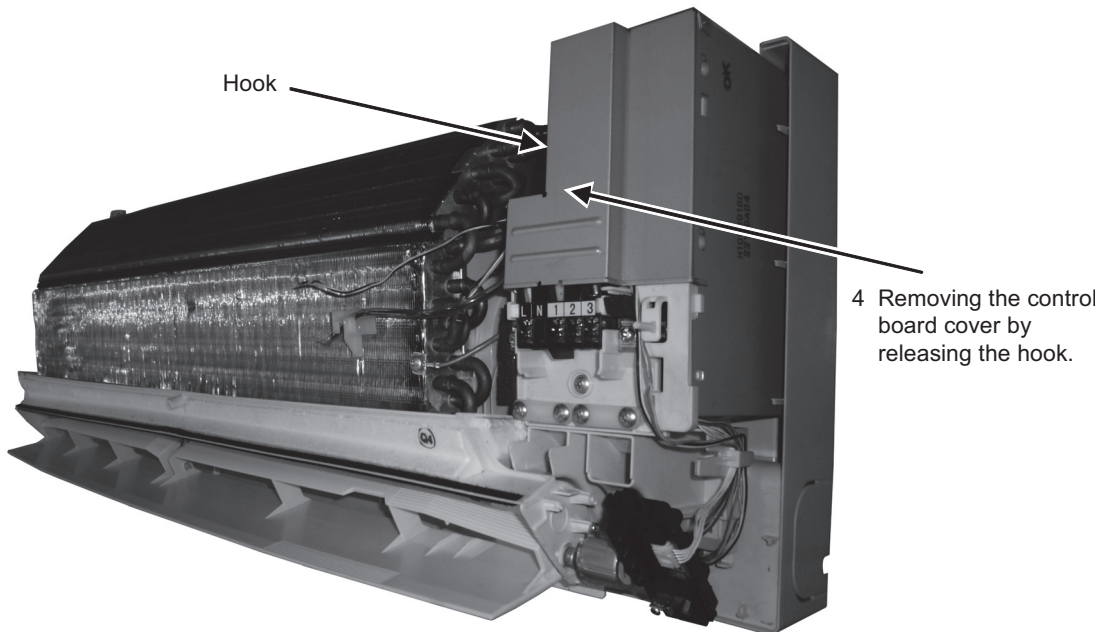

Figure 2

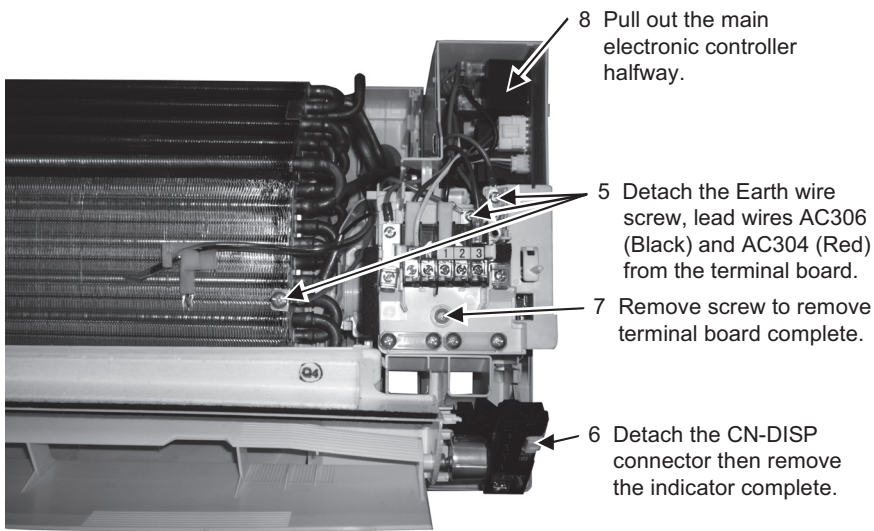

Figure 3

9 Detach connectors as labeled from the electronic controller. Then pull out main controller gently.

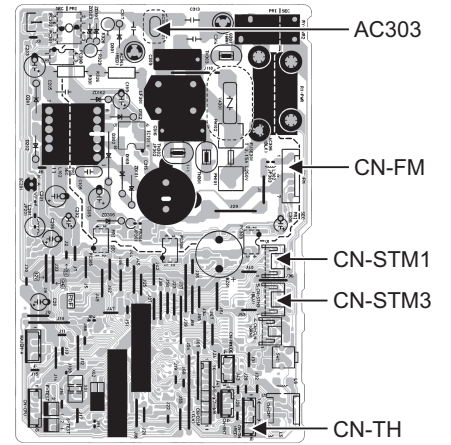
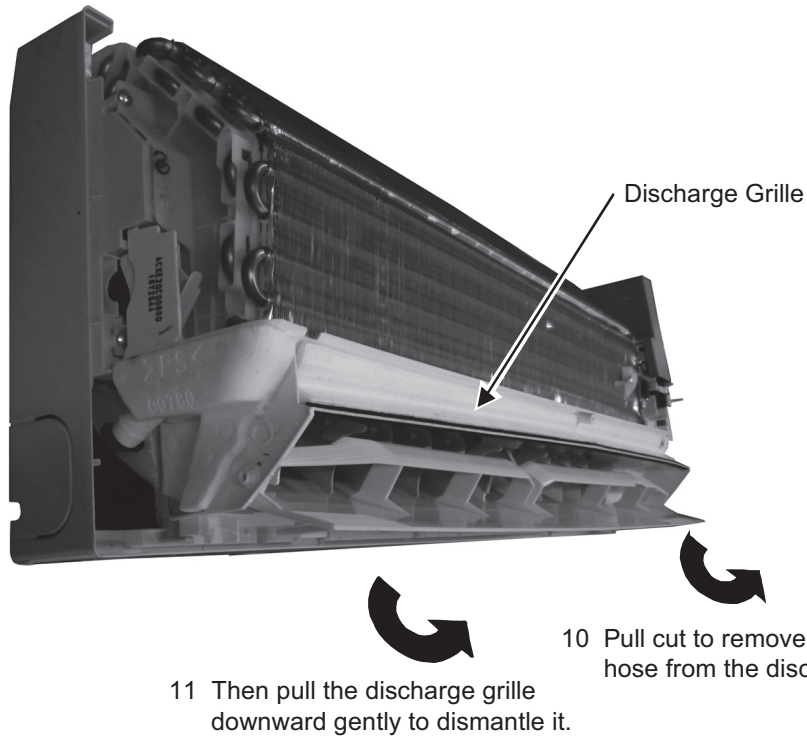

Figure 4

17.1.3 To Remove Discharge Grille



- 10 Pull cut to remove the drain hose from the discharge grille
- 11 Then pull the discharge grille downward gently to dismantle it.

Figure 5

17.1.4 To Remove Control Board

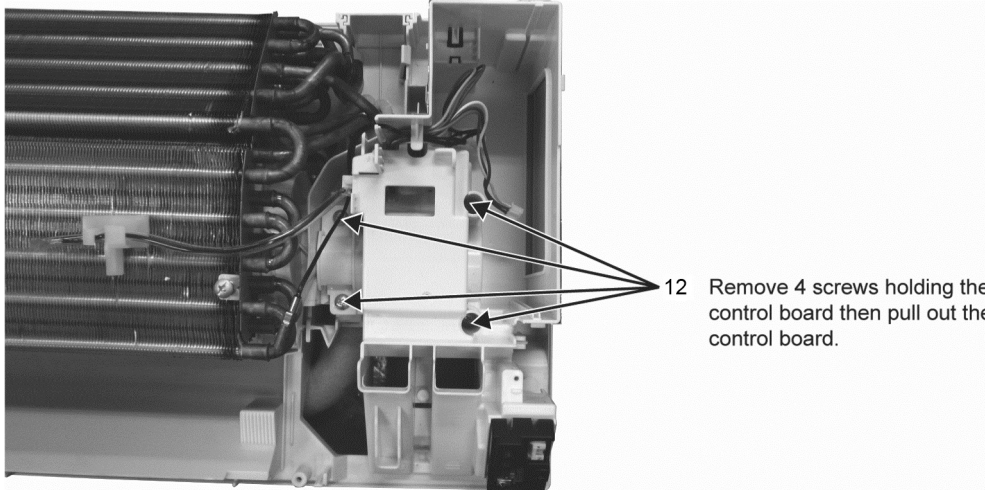

Figure 6

17.1.5 To Remove Cross Flow Fan and Indoor Fan Motor

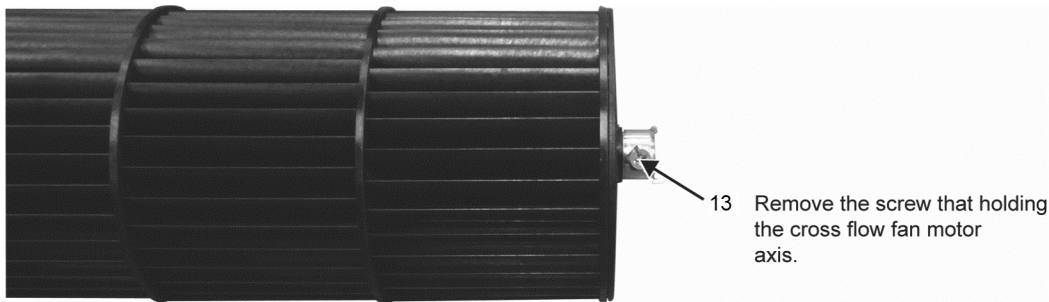

Figure 7

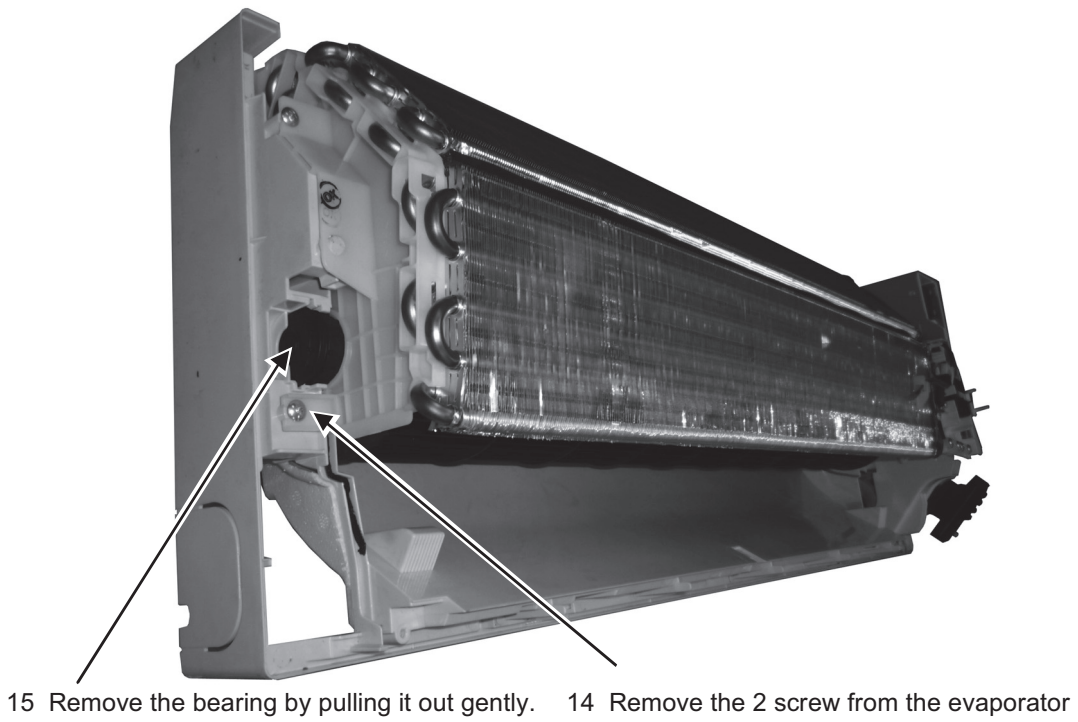

Figure 8

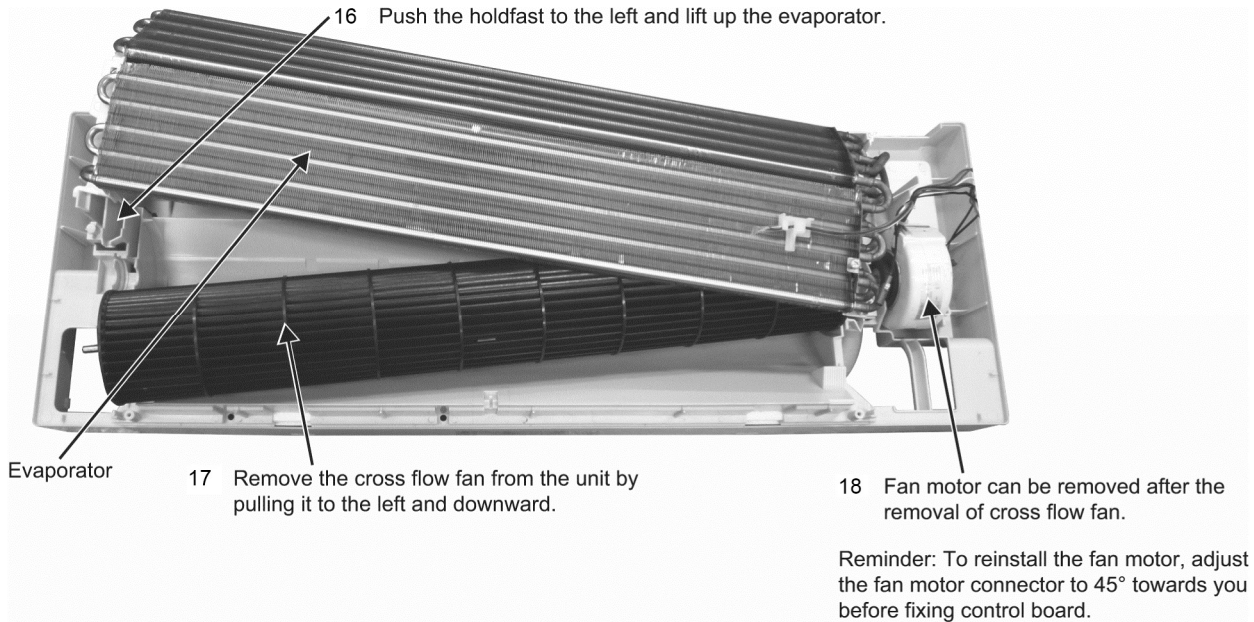

Figure 9

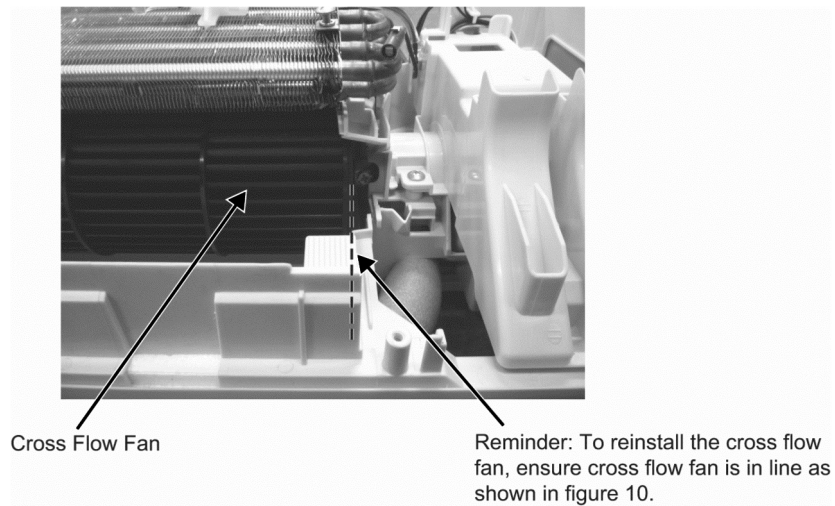

Figure 10

17.2 Outdoor Electronic Controller Removal Procedure

17.2.1 CU-TE20TKE CU-TE25TKE CU-TE35TKE

⚠ Caution! When handling electronic controller, be careful of electrostatic discharge.

- 1 Remove the 5 screws of the Top Panel.

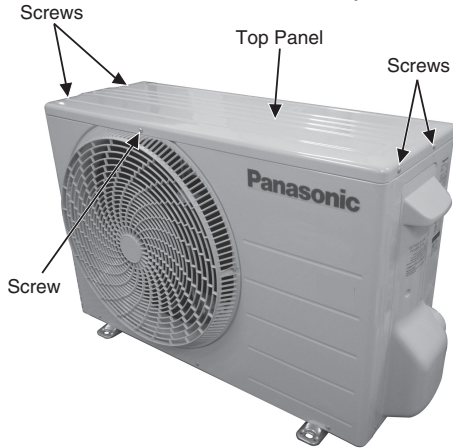

Fig. 1

- 2 Remove the 6 screws of the Front Panel.

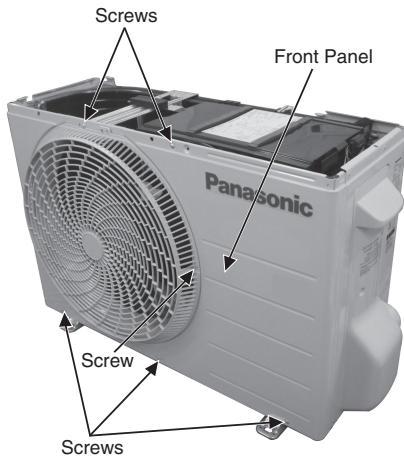

Fig. 2

- 3 Remove the screw of the Terminal Board Cover.

- 4 Remove the Top Cover of the Control Board by 4 hooks.

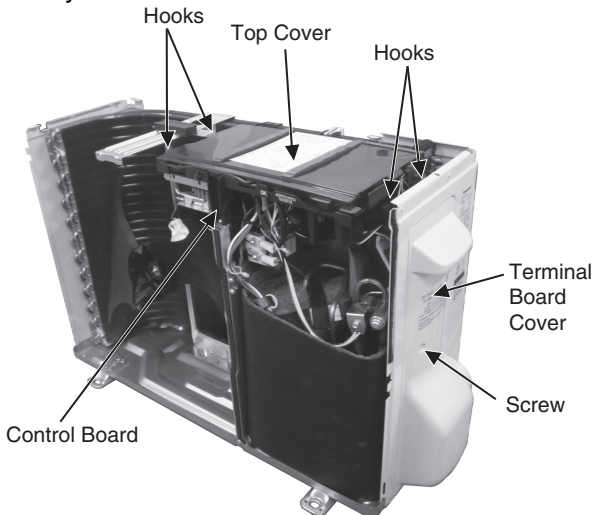

Fig. 3

- 5 Remove the Control Board as follows:

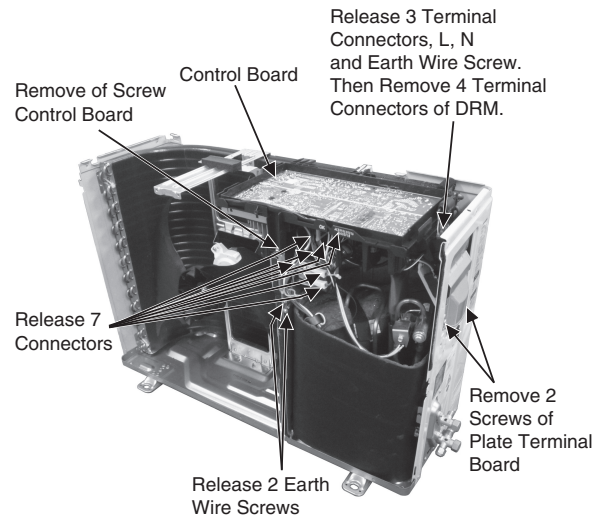

Fig. 4

Remove the Terminal Cover and 3 Terminal Compressor

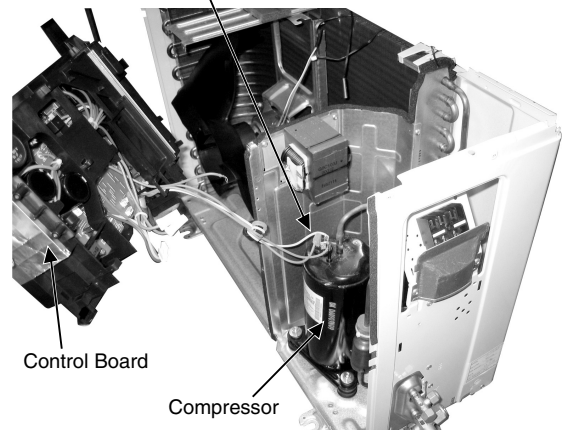

Fig. 5

Electronic Controller Control Board

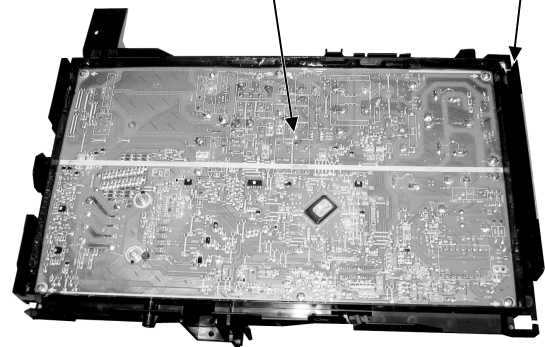

Fig. 6

17.2.2 CU-TE42TKE

⚠ Caution! When handling electronic controller, be careful of electrostatic discharge.

- 1 Remove the 5 screws of the Top Panel.

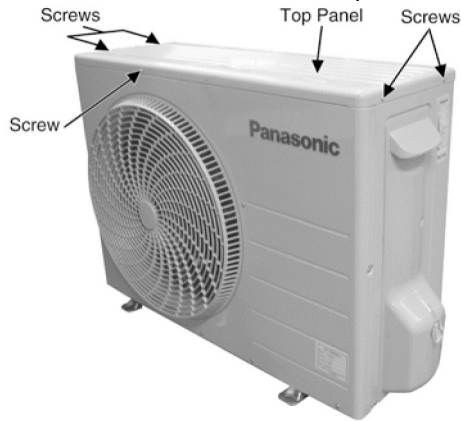

Fig. 1

- 2 Remove the 8 screws of the Front Panel.

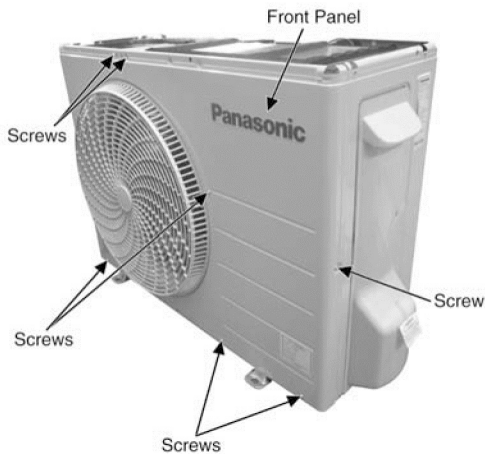

Fig. 2

- 3 Remove the screw of the Terminal Board Cover.
4 Remove the Top Cover of the Control Board by 4 hooks.

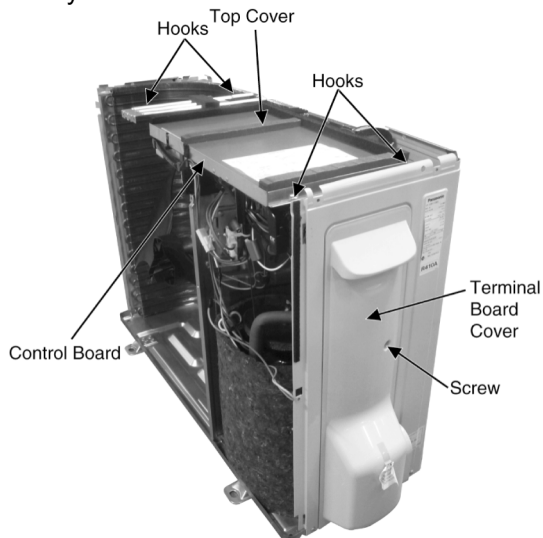

Fig. 3

- 5 Remove the Control Board as follows:

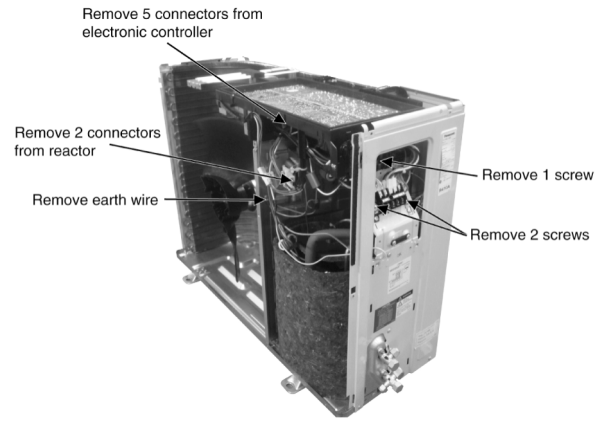

Fig. 4

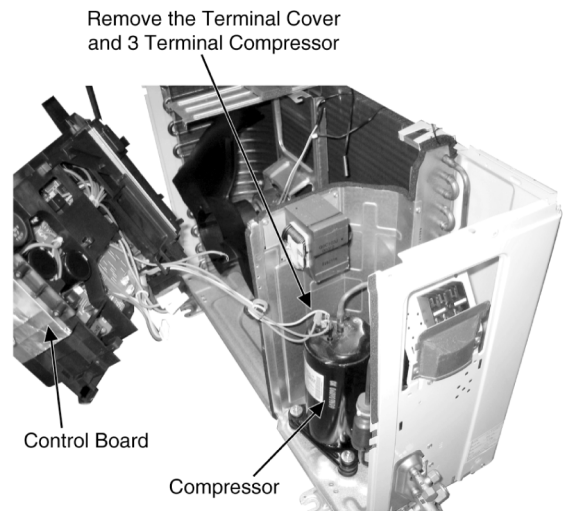

Fig. 5

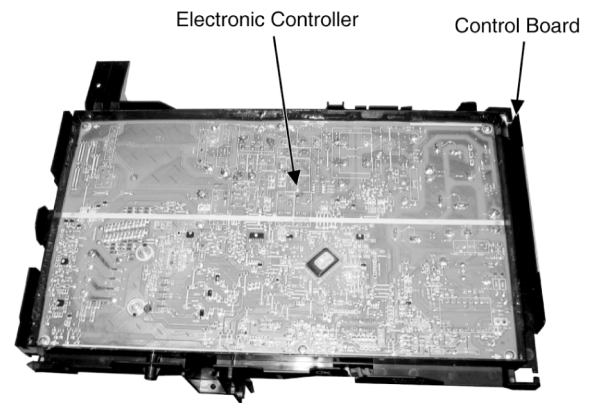

Fig. 6

18. Technical Data

Technical data provided are based on the air conditioner running under free frequency.

18.1 Cool Mode Performance Data

Unit setting: Standard piping length, Hi Fan, Cool mode at 16°C

Voltage: 230V

18.1.1 CS-TE20TKEW CU-TE20TKE

Indoor (°C)		Outdoor DB (°C)																				
DB	WB	-10			-7			0			5			16			25			35		
		TC	SHC	IP	TC	SHC	IP	TC	SHC	IP	TC	SHC	IP	TC	SHC	IP	TC	SHC	IP	TC	SHC	IP
27	19	2161	1977	389	2171	1990	387	2180	1961	389	2118	1973	453	2384	2129	309	2223	2082	410	2000	1921	530
	22	2384	1591	393	2346	1590	428	2357	1586	416	2452	1626	360	2626	1729	296	2436	1634	405	2172	1532	532
23	15.7	1930	1911	416	1945	1925	398	1925	1906	435	1937	1918	424	2148	2127	319	1992	1973	414	1762	1745	530
	18.4	2134	1578	389	2150	1575	376	2164	1585	389	2083	1558	443	2283	1649	311	2174	1627	411	1954	1526	531
20	13.3	1714	1697	476	1699	1682	398	1834	1816	416	1779	1762	434	2021	2001	326	1835	1817	416	1637	1621	529
	15.8	1947	1557	415	1942	1554	394	1931	1535	437	1894	1513	456	2125	1640	319	1979	1577	413	1776	1483	530

(Dry bulb value based on 46% humidity)

18.1.2 CS-TE25TKEW CU-TE25TKE

Indoor (°C)		Outdoor DB (°C)																				
DB	WB	-10			-7			0			5			16			25			35		
		TC	SHC	IP	TC	SHC	IP	TC	SHC	IP	TC	SHC	IP	TC	SHC	IP	TC	SHC	IP	TC	SHC	IP
27	19	2632	2311	491	2644	2325	489	2655	2291	491	2579	2305	572	2903	2488	391	2707	2432	518	2500	2244	670
	22	2903	1859	497	2857	1857	540	2871	1853	526	2986	1900	455	3198	2021	374	2966	1910	512	2645	1790	673
23	15.7	2351	2327	526	2368	2278	503	2345	2257	550	2359	2336	536	2616	2590	404	2426	2331	523	2146	2125	670
	18.4	2599	1844	492	2618	1841	476	2635	1853	492	2536	1820	560	2780	1927	394	2647	1902	519	2379	1784	671
20	13.3	2088	2067	601	2069	2048	503	2233	2211	526	2167	2164	549	2461	2436	412	2235	2212	525	1994	1974	669
	15.8	2372	1820	525	2365	1816	498	2351	1793	552	2306	1768	577	2588	1916	403	2411	1843	523	2162	1733	671

(Dry bulb value based on 46% humidity)

18.1.3 CS-TE35TKEW CU-TE35TKE

Indoor (°C)		Outdoor DB (°C)																				
DB	WB	-10			-7			0			5			16			25			35		
		TC	SHC	IP	TC	SHC	IP	TC	SHC	IP	TC	SHC	IP	TC	SHC	IP	TC	SHC	IP	TC	SHC	IP
27	19	3782	2949	748	3800	2968	744	3815	2924	748	3707	2942	871	4172	3176	595	3890	3104	789	3500	2864	1020
	22	4172	2373	757	4105	2371	823	4125	2365	800	4291	2425	693	4596	2579	569	4262	2437	780	3801	2285	1024
23	15.7	3378	3345	801	3403	2908	765	3369	2880	837	3390	3356	817	3759	3722	614	3487	2975	797	3084	2849	1020
	18.4	3735	2353	748	3762	2349	724	3787	2365	749	3645	2323	853	3995	2460	599	3840	2427	790	3419	2277	1021
20	13.3	3000	2970	916	2973	2695	765	3209	2862	801	3114	2762	836	3537	3501	628	3212	2901	800	2865	2718	1018
	15.8	3408	2322	799	3399	2317	758	3379	2289	841	3314	2256	878	3719	2445	613	3464	2352	796	3108	2211	1021

(Dry bulb value based on 46% humidity)

18.1.4 CS-TE42TKEW CU-TE42TKE

Indoor (°C)		Outdoor DB (°C)																				
DB	WB	-10			-7			0			5			16			25			35		
		TC	SHC	IP	TC	SHC	IP	TC	SHC	IP	TC	SHC	IP	TC	SHC	IP	TC	SHC	IP	TC	SHC	IP
27	19	4421	3213	939	4442	3233	934	4460	3186	939	4333	3205	1093	4878	3460	746	4547	3382	990	4200	3120	1280
	22	4877	2585	950	4799	2583	1033	4823	2577	1004	5016	2642	870	5373	2810	715	4983	2655	978	4443	2489	1285
23	15.7	3949	3910	1005	3979	3167	960	3939	3138	1051	3963	3924	1025	4395	4351	771	4076	3241	1000	3606	3104	1280
	18.4	4367	2564	939	4398	2559	908	4428	2576	939	4261	2531	1070	4671	2680	752	4447	2644	992	3997	2480	1281
20	13.3	3507	3472	1149	3476	2936	961	3752	3117	1005	3641	3009	1049	4134	4093	788	3754	3161	1004	3349	2961	1277
	15.8	3984	2530	1003	3974	2525	961	3950	2493	1055	3874	2458	1102	4347	2664	770	4050	2563	998	3633	2409	1281

(Dry bulb value based on 46% humidity)

TC - Total Cooling Capacity (W)

SHC - Sensible Heat Capacity (W)

IP - Input Power (W)

18.2 Heat Mode Performance Data

Unit setting: Standard piping length, Hi Fan, Heat mode at 30°C

Voltage: 230V

18.2.1 CS-TE20TKEW CU-TE20TKE

Indoor (°C)	Outdoor WB (°C)									
	-15		-7		2		7		12	
	TC	IP	TC	IP	TC	IP	TC	IP	TC	IP
24	1637	839	1928	876	2510	908	2496	681	2657	678
20	1639	794	2140	870	2610	930	2700	680	2764	678
16	1545	752	2185	833	2601	885	2854	679	2930	676

18.2.2 CS-TE25TKEW CU-TE25TKE

Indoor (°C)	Outdoor WB (°C)									
	-15		-7		2		7		12	
	TC	IP	TC	IP	TC	IP	TC	IP	TC	IP
24	1802	888	2433	1077	2856	996	3051	811	3248	807
20	1805	840	2700	1070	2970	1020	3300	810	3379	807
16	1701	795	2757	1024	2959	971	3488	809	3581	805

18.2.3 CS-TE35TKEW CU-TE35TKE

Indoor (°C)	Outdoor WB (°C)									
	-15		-7		2		7		12	
	TC	IP	TC	IP	TC	IP	TC	IP	TC	IP
24	2527	1208	2974	1379	3558	1240	3586	1072	3817	1066
20	2530	1143	3300	1370	3700	1270	4000	1070	3971	1066
16	2385	1082	3369	1312	3687	1209	4100	1069	4209	1064

18.2.4 CS-TE42TKEW CU-TE42TKE

Indoor (°C)	Outdoor WB (°C)									
	-15		-7		2		7		12	
	TC	IP	TC	IP	TC	IP	TC	IP	TC	IP
24	3089	1528	3514	1731	4526	1787	4623	1372	4921	1365
20	3094	1446	3900	1720	4930	1830	5000	1370	5119	1365
16	2916	1369	3982	1647	4689	1742	5285	1369	5426	1362

TC - Total Cooling Capacity (W)

IP - Input Power (W)

19. Service Data

Service data provided are based on the air conditioner running under rated frequency during forced cooling / forced heating mode.

19.1 Cool Mode Outdoor Air Temperature Characteristic

Condition

- Indoor room temperature: 27°C Dry Bulb/19°C Wet Bulb
- Unit setting: Standard piping length, forced cooling at 16°C, Hi fan
- Compressor frequency: Rated for cooling operation
- Piping length: 5m
- Voltage: 230V

19.1.1 CS-TE20TKEW CU-TE20TKE

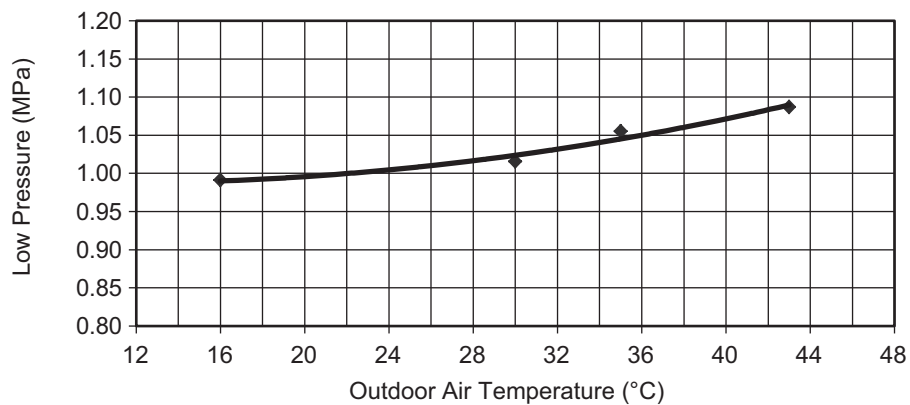
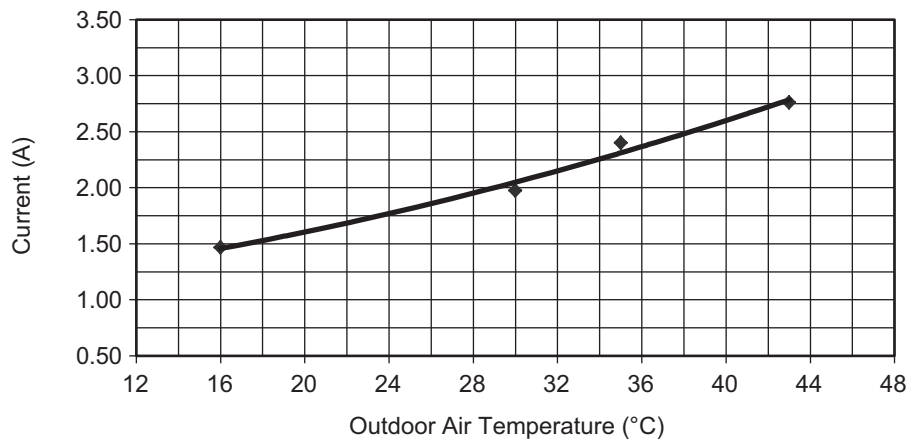
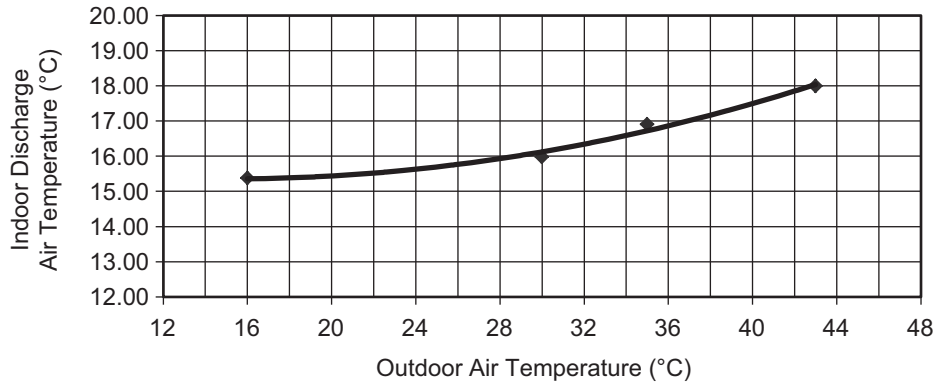

19.1.2 CS-TE25TKEW CU-TE25TKE

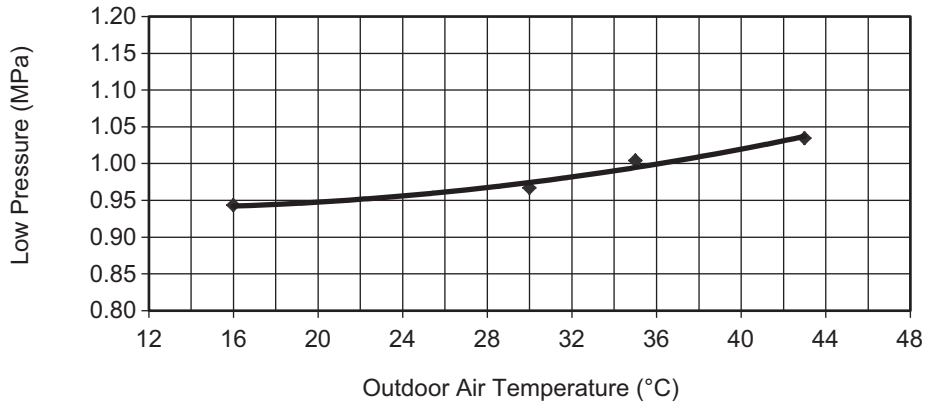
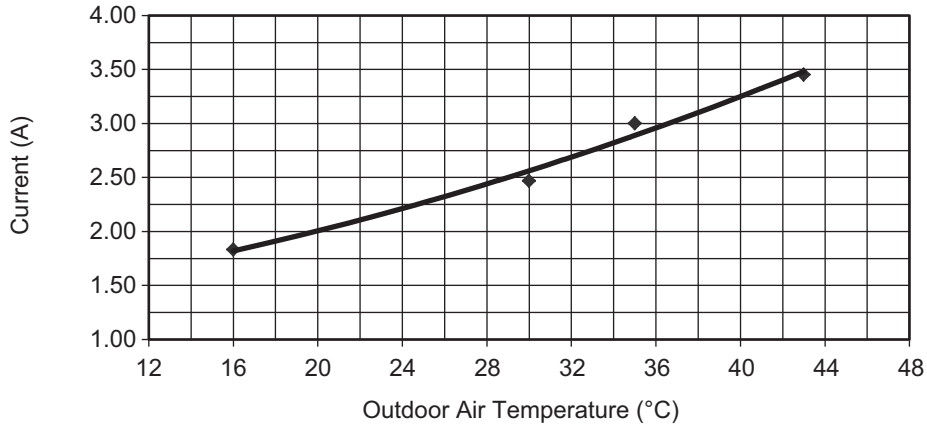
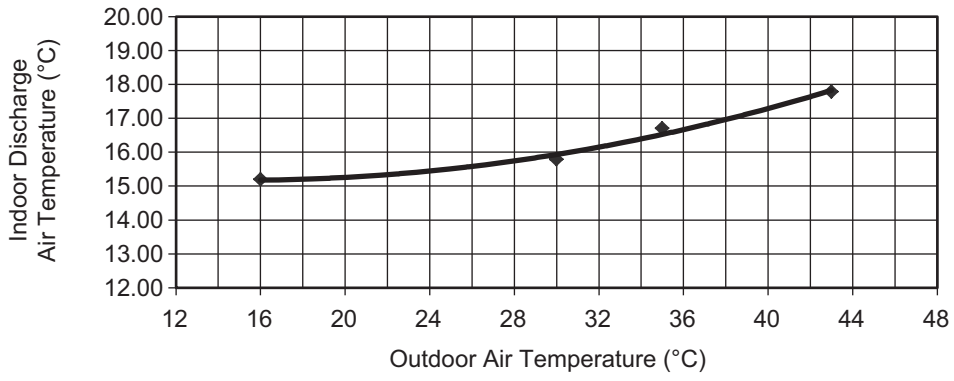

19.1.3 CS-TE35TKEW CU-TE35TKE

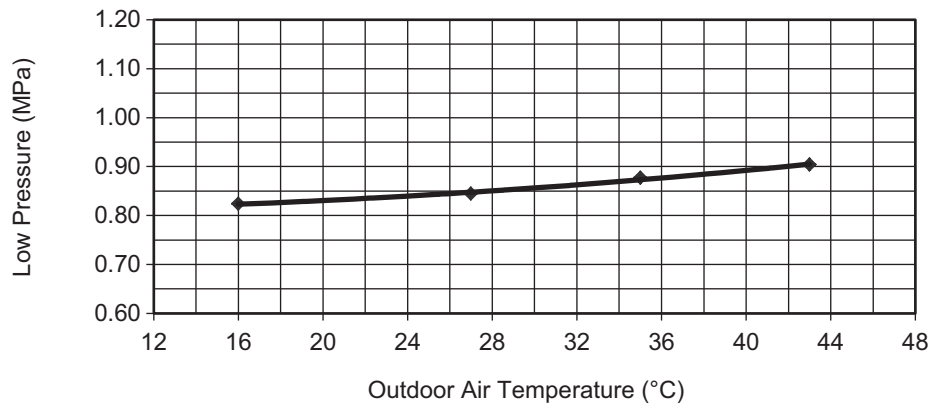
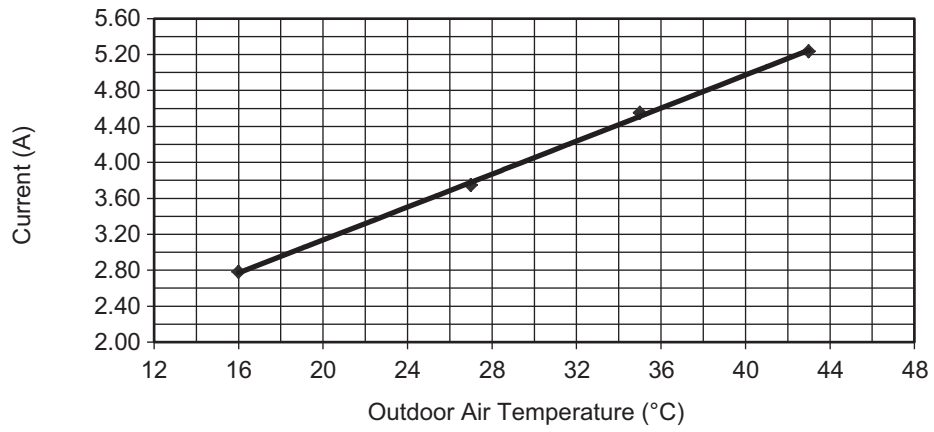
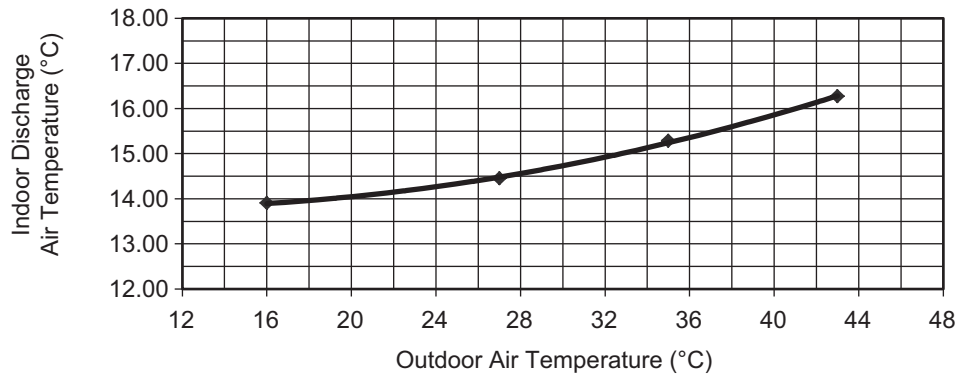

19.1.4 CS-TE42TKEW CU-TE42TKE

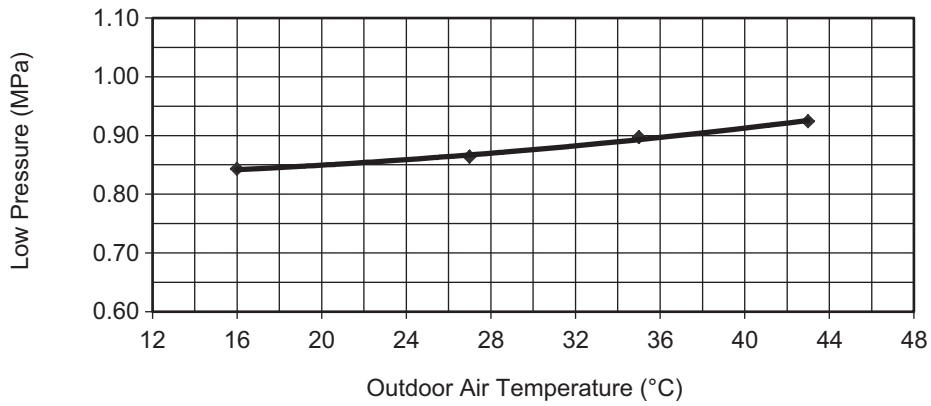
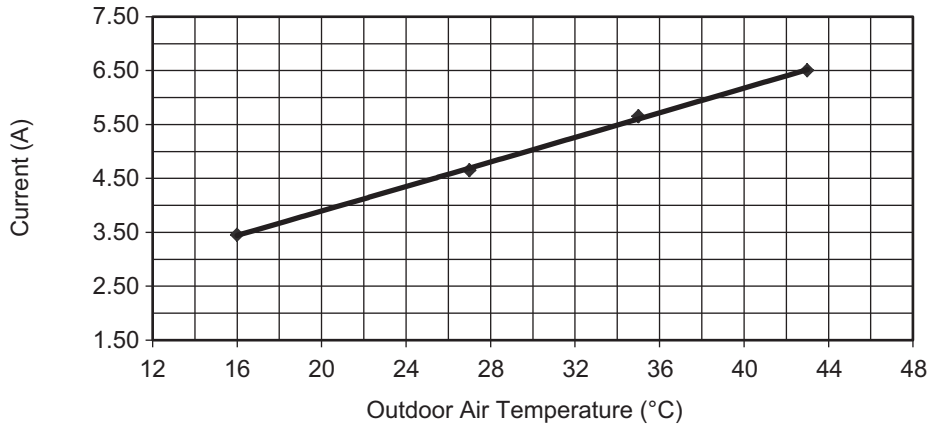
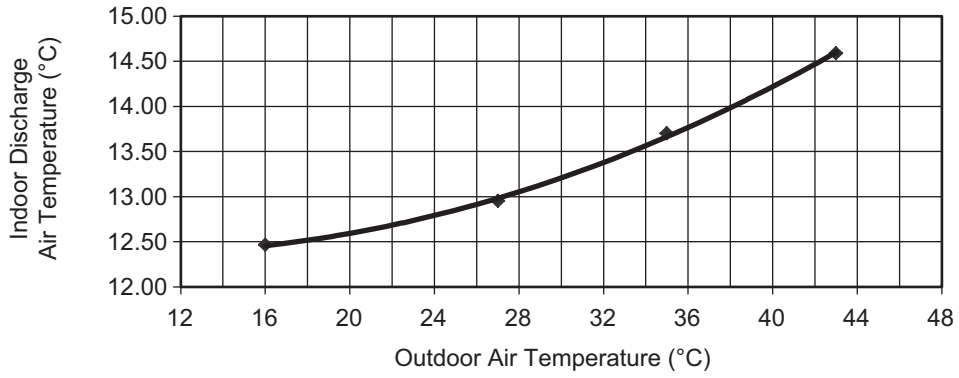

19.2 Heat Mode Outdoor Air Temperature Characteristic

Condition

- Indoor room temperature: 20°C Dry Bulb/ -°C Wet Bulb
- Unit setting: Standard piping length, forced heating at 30°C, Hi fan
- Compressor frequency: Rated for Heating operation
- Piping length: 5m
- Voltage: 230V

19.2.1 CS-TE20TKEW CU-TE20TKE

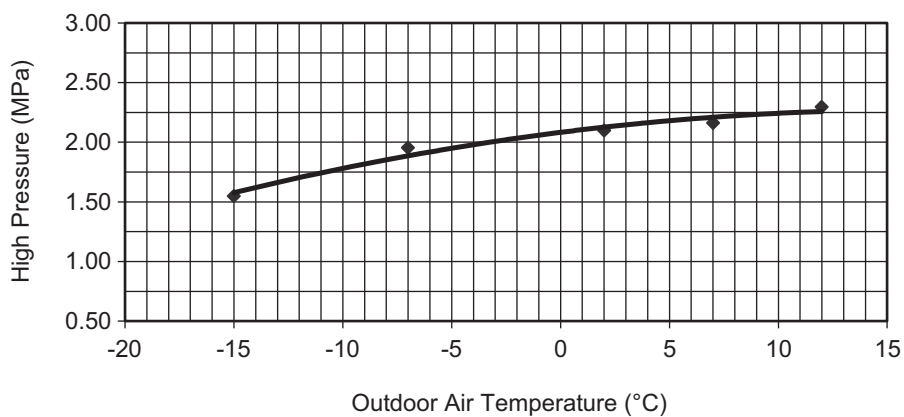
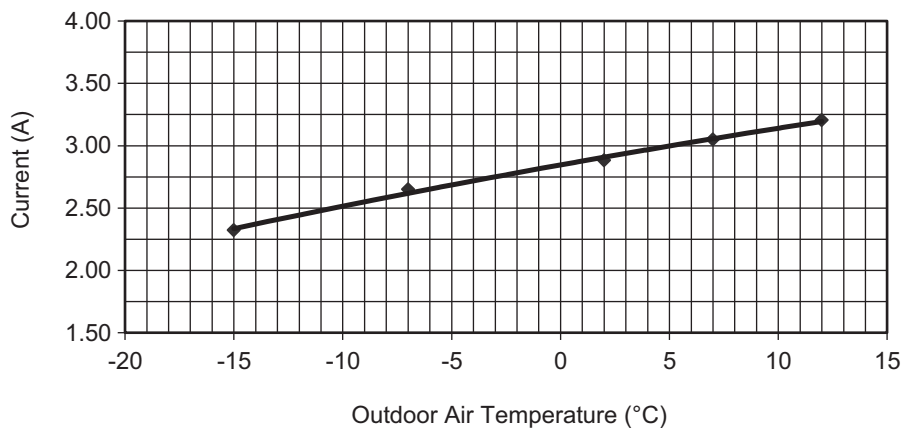
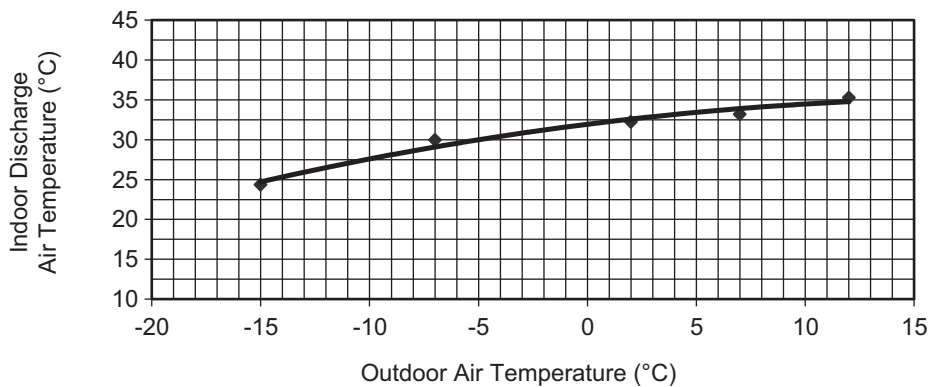

19.2.2 CS-TE25TKEW CU-TE25TKE

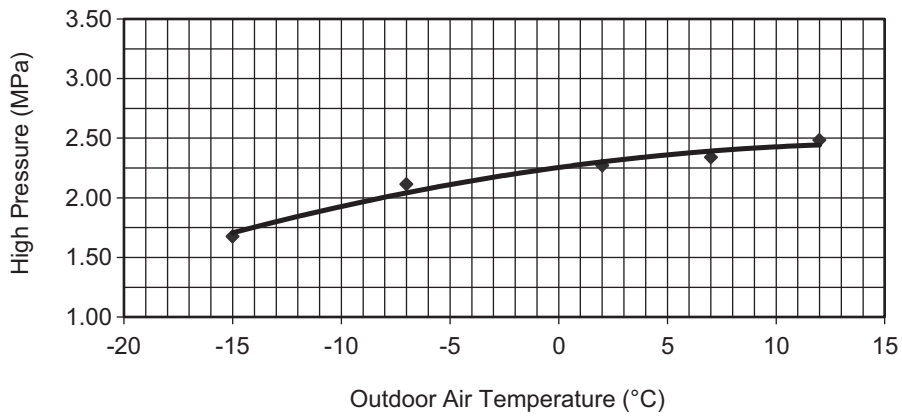
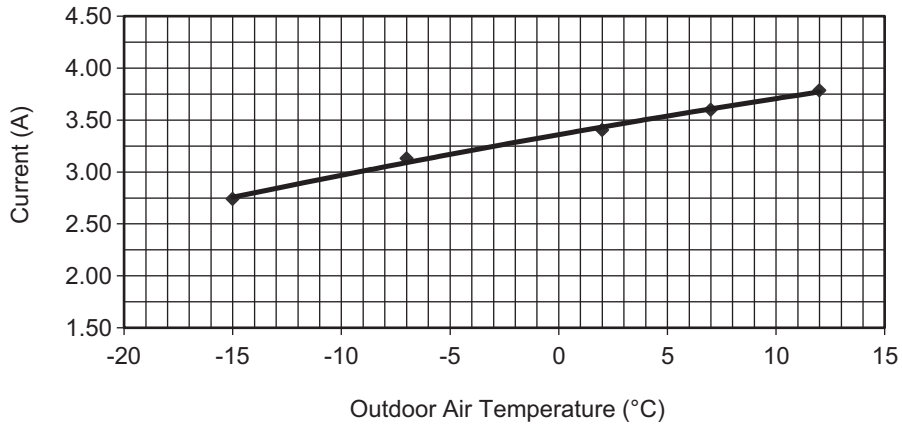
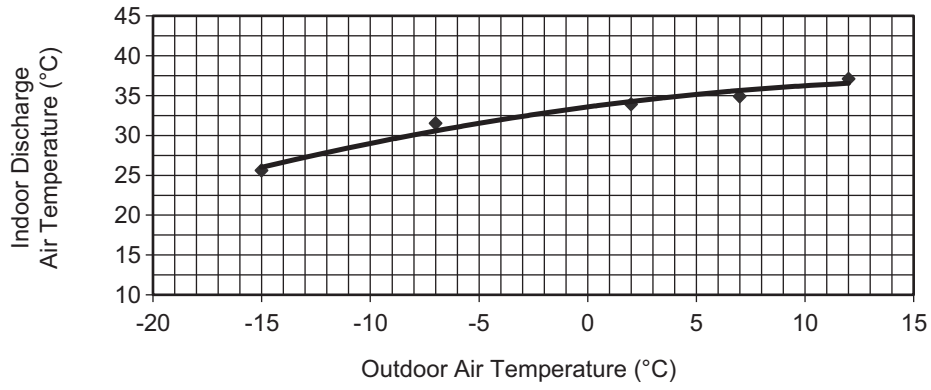

19.2.3 CS-TE35TKEW CU-TE35TKE

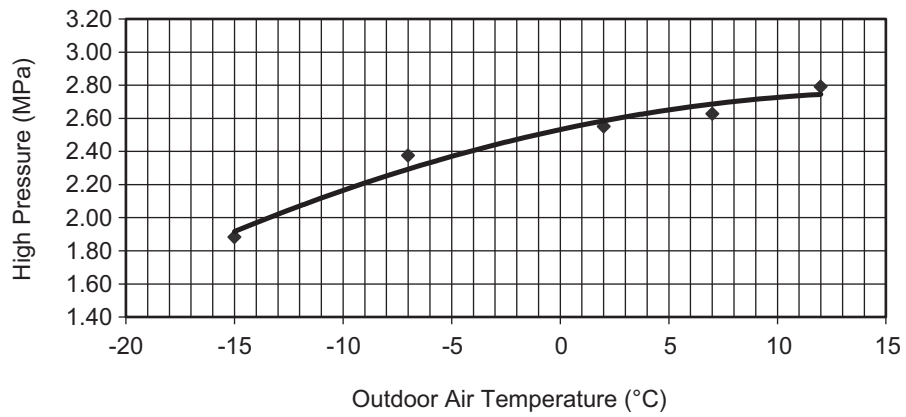
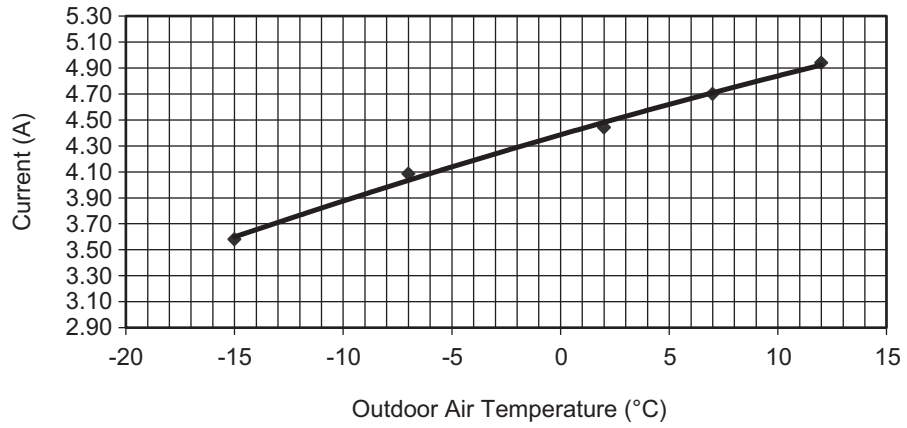
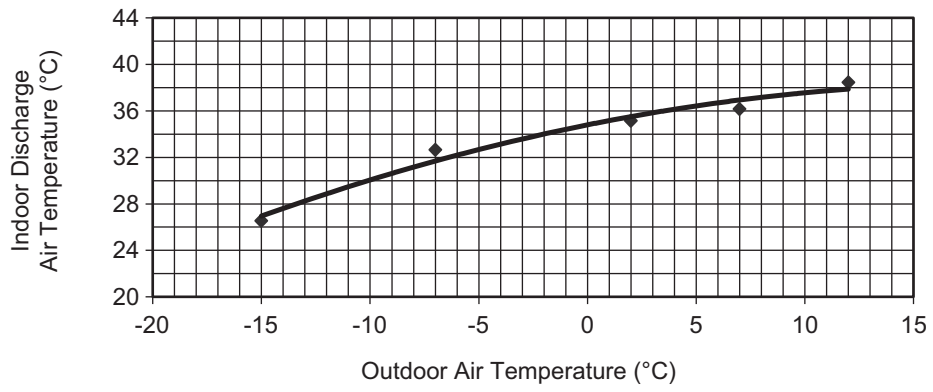

19.2.4 CS-TE42TKEW CU-TE42TKE

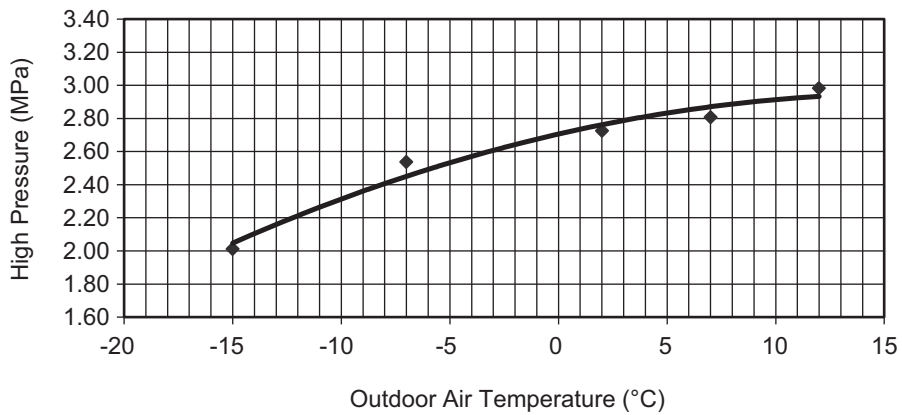
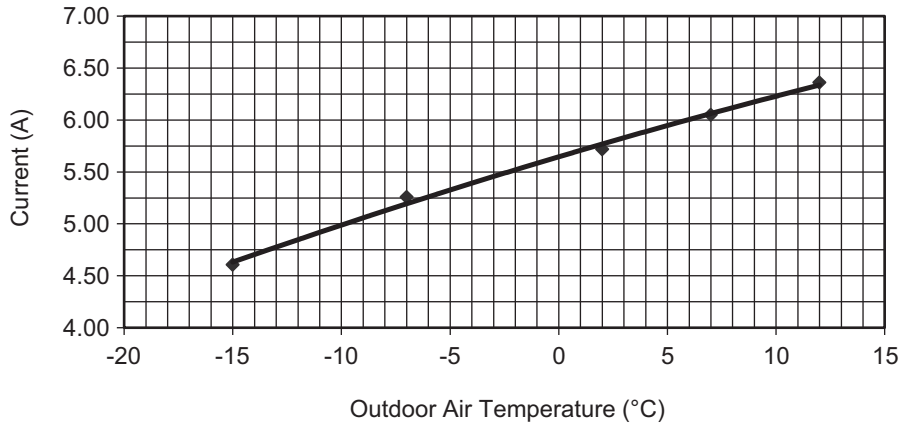
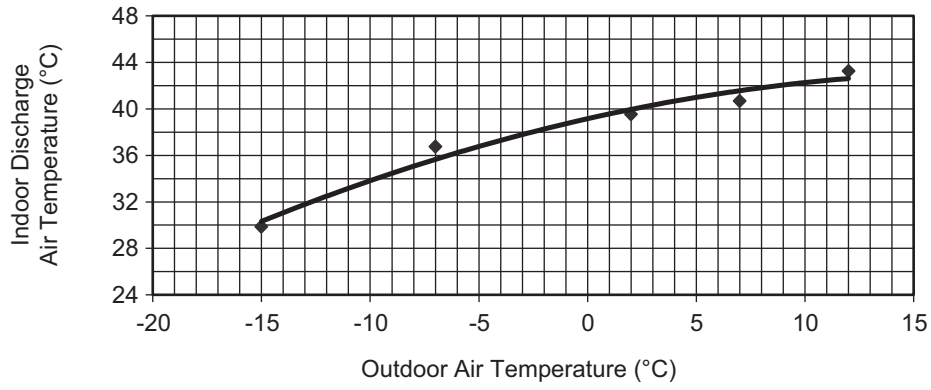

19.3 Piping Length Correction Factor

The characteristic of the unit has to be corrected in accordance with the piping length.

19.3.1 CS-TE20TKEW CU-TE20TKE CS-TE25TKEW CU-TE25TKE CS-TE35TKEW CU-TE35TKE CS-TE42TKEW CU-TE42TKE

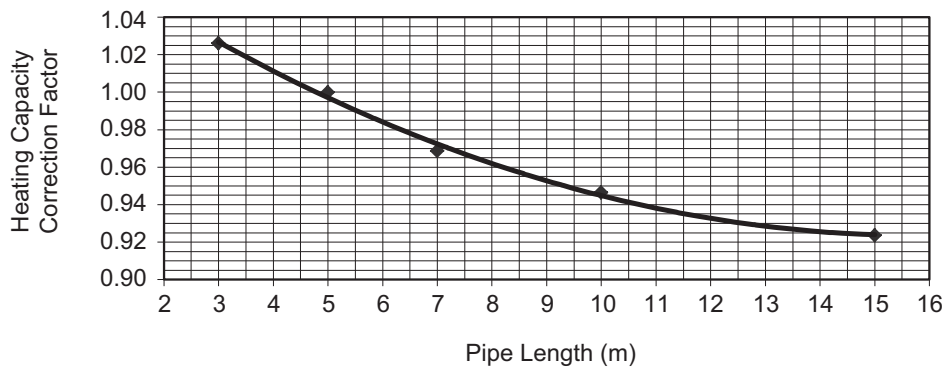
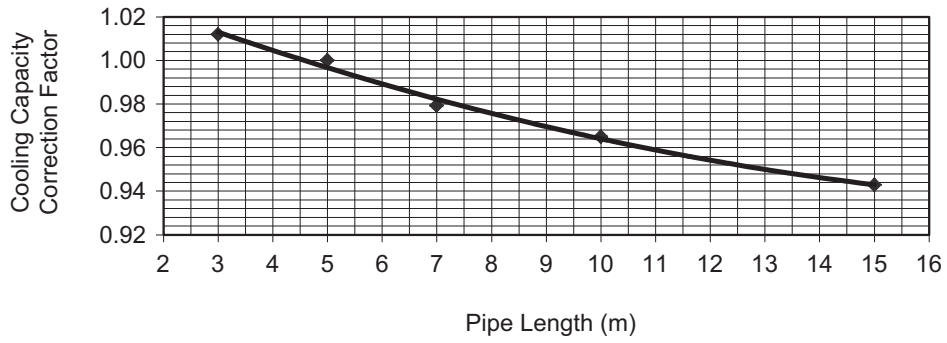

Note: The graphs show the factor after added right amount of additional refrigerant.

20. Exploded View and Replacement Parts List

20.1 Indoor Unit

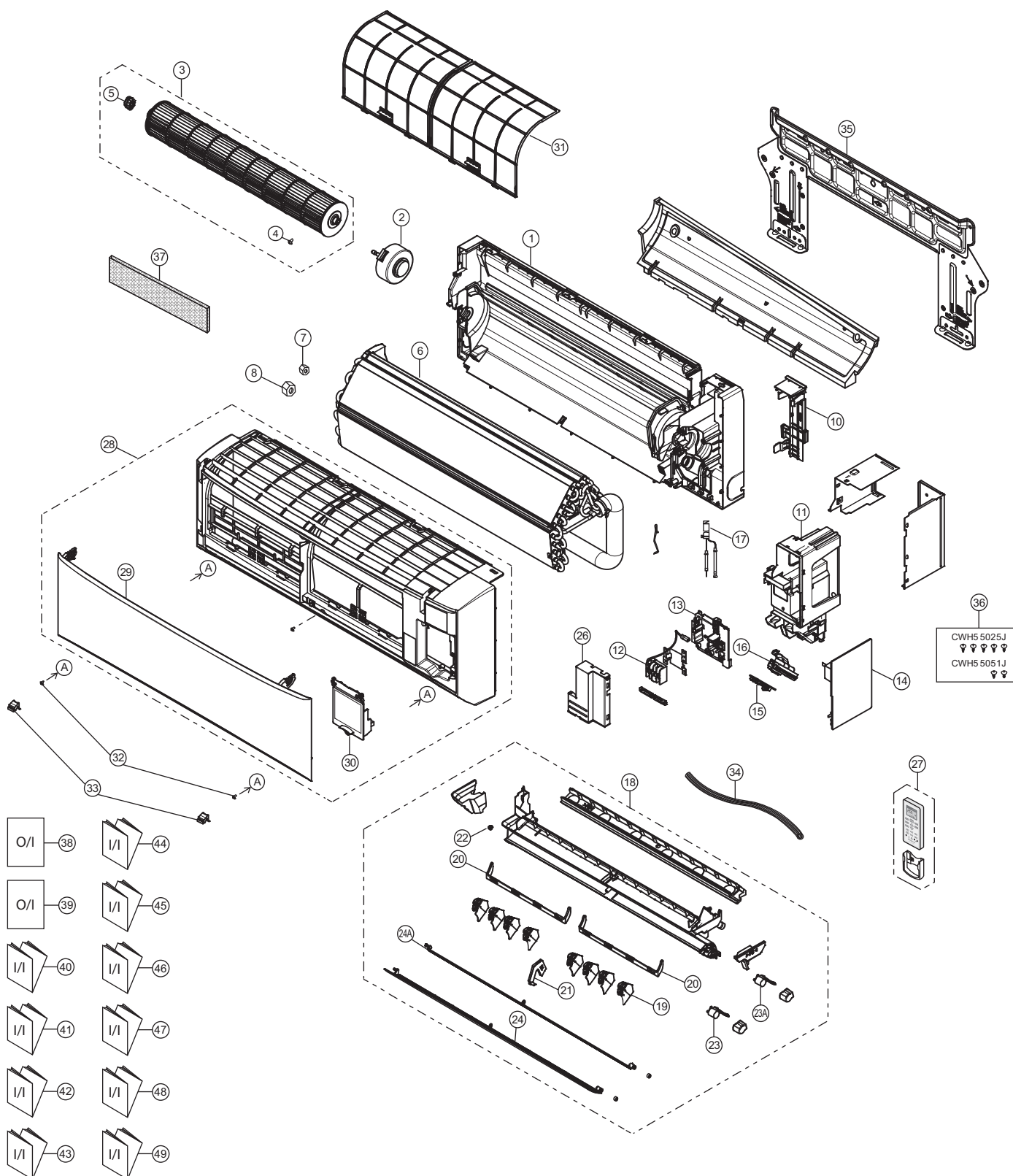

Note

The above exploded view is for the purpose of parts disassembly and replacement. The non-numbered parts are not kept as standard service parts.

SAFETY	REF. NO.	PART NAME & DESCRIPTION	QTY.	CS-TE20TKEW	CS-TE25TKEW	CS-TE35TKEW	REMARK
	1	CHASSIS COMPLETE	1	ACXD50C00440	←	←	
⚠	2	FAN MOTOR	1	L6CBYYL0195	←	←	O
	3	CROSS-FLOW FAN COMPLETE	1	CWH02C1159	←	←	
	4	SCREW - CROSS-FLOW FAN	1	CWH551146	←	←	
	5	BEARING ASSY	1	CWH64K1010	←	←	
	6	EVAPORATOR	1	ACXB30C02730	←	←	
	7	FLARE NUT (LIQUID)	1	CWT251030	←	←	
	8	FLARE NUT (GAS)	1	CWT251031	←	←	
	10	BACK COVER CHASSIS	1	CWD933857A	←	←	
	11	CONTROL BOARD CASING	1	ACXH10-00870	←	←	
⚠	12	TERMINAL BOARD COMPLETE	1	ACXA28C00260	←	←	O
	13	PARTICULAR PIECE - TERMINAL	1	ACXD93-02450	←	←	
⚠	14	ELECTRONIC CONTROLLER - MAIN	1	ACXA73C12140	ACXA73C12150	ACXA73C12160	O
⚠	15	ELECTRONIC CONTROLLER - INDICATOR	1	ACXA73-06360	←	←	O
	16	INDICATOR HOLDER	1	ACXD93-02460	←	←	
	17	SENSOR COMPLETE	1	CWA50C2664	←	←	O
	18	DISCHARGE GRILLE COMPLETE	1	ACXE20C00850	←	←	
	19	VERTICAL VANE	8	ACXE24-00590	←	←	
	20	CONNECTING BAR	2	ACXE26-00250	←	←	
	21	FULCRUM	1	ACXH62-00120	←	←	
	22	CAP - DRAIN TRAY	1	CWH521259	←	←	
⚠	23	AIR SWING MOTOR	1	CWA981264	←	←	O
⚠	23A	AIR SWING MOTOR	1	CWA981299	←	←	
	24	HORIZONTAL VANE COMPLETE	1	ACXE24C00940	←	←	
	24A	HORIZONTAL VANE COMPLETE	1	ACXE24C00950	←	←	
	26	CONTROL BOARD COVER - COMPLETE	1	ACXH13C00180	←	←	
	27	REMOTE CONTROL COMPLETE	1	ACXA75C00450	←	←	O
	28	FRONT GRILLE COMPLETE	1	ACXE10C02660	←	←	O
	29	INTAKE GRILLE COMPLETE	1	ACXE22C00760	←	←	
	30	GRILLE DOOR COMPLETE	1	CWE14C1112	←	←	
	31	AIR FILTER	2	CWD001385	←	←	O
	32	SCREW - FRONT GRILLE	3	XTT4+16CFJ	←	←	
	33	CAP - FRONT GRILLE	2	ACXH52-00140	←	←	
	34	DRAIN HOSE	1	CWH851173	←	←	
	35	INSTALLATION PLATE	1	CWH361147	←	←	
	36	BAG COMPLETE - INSTALLATION SCREW	1	CWH82C1705	←	←	
	37	AIR PURIFYING FILTER	1	CWD00C1293	←	←	
	38	OPERATING INSTRUCTION	1	ACXF55-04100	←	←	
	39	OPERATING INSTRUCTION	1	ACXF55-04110	←	←	
	40	INSTALLATION INSTRUCTION	1	ACXF60-05670	←	←	
	41	INSTALLATION INSTRUCTION	1	ACXF60-05680	←	←	
	42	INSTALLATION INSTRUCTION	1	ACXF60-05690	←	←	
	43	INSTALLATION INSTRUCTION	1	ACXF60-05700	←	←	
	44	INSTALLATION INSTRUCTION	1	ACXF60-05710	←	←	
	45	INSTALLATION INSTRUCTION	1	ACXF60-05720	←	←	
	46	INSTALLATION INSTRUCTION	1	ACXF60-05730	←	←	
	47	INSTALLATION INSTRUCTION	1	ACXF60-05770	←	←	

SAFETY	REF. NO.	PART NAME & DESCRIPTION	QTY.	CS-TE20TKEW	CS-TE25TKEW	CS-TE35TKEW	REMARK
	48	INSTALLATION INSTRUCTION	1	ACXF60-05750	←	←	
	49	INSTALLATION INSTRUCTION	1	ACXF60-05760	←	←	

(NOTE)

- All parts are supplied from PAPAMY, Malaysia (Vendor Code: 00029488).
- “O” marked parts are recommended to be kept in stock.

SAFETY	REF. NO.	PART NAME & DESCRIPTION	QTY.	CS-TE42TKEW	REMARK
	1	CHASSIS COMPLETE	1	ACXD50C00440	
⚠	2	FAN MOTOR	1	L6CBYYYYL0195	O
	3	CROSS-FLOW FAN COMPLETE	1	CWH02C1159	
	4	SCREW - CROSS-FLOW FAN	1	CWH551146	
	5	BEARING ASSY	1	CWH64K1010	
	6	EVAPORATOR	1	ACXB30C02740	
	7	FLARE NUT (LIQUID)	1	CWT251030	
	8	FLARE NUT (GAS)	1	CWT251032	
	10	BACK COVER CHASSIS	1	CWD933857A	
	11	CONTROL BOARD CASING	1	ACXH10-00870	
⚠	12	TERMINAL BOARD COMPLETE	1	ACXA28C00260	O
	13	PARTICULAR PIECE - TERMINAL	1	ACXD93-02450	
⚠	14	ELECTRONIC CONTROLLER - MAIN	1	ACXA73C12170	O
⚠	15	ELECTRONIC CONTROLLER - INDICATOR	1	ACXA73-06360	O
	16	INDICATOR HOLDER	1	ACXD93-02460	
	17	SENSOR COMPLETE	1	CWA50C2664	O
	18	DISCHARGE GRILLE COMPLETE	1	ACXE20C00850	
	19	VERTICAL VANE	8	ACXE24-00590	
	20	CONNECTING BAR	2	ACXE26-00250	
	21	FULCRUM	1	ACXH62-00120	
	22	CAP - DRAIN TRAY	1	CWH521259	
⚠	23	AIR SWING MOTOR	1	CWA981264	O
⚠	23A	AIR SWING MOTOR	1	CWA981299	
	24	HORIZONTAL VANE COMPLETE	1	ACXE24C00940	
	24A	HORIZONTAL VANE COMPLETE	1	ACXE24C00950	
	26	CONTROL BOARD COVER - COMPLETE	1	ACXH13C00180	
	27	REMOTE CONTROL COMPLETE	1	ACXA75C00450	O
	28	FRONT GRILLE COMPLETE	1	ACXE10C02660	O
	29	INTAKE GRILLE COMPLETE	1	ACXE22C00760	
	30	GRILLE DOOR COMPLETE	1	CWE14C1112	
	31	AIR FILTER	2	CWD001385	O
	32	SCREW - FRONT GRILLE	3	XTT4+16CFJ	
	33	CAP - FRONT GRILLE	2	ACXH52-00140	
	34	DRAIN HOSE	1	CWH851173	
	35	INSTALLATION PLATE	1	CWH361147	
	36	BAG COMPLETE - INSTALLATION SCREW	1	CWH82C1705	
	37	AIR PURIFYING FILTER	1	CWD00C1293	
	38	OPERATING INSTRUCTION	1	ACXF55-04100	
	39	OPERATING INSTRUCTION	1	ACXF55-04110	
	40	INSTALLATION INSTRUCTION	1	ACXF60-05670	
	41	INSTALLATION INSTRUCTION	1	ACXF60-05680	
	42	INSTALLATION INSTRUCTION	1	ACXF60-05690	
	43	INSTALLATION INSTRUCTION	1	ACXF60-05700	
	44	INSTALLATION INSTRUCTION	1	ACXF60-05710	
	45	INSTALLATION INSTRUCTION	1	ACXF60-05720	
	46	INSTALLATION INSTRUCTION	1	ACXF60-05730	
	47	INSTALLATION INSTRUCTION	1	ACXF60-05770	
	48	INSTALLATION INSTRUCTION	1	ACXF60-05750	
	49	INSTALLATION INSTRUCTION	1	ACXF60-05760	

(NOTE)

- All parts are supplied from PAPAMY, Malaysia (Vendor Code: 00029488).
- "O" marked parts are recommended to be kept in stock.

20.2 Outdoor Unit

20.2.1 CU-TE20TKE CU-TE25TKE CU-TE35TKE

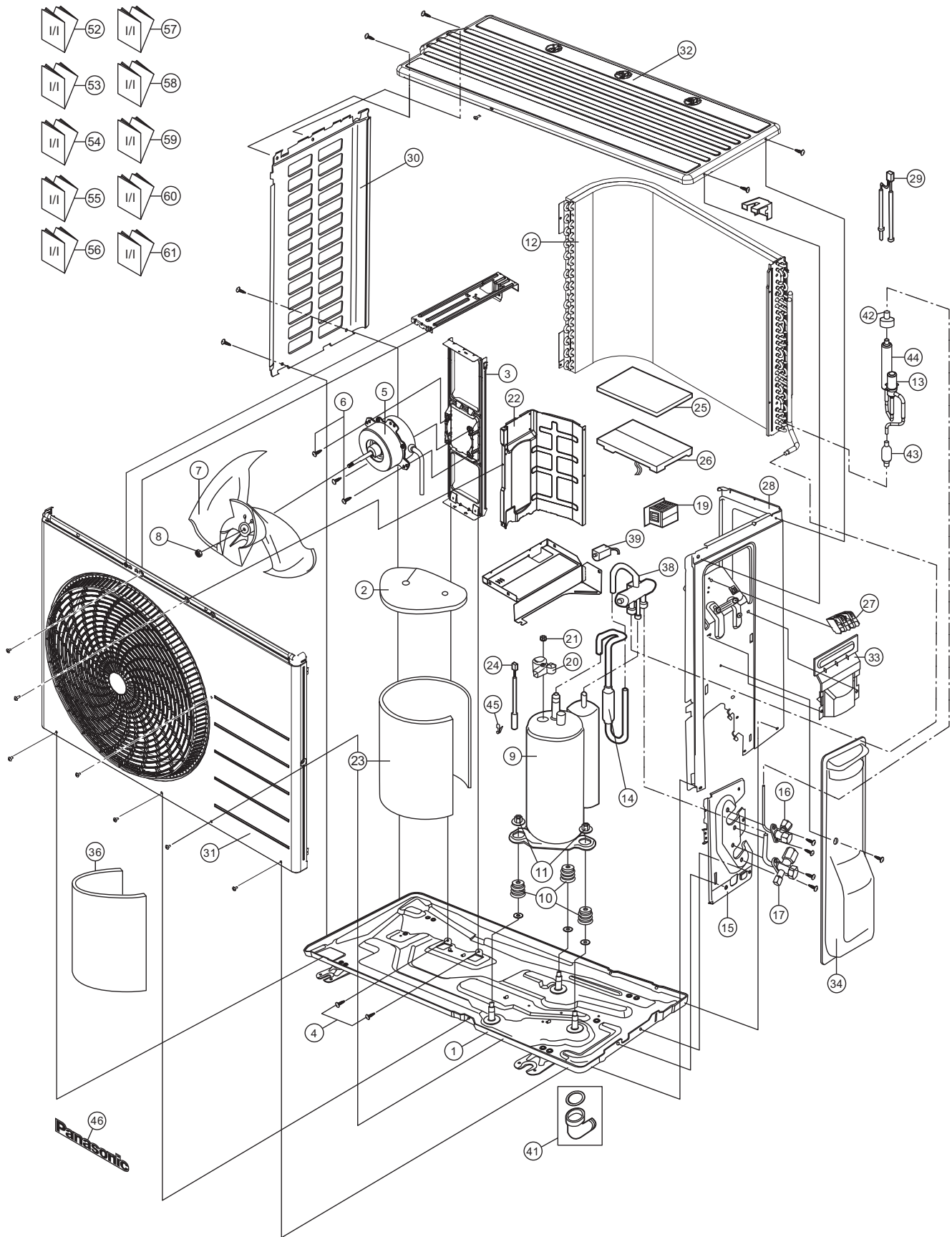

Note
The above exploded view is for the purpose of parts disassembly and replacement.
The non-numbered parts are not kept as standard service parts.

SAFETY	REF. NO.	PART NAME & DESCRIPTION	QTY.	CU-TE20TKE	CU-TE25TKE	CU-TE35TKE	REMARK
	1	CHASSIS COMPLETE	1	ACXD52K00150	←	CWD52K1399	
	2	SOUND PROOF MATERIAL (TOP)	1	CWG302737	←	CWG302314	
	3	FAN MOTOR BRACKET	1	CWD541157	←	←	
	4	SCREW - FAN MOTOR BRACKET	2	CWH551217	←	←	
⚠	5	FAN MOTOR	1	L6CAYYYL0064	←	L6CAYYYL0047	O
	6	SCREW - FAN MOTOR MOUNT	4	CWH55252J	←	←	
	7	PROPELLER FAN ASSY	1	CWH03K1100	←	←	
	8	NUT - PROPELLER FAN	1	CWH56053J	←	←	
⚠	9	COMPRESSOR	1	5SS072XGA21	←	5RS102XNA21	O
	10	ANTI - VIBRATION BUSHING	3	CWH501038	←	CWH50077	
	11	NUT - COMPRESSOR MOUNT	3	CWH561096	←	←	
	12	CONDENSER	1	ACXB32C00770	ACXB32C00780	CWB32C3797	
	13	EXPANSION VALVE	1	CWB051078	←	←	
	14	DISCHARGE MUFFLER (4 W. VALVE)	1	CWB121010	←	←	
	15	HOLDER COUPLING	1	CWH351233	←	←	
	16	2-WAYS VALVE (LIQUID)	1	CWB021180J	←	CWB021589	O
	17	3-WAY VALVE (GAS)	1	CWB011374	←	←	O
⚠	19	REACTOR	1	G0C103J00045	←	G0C103J00013	O
	20	TERMINAL COVER	1	CWH171041	←	CWH171039A	
	21	NUT - TERMINAL COVER	1	-	-	CWH7080300J	
	22	SOUND PROOF BOARD	1	CWH151427	←	←	
	23	SOUND PROOF MATERIAL	1	ACXG30-00530	←	CWG302948	
	24	SENSOR CO - COMP TEMP	1	CWA50C2894	←	CWA50C2205	O
	25	CONTROL BOARD COVER - TOP	1	CWH131264	←	←	
⚠	26	ELECTRONIC CONTROLLER - MAIN	1	ACXA73C22460R	ACXA73C22740R	ACXA73C21030R	O
⚠	27	TERMINAL BOARD ASSY	1	CWA28K1110J	←	←	O
	28	CABINET SIDE PLATE CO.	1	ACXE04C00310	←	←	
	29	SENSOR CO - AIR TEMP AND PIPE TEMP	1	CWA50C3080	←	←	O
	30	CABINET SIDE PLATE	1	ACXE04-00130A	←	←	
	31	CABINET FRONT PLATE CO.	1	CWE06C1566	←	←	
	32	CABINET TOP PLATE	1	CWE031230A	←	←	
	33	PLATE - C. B. COVER TERMINAL	1	CWH131301	←	←	
	34	CONTROL BOARD COVER CO.	1	CWH13C1359	←	←	
	36	SOUND PROOF MATERIAL	1	-	-	CWG302316	
	38	4-WAYS VALVE	1	ACXB00-00130	←	←	O
⚠	39	V-COIL COMPLETE (4-WAY VALVE)	1	ACXA43C00250	←	←	O
	41	BAG - COMPLETE	1	CWG87C900	←	←	
⚠	42	V-COIL COMPLETE (EXP. VALVE)	1	CWA43C2603	←	←	O
	43	STRAINER	1	CWB11094	←	←	
	44	DISCHARGE MUFFLER	1	CWB121021	←	←	
	45	PLATE SPRING	1	CWH71044	←	-	
	46	PANASONIC BADGE	1	CWE373439	←	←	
	52	INSTALLATION INSTRUCTION	1	ACXF60-07370	←	←	
	53	INSTALLATION INSTRUCTION	1	ACXF60-07380	←	←	
	54	INSTALLATION INSTRUCTION	1	ACXF60-07390	←	←	
	55	INSTALLATION INSTRUCTION	1	ACXF60-07400	←	←	
	56	INSTALLATION INSTRUCTION	1	ACXF60-07410	←	←	

SAFETY	REF. NO.	PART NAME & DESCRIPTION	QTY.	CU-TE20TKE	CU-TE25TKE	CU-TE35TKE	REMARK
	57	INSTALLATION INSTRUCTION	1	ACXF60-07420	←	←	
	58	INSTALLATION INSTRUCTION	1	ACXF60-07430	←	←	
	59	INSTALLATION INSTRUCTION	1	ACXF60-07440	←	←	
	60	INSTALLATION INSTRUCTION	1	ACXF60-07450	←	←	
	61	INSTALLATION INSTRUCTION	1	ACXF60-07460	←	←	

(NOTE)

- All parts are supplied from PAPAMY, Malaysia (Vendor Code: 00029488).
- “O” marked parts are recommended to be kept in stock.

20.2.2 CU-TE42TKE

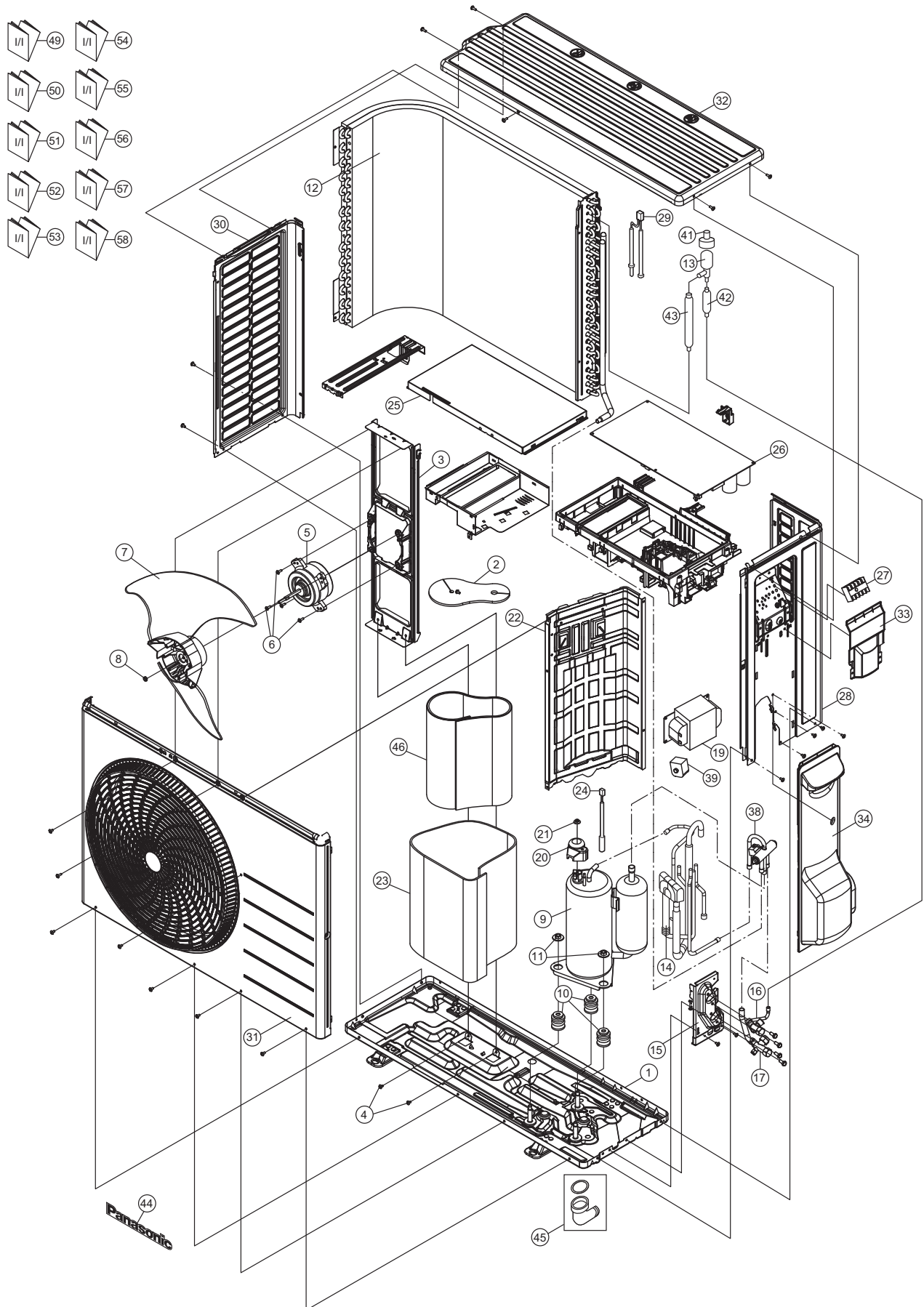

Note
 The above exploded view is for the purpose of parts disassembly and replacement.
 The non-numbered parts are not kept as standard service parts.

SAFETY	REF. NO.	PART NAME & DESCRIPTION	QTY.	CU-TE42TKE	REMARK
	1	CHASSIS COMPLETE	1	CWD52K1277	
	2	SOUND PROOF MATERIAL	1	CWG302719	
	3	FAN MOTOR BRACKET	1	CWD541167	
	4	SCREW - FAN MOTOR BRACKET	2	CWH551217	
⚠	5	FAN MOTOR	1	ARS6411AC	O
	6	SCREW - FAN MOTOR MOUNT	4	CWH55252J	
	7	PROPELLER FAN ASSY	1	CWH03K1066	
	8	NUT - PROPELLER FAN	1	CWH56053J	
⚠	9	COMPRESSOR	1	5RS102XNA21	O
	10	ANTI - VIBRATION BUSHING	3	CWH50077	
	11	NUT - COMPRESSOR MOUNT	3	CWH561096	
	12	CONDENSER	1	CWB32C3681	
	13	EXPANSION VALVE	1	CWB051078	
	14	DISCHARGE MUFFLER (4 W. VALVE)	1	CWB121010	
	15	HOLDER COUPLING	1	CWH351233	
	16	2-WAYS VALVE (LIQUID)	1	CWB021589	O
	17	3-WAY VALVE (GAS)	1	CWB011367	O
⚠	19	REACTOR	1	G0C103J00013	O
	20	TERMINAL COVER	1	CWH171039A	
	21	NUT - TERMINAL COVER	1	CWH7080300J	
	22	SOUND PROOF BOARD	1	CWH151274	
	23	SOUND PROOF MATERIAL (BODY)	1	CWG302949	
	24	SENSOR CO - COMP TEMP	1	CWA50C2894	O
	25	CONTROL BOARD COVER - TOP	1	CWH131473	
⚠	26	ELECTRONIC CONTROLLER - MAIN	1	ACXA73C21040R	O
⚠	27	TERMINAL BOARD ASSY	1	CWA28K1110J	O
	28	CABINET SIDE PLATE CO.	1	CWE04C1493	
	29	SENSOR CO - AIR TEMP AND PIPE TEMP	1	CWA50C3079	O
	30	CABINET SIDE PLATE	1	CWE041617A	
	31	CABINET FRONT PLATE CO.	1	CWE06C1360	
	32	CABINET TOP PLATE	1	CWE031148A	
	33	PLATE - C. B. COVER TERMINAL	1	CWH131470	
	34	CONTROL BOARD COVER CO.	1	CWH13C1253	
	38	4-WAYS VALVE	1	ACXB00-00130	O
⚠	39	V-COIL COMPLETE (4-WAY VALVE)	1	ACXA43C00250	O
⚠	41	V-COIL COMPLETE	1	CWA43C2603	O
	42	DISCHARGE MUFFLER	1	CWB121021	
	43	STRAINER	1	CWB11094	
	44	PANASONIC BADGE	1	CWE373439	
	45	BAG - COMPLETE	1	CWG87C900	
	46	SOUND PROOF MATERIAL	1	CWG302701	
	49	INSTALLATION INSTRUCTION	1	ACXF60-07370	
	50	INSTALLATION INSTRUCTION	1	ACXF60-07380	
	51	INSTALLATION INSTRUCTION	1	ACXF60-07390	
	52	INSTALLATION INSTRUCTION	1	ACXF60-07400	

SAFETY	REF. NO.	PART NAME & DESCRIPTION	QTY.	CU-TE42TKE	REMARK
	53	INSTALLATION INSTRUCTION	1	ACXF60-07410	
	54	INSTALLATION INSTRUCTION	1	ACXF60-07420	
	55	INSTALLATION INSTRUCTION	1	ACXF60-07430	
	56	INSTALLATION INSTRUCTION	1	ACXF60-07440	
	57	INSTALLATION INSTRUCTION	1	ACXF60-07450	
	58	INSTALLATION INSTRUCTION	1	ACXF60-07460	

(NOTE)

- All parts are supplied from PAPAMY, Malaysia (Vendor Code: 00029488).
- “O” marked parts are recommended to be kept in stock.