

# Service Manual

## Air Conditioner



**Indoor Unit**  
 CS-E9GFEW  
 CS-E12GFEW  
 CS-E18GFEW  
 CS-E9GFEW-2  
 CS-E12GFEW-2

**Outdoor Unit**  
 CU-E9PFE  
 CU-E12PFE  
 CU-E18PFE  
 CU-E9PFE  
 CU-E12PFE

**Destination**  
 Europe

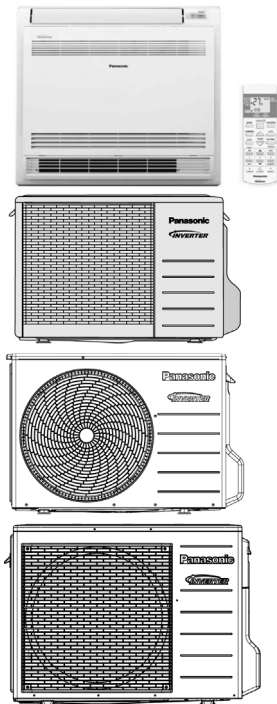

Please file and use this manual together with the Service Manual for Model No. CS-E9GFEW, CS-E12GFEW, CS-E18GFEW, CS-E9GFEW-2, CS-E12GFEW-2, Order No. RAC0704001C2, MAC0802015C2, MAC0804027A2.

### WARNING

This service information is designed for experienced repair technicians only and is not designed for use by the general public. It does not contain warnings or cautions to advise non-technical individuals of potential dangers in attempting to service a product. Products powered by electricity should be serviced or repaired only by experienced professional technicians. Any attempt to service or repair the products dealt with in this service information by anyone else could result in serious injury or death.

### IMPORTANT SAFETY NOTICE

There are special components used in this equipment which are important for safety. These parts are marked by  in the Schematic Diagrams, Circuit Board Diagrams, Exploded Views and Replacement Parts List. It is essential that these critical parts should be replaced with manufacturer's specified parts to prevent shock, fire or other hazards. Do not modify the original design without permission of manufacturer.

### PRECAUTION OF LOW TEMPERATURE

In order to avoid frostbite, be assured of no refrigerant leakage during the installation or repairing of refrigerant circuit.



# Panasonic®

# TABLE OF CONTENTS

<b>1. Safety Precautions .....</b>	<b>3</b>
<b>2. Specifications .....</b>	<b>5</b>
<b>3. Location of Controls and Components.....</b>	<b>14</b>
3.1 Indoor Unit.....	14
3.2 Outdoor Unit .....	14
3.3 Remote Control .....	14
<b>4. Dimensions .....</b>	<b>15</b>
4.1 Outdoor Unit .....	15
<b>5. Refrigeration Cycle Diagram .....</b>	<b>17</b>
5.1 CU-E9PFE CU-E12PFE.....	17
5.2 CU-E18PFE.....	18
<b>6. Block Diagram .....</b>	<b>19</b>
6.1 CU-E9PFE CU-E12PFE.....	19
6.2 CU-E18PFE.....	20
<b>7. Wiring Connection Diagram .....</b>	<b>21</b>
7.1 Outdoor Unit .....	21
<b>8. Electronic Circuit Diagram .....</b>	<b>23</b>
8.1 Outdoor Unit .....	23
<b>9. Printed Circuit Board .....</b>	<b>25</b>
9.1 Outdoor Unit .....	25
<b>10. Installation Instruction .....</b>	<b>28</b>
10.1 Indoor Unit.....	28
10.2 Outdoor Unit .....	36
<b>11. Protection Control.....</b>	<b>40</b>
11.1 Protection Control For All Operations.....	40
11.2 Protection Control For Cooling & Soft Dry Operation.....	42
11.3 Protection Control For Heating Operation.....	43
<b>12. Disassembly and Assembly Instructions .....</b>	<b>44</b>
12.1 Outdoor Electronic Controller Removal Procedure .....	44
<b>13. Technical Data .....</b>	<b>47</b>
13.1 Operation Characteristics.....	47
13.2 Sensible Capacity Chart.....	59
<b>14. Exploded View and Replacement Parts     List .....</b>	<b>60</b>
14.1 Outdoor Unit .....	60

# 1. Safety Precautions







- Read the following “SAFETY PRECAUTIONS” carefully before perform any servicing.
- Electrical work must be installed or serviced by a licensed electrician. Be sure to use the correct rating of the power plug and main circuit for the model installed.
- The caution items stated here must be followed because these important contents are related to safety. The meaning of each indication used is as below. Incorrect installation or servicing due to ignoring of the instruction will cause harm or damage, and the seriousness is classified by the following indications.

 <b>WARNING</b>	This indication shows the possibility of causing death or serious injury.
 <b>CAUTION</b>	This indication shows the possibility of causing injury or damage to properties.

- The items to be followed are classified by the symbols:

	This symbol denotes item that is PROHIBITED from doing.
---	---







- Carry out test run to confirm that no abnormality occurs after the servicing. Then, explain to user the operation, care and maintenance as stated in instructions. Please remind the customer to keep the operating instructions for future reference.

 <b>WARNING</b>	
1.	Do not modify the machine, part, material during repairing service.
2.	If wiring unit is supplied as repairing part, do not repair or connect the wire even only partial wire break. Exchange the whole wiring unit.
3.	Do not wrench the fasten terminal. Pull it out or insert it straightly.
4.	Engage dealer or specialist for installation and servicing. If installation of servicing done by the user is defective, it will cause water leakage, electrical shock or fire.
5.	Install according to this installation instructions strictly. If installation is defective, it will cause water leakage, electric shock or fire.
6.	Use the attached accessories parts and specified parts for installation and servicing. Otherwise, it will cause the set to fall, water leakage, fire or electrical shock.
7.	Install at a strong and firm location which is able to withstand the set's weight. If the strength is not enough or installation is not properly done, the set will drop and cause injury.
8.	For electrical work, follow the local national wiring standard, regulation and the installation instruction. An independent circuit and single outlet must be used. If electrical circuit capacity is not enough or defect found in electrical work, it will cause electrical shock or fire.
9.	This equipment is strongly recommended to install with Earth Leakage Circuit Breaker (ELCB) or Residual Current Device (RCD). Otherwise, it may cause electrical shock and fire in case equipment breakdown or insulation breakdown.
10.	Do not use joint cable for indoor / outdoor connection cable. Use the specified Indoor/Outdoor connection cable, refer to installation instruction <b>CONNECT THE CABLE TO THE INDOOR UNIT</b> and connect tightly for indoor / outdoor connection. Clamp the cable so that no external force will be acted on the terminal. If connecting or fixing is not perfect, it will cause heat up or fire at the connection.
11.	Wire routing must be properly arranged so that control board cover is fixed properly. If control board cover is not fixed perfectly, it will cause heat-up or fire at the connection point of terminal, fire or electrical shock.
12.	When install or relocate air conditioner, do not let any substance other than the specified refrigerant, eg. air etc. mix into refrigeration cycle (piping). (Mixing of air etc. will cause abnormal high pressure in refrigeration cycle and result in explosion, injury etc.).
13.	Do not install outdoor unit near handrail of veranda. When installing air-conditioner unit at veranda of high rise building, child may climb up to outdoor unit and cross over the handrail and causing accident.
14.	This equipment must be properly earthed. Earth line must not be connected to gas pipe, water pipe, earth of lightning rod and telephone. Otherwise, it may cause electric shock in case equipment breakdown or insulation breakdown. 
15.	Keep away from small children, the thin film may cling to nose and mouth and prevent breathing. 
16.	Do not use unspecified cord, modified cord, joint cord or extension cord for power supply cord. Do not share the single outlet with other electrical appliances. Poor contact, poor insulation or over current will cause electrical shock or fire. 
17.	Tighten the flare nut with torque wrench according to specified method. If the flare nut is over-tightened, after a long period, the flare may break and cause refrigerant gas leakage. 
18.	For R410A model, use piping, flare nut and tools which is specified for R410A refrigerant. Using of existing (R22) piping, flare nut and tools may cause abnormally high pressure in the refrigerant cycle (piping), and possibly result in explosion and injury. Thickness or copper pipes used with R410A must be more than 0.8 mm. Never use copper pipes thinner than 0.8 mm. It is desirable that the amount of residual oil less than 40 mg/10 m. 
19.	During installation, install the refrigerant piping properly before run the compressor. (Operation of compressor without fixing refrigeration piping and valves at opened condition will caused suck-in of air, abnormal high pressure in refrigeration cycle and result in explosion, injury etc).

 **WARNING**

20.	During pump down operation, stop the compressor before remove the refrigeration piping. (Removal of compressor while compressor is operating and valves are opened will cause suck-in of air, abnormal high pressure in refrigeration cycle and result in explosion, injury etc.)	
21.	After completion of installation or service, confirm there is no leakage or refrigerant gas. It may generate toxic gas when the refrigerant contacts with fire.	
22.	Ventilate if there is refrigerant gas leakage during operation. It may cause toxic gas when refrigerant contacts with fire.	
23.	Do not insert your fingers or other objects into the unit, high speed rotating fan may cause injury.	
24.	Must not use other parts except original parts described in catalog and manual.	
25.	Using of refrigerant other than the specified type may cause product damage, burst and injury etc.	

 **CAUTION**

1.	Do not install the unit at place where leakage of flammable gas may occur. In case gas leaks and accumulates at surrounding of the unit, it may cause fire.	
2.	Carry out drainage piping as mentioned in installation instructions. If drainage is not perfect, water may enter the room and damage the furniture.	
3.	Tighten the flare nut with torque wrench according to specified method. If the flare nut is over-tightened, after a long period, the flare may break and cause refrigerant gas leakage.	
4.	Do not touch outdoor unit air inlet and aluminium fin. It may cause injury.	
5.	Select an installation location which is easy for maintenance.	
6.	Pb free solder has a higher melting point than standard solder; typically the melting point is 50°F – 70°F (30°C – 40°C) higher. Please use a high temperature solder iron. In case of the soldering iron with temperature control, please set it to 700 ± 20°F (370 ± 10°C). Pb free solder will tend to splash when heated too high (about 1100°F / 600°C).	
7.	Power supply connection to the room air conditioner. Use power supply cord 3 x 1.5 mm <sup>2</sup> (1.0~1.5HP), 3 x 2.5 mm <sup>2</sup> (2.0HP) type designation 60245 IEC 57 or heavier cord. Connect the power supply cord of the air conditioner to the mains using one of the following method. Power supply point should be in easily accessible place for power disconnection in case of emergency. In some countries, permanent connection of this air conditioner to the power supply is prohibited. 1) Power supply connection to the receptacle using power plug. Use an approved 15/16A (1.0~1.5HP), 16A (2.0HP), power plug with earth pin for the connection to the socket. 2) Power supply connection to a circuit breaker for the permanent connection. Use an approved 16A (1.0~2.0HP) circuit breaker for the permanent connection. It must be a double pole switch with a minimum 3.0 mm contact gap.	
8.	Do not release refrigerant during piping work for installation, servicing, reinstallation and during repairing a refrigerant parts. Take care of the liquid refrigerant, it may cause frostbite.	
9.	Installation or servicing work: It may need two people to carry out the installation or servicing work.	
10.	Do not install this appliance in a laundry room or other location where water may drip from the ceiling, etc.	
11.	Do not sit or step on the unit, you may fall down accidentally.	
12.	Do not touch the sharp aluminium fins or edges of metal parts. If you are required to handle sharp parts during installation or servicing, please wear hand glove. Sharp parts may cause injury.	



## 2. Specifications

Model		Indoor	CS-E9GFEW CS-E9GFEW-2										
		Outdoor	CU-E9PFE										
Performance Test Condition			EUROVENT										
Power Supply		Phase, Hz	Single, 50										
		V	220			230			240				
			Min.	Mid.	Max.	Min.	Mid.	Max.	Min.	Mid.	Max.		
Cooling	Capacity		kW	0.85	2.50	3.00	0.85	2.50	3.00	0.85	2.50	3.00	
			BTU/h	2900	8530	10200	2900	8530	10200	2900	8530	10200	
			kcal/h	730	2150	2580	730	2150	2580	730	2150	2580	
	Running Current		A	–	2.60	–	–	2.50	–	–	2.40	–	
	Input Power		W	245	555	765	245	555	765	245	555	765	
	Annual Consumption		kWh	–	278	–	–	278	–	–	278	–	
	EER		W/W	3.47	4.50	3.92	3.47	4.50	3.92	3.47	4.50	3.92	
			BTU/hW	11.84	15.37	13.33	11.84	15.37	13.33	11.84	15.37	13.33	
			kcal/hW	2.98	3.87	3.37	2.98	3.87	3.37	2.98	3.87	3.37	
	ErP	Pdesign	kW	2.5									
		SEER	(W/W)	6.1									
		Annual Consumption	kWh	143									
		Class		A++									
	Power Factor		%	–	97	–	–	97	–	–	96	–	
	Indoor Noise (H / L / QLo)		dB-A	38 / 27 / 23									
			Power Level dB	54 / – / –									
	Outdoor Noise (H / L / QLo)		dB-A	46 / – / –									
			Power Level dB	61 / – / –									
	Heating	Capacity		kW	0.85	3.40	5.00	0.85	3.40	5.00	0.85	3.40	5.00
				BTU/h	2900	11600	17100	2900	11600	17100	2900	11600	17100
kcal/h				730	2920	4300	730	2920	4300	730	2920	4300	
Running Current		A	–	3.75	–	–	3.60	–	–	3.45	–		
Input Power		W	240	810	1.35k	240	810	1.35k	240	810	1.35k		
COP		W/W	3.54	4.20	3.70	3.54	4.20	3.70	3.54	4.20	3.70		
		BTU/hW	12.08	14.32	12.67	12.08	14.32	12.67	12.08	14.32	12.67		
		kcal/hW	3.04	3.60	3.19	3.04	3.60	3.19	3.04	3.60	3.19		
ErP		Pdesign	kW	2.7									
		Tbivalent	°C	-10									
		SCOP	(W/W)	3.8									
		Annual Consumption	kWh	995									
		Class		A									
Power Factor		%	–	98	–	–	98	–	–	98	–		
Indoor Noise (H / L / QLo)		dB-A	38 / 27 / 23										
		Power Level dB	54 / – / –										
Outdoor Noise (H / L / QLo)		dB-A	47 / – / –										
		Power Level dB	62 / – / –										
Low Temp. : Capacity (kW) / I. Power (W) / COP			3.62 / 1.19k / 3.04										
Extr Low Temp. : Capacity (kW) / I. Power (W) / COP			2.88 / 1.21k / 2.38										
Max Current (A) / Max Input Power (W)			6.20 / 1.35k										
Starting Current (A)			3.75										

Model		Indoor		CS-E9GFEW CS-E9GFEW-2		
		Outdoor		CU-E9PFE		
Compressor	Type	Hermetic Motor (Rotary)				
	Motor Type	Brushless (6 poles)				
	Output Power	W		700		
Indoor Fan	Type	Turbo Fan				
	Material	ASG				
	Motor Type	DC / Transistor (8-poles)				
	Input Power	W		-		
	Output Power	W		48		
	Speed	QLo	Cool	rpm	360	
			Heat	rpm	360	
		Lo	Cool	rpm	410	
			Heat	rpm	410	
		Me	Cool	rpm	510	
			Heat	rpm	520	
		Hi	Cool	rpm	620	
			Heat	rpm	630	
	SHi	Cool	rpm	660		
Heat		rpm	670			
Outdoor Fan	Type	Propeller Fan				
	Material	PP				
	Motor Type	DC (8-poles)				
	Input Power	W		-		
	Output Power	W		40		
	Speed	Hi	Cool	rpm	770	
Heat			rpm	770		
Moisture Removal		L/h (Pt/h)		1.4 (2.9)		
Indoor Airflow	QLo	Cool	m <sup>3</sup> /min (ft <sup>3</sup> /min)	5.4 (191)		
		Heat	m <sup>3</sup> /min (ft <sup>3</sup> /min)	5.5 (194)		
	Lo	Cool	m <sup>3</sup> /min (ft <sup>3</sup> /min)	6.2 (217)		
		Heat	m <sup>3</sup> /min (ft <sup>3</sup> /min)	6.2 (221)		
	Me	Cool	m <sup>3</sup> /min (ft <sup>3</sup> /min)	7.7 (270)		
		Heat	m <sup>3</sup> /min (ft <sup>3</sup> /min)	7.9 (280)		
	Hi	Cool	m <sup>3</sup> /min (ft <sup>3</sup> /min)	9.3 (328)		
		Heat	m <sup>3</sup> /min (ft <sup>3</sup> /min)	9.6 (339)		
SHi	Cool	m <sup>3</sup> /min (ft <sup>3</sup> /min)	9.9 (350)			
	Heat	m <sup>3</sup> /min (ft <sup>3</sup> /min)	10.2 (361)			
Outdoor Airflow	Hi	Cool	m <sup>3</sup> /min (ft <sup>3</sup> /min)	29.8 (1050)		
		Heat	m <sup>3</sup> /min (ft <sup>3</sup> /min)	29.8 (1050)		
Refrigeration Cycle	Control Device			Expansion Valve		
	Refrigerant Oil	cm <sup>3</sup>		FV50S (320)		
	Refrigerant Type	g (oz)		R410A, 970 (34.2)		
Dimension	Height (I/D / O/D)	mm (inch)		600 (23-5/8) / 542 (21-11/32)		
	Width (I/D / O/D)	mm (inch)		700 (27-9/16) / 780 (30-23/32)		
	Depth (I/D / O/D)	mm (inch)		210 (8-9/32) / 289 (11-13/32)		
Weight	Net (I/D / O/D)	kg (lb)		14 (31) / 33 (73)		

Model		Indoor	CS-E9GFEW CS-E9GFEW-2	
		Outdoor	CU-E9PFE	
Piping	Pipe Diameter (Liquid / Gas)	mm (inch)	6.35 (1/4) / 9.52 (3/8)	
	Standard length	m (ft)	5.0 (16.4)	
	Length range (min – max)	m (ft)	3 (9.8) ~ 15 (49.2)	
	I/D & O/D Height different	m (ft)	5.0 (16.4)	
	Additional Gas Amount	g/m (oz/ft)	20 (0.2)	
	Length for Additional Gas	m (ft)	7.5 (24.6)	
Drain Hose	Inner Diameter	mm	15	
	Length	mm	220	
Indoor Heat Exchanger	Fin Material		Aluminium (Pre Coat)	
	Fin Type		Slit Fin	
	Row × Stage × FPI		2 × 22 × 19	
	Size (W × H × L)	mm	510 × 396 × 24	
Outdoor Heat Exchanger	Fin Material		Aluminium	
	Fin Type		Corrugated Fin	
	Row × Stage × FPI		2 × 24 × 17	
	Size (W × H × L)	mm	36.4 × 504 × 713:684	
Air Filter	Material		Polypropelene	
	Type		One-touch	
Power Supply			Outdoor	
Power Supply Cord		A	Nil	
Thermostat			Electronic Contol	
Protection Device			Electronic Contol	
			Dry Bulb	Wet Bulb
Indoor Operation Range	Cooling	Maximum °C	32	23
		Minimum °C	16	11
	Heating	Maximum °C	30	-
		Minimum °C	16	-
Outdoor Operation Range	Cooling	Maximum °C	43	26
		Minimum °C	16	11
	Heating	Maximum °C	24	18
		Minimum °C	-15	-16

- Cooling capacities are based on indoor temperature of 27°C Dry Bulb (80.6°F Dry Bulb), 19.0°C Wet Bulb (66.2°F Wet Bulb) and outdoor air temperature of 35°C DRY BULB (95°F Dry Bulb), 24°C Wet Bulb (75.2°F Wet Bulb)
- Heating capacities are based on indoor temperature of 20°C Dry Bulb (68°F Dry Bulb) and outdoor air temperature of 7°C Dry Bulb (44.6°F Dry Bulb), 6°C Wet Bulb (42.8°F Wet Bulb)
- Heating low temperature capacity, Input Power and COP measured at 230 V, indoor temperature 20°C, outdoor 2/1°C
- Heating extreme low temperature capacity, Input Power and COP measured at 230 V, indoor temperature 20°C, outdoor -7/-8°C
- Standby power consumption ≤0.7W (when switched OFF by remote control, except under self protection control).
- Specifications are subjected to change without prior notice for further improvement.

Model		Indoor	CS-E12GFEW CS-E12GFEW-2									
		Outdoor	CU-E12PFE									
Performance Test Condition			EUROVENT									
Power Supply		Phase, Hz	Single, 50									
		V	220			230			240			
			Min.	Mid.	Max.	Min.	Mid.	Max.	Min.	Mid.	Max.	
Cooling	Capacity		kW	0.85	3.50	3.80	0.85	3.50	3.80	0.85	3.50	3.80
			BTU/h	2900	11900	13000	2900	11900	13000	2900	11900	13000
			kcal/h	730	3010	3270	730	3010	3270	730	3010	3270
	Running Current		A	–	4.35	–	–	4.15	–	–	4.00	–
	Input Power		W	255	940	1.11k	255	940	1.11k	255	940	1.11k
	Annual Consumption		kWh	–	470	–	–	470	–	–	470	–
	EER		W/W	3.33	3.72	3.42	3.33	3.72	3.42	3.33	3.72	3.42
			BTU/hW	11.37	12.66	11.71	11.37	12.66	11.71	11.37	12.66	11.71
			kcal/hW	2.86	3.20	2.95	2.86	3.20	2.95	2.86	3.20	2.95
	ErP	Pdesign	kW	3.5								
		SEER	(W/W)	5.8								
		Annual Consumption	kWh	211								
		Class		A+								
	Power Factor		%	–	98	–	–	98	–	–	98	–
	Indoor Noise (H / L / QLo)		dB-A	39 / 28 / 24								
			Power Level dB	55 / – / –								
	Outdoor Noise (H / L / QLo)		dB-A	48 / – / –								
			Power Level dB	63 / – / –								
Heating	Capacity		kW	0.85	4.00	6.00	0.85	4.00	6.00	0.85	4.00	6.00
			BTU/h	2900	13600	20500	2900	13600	20500	2900	13600	20500
			kcal/h	730	3440	5160	730	3440	5160	730	3440	5160
	Running Current		A	–	4.60	–	–	4.40	–	–	4.20	–
	Input Power		W	245	1.00k	1.90k	245	1.00k	1.90k	245	1.00k	1.90k
	COP		W/W	3.47	4.00	3.16	3.47	4.00	3.16	3.47	4.00	3.16
			BTU/hW	11.84	13.60	10.79	11.84	13.60	10.79	11.84	13.60	10.79
			kcal/hW	2.98	3.44	2.72	2.98	3.44	2.72	2.98	3.44	2.72
	ErP	Pdesign	kW	3.2								
		Tbivalent	°C	-10								
		SCOP	(W/W)	3.8								
		Annual Consumption	kWh	1179								
		Class		A								
	Power Factor		%	–	99	–	–	99	–	–	99	–
	Indoor Noise (H / L / QLo)		dB-A	39 / 27 / 23								
			Power Level dB	55 / – / –								
	Outdoor Noise (H / L / QLo)		dB-A	50 / – / –								
			Power Level dB	65 / – / –								
Low Temp. : Capacity (kW) / I. Power (W) / COP			4.35 / 1.68k / 2.59									
Extr Low Temp. : Capacity (kW) / I. Power (W) / COP			3.37 / 1.49k / 2.26									
Max Current (A) / Max Input Power (W)			8.70 / 1.90k									
Starting Current (A)			4.60									

Model		Indoor		CS-E12GFEW CS-E12GFEW-2		
		Outdoor		CU-E12PFE		
Compressor	Type			Hermetic Motor (Rotary)		
	Motor Type			Brushless (6 poles)		
	Output Power		W	700		
Indoor Fan	Type			Turbo Fan		
	Material			ASG		
	Motor Type			DC / Transistor (8-poles)		
	Input Power		W	-		
	Output Power		W	48		
	Speed	QLo	Cool	rpm	370	
			Heat	rpm	360	
		Lo	Cool	rpm	430	
			Heat	rpm	410	
		Me	Cool	rpm	530	
			Heat	rpm	530	
		Hi	Cool	rpm	640	
			Heat	rpm	650	
	SHi	Cool	rpm	680		
Heat		rpm	690			
Outdoor Fan	Type			Propeller Fan		
	Material			PP		
	Motor Type			DC (8-poles)		
	Input Power		W	-		
	Output Power		W	40		
	Speed	Hi	Cool	rpm	900	
Heat			rpm	910		
Moisture Removal		L/h (Pt/h)	2.0 (4.2)			
Indoor Airflow	QLo	Cool	m <sup>3</sup> /min (ft <sup>3</sup> /min)	5.5 (194)		
		Heat	m <sup>3</sup> /min (ft <sup>3</sup> /min)	5.5 (196)		
	Lo	Cool	m <sup>3</sup> /min (ft <sup>3</sup> /min)	6.4 (225)		
		Heat	m <sup>3</sup> /min (ft <sup>3</sup> /min)	6.3 (223)		
	Me	Cool	m <sup>3</sup> /min (ft <sup>3</sup> /min)	7.9 (278)		
		Heat	m <sup>3</sup> /min (ft <sup>3</sup> /min)	8.2 (288)		
	Hi	Cool	m <sup>3</sup> /min (ft <sup>3</sup> /min)	9.5 (335)		
		Heat	m <sup>3</sup> /min (ft <sup>3</sup> /min)	10.0 (353)		
SHi	Cool	m <sup>3</sup> /min (ft <sup>3</sup> /min)	10.1 (356)			
	Heat	m <sup>3</sup> /min (ft <sup>3</sup> /min)	10.6 (375)			
Outdoor Airflow	Hi	Cool	m <sup>3</sup> /min (ft <sup>3</sup> /min)	33.3 (1175)		
		Heat	m <sup>3</sup> /min (ft <sup>3</sup> /min)	33.3 (1175)		
Refrigeration Cycle	Control Device			Expansion Valve		
	Refrigerant Oil		cm <sup>3</sup>	FV50S (320)		
	Refrigerant Type		g (oz)	R410A, 1.00k (35.3)		
Dimension	Height (I/D / O/D)		mm (inch)	600 (23-5/8) / 619 (24-3/8)		
	Width (I/D / O/D)		mm (inch)	700 (27-9/16) / 824 (32-15/32)		
	Depth (I/D / O/D)		mm (inch)	210 (8-9/32) / 299 (11-25/32)		
Weight	Net (I/D / O/D)		kg (lb)	14 (31) / 34 (75)		

Model		Indoor	CS-E12GFEW CS-E12GFEW-2	
		Outdoor	CU-E12PFE	
Piping	Pipe Diameter (Liquid / Gas)	mm (inch)	6.35 (1/4) / 9.52 (3/8)	
	Standard length	m (ft)	5.0 (16.4)	
	Length range (min – max)	m (ft)	3 (9.8) ~ 15 (49.2)	
	I/D & O/D Height different	m (ft)	5.0 (16.4)	
	Additional Gas Amount	g/m (oz/ft)	20 (0.2)	
	Length for Additional Gas	m (ft)	7.5 (24.6)	
Drain Hose	Inner Diameter	mm	15	
	Length	mm	220	
Indoor Heat Exchanger	Fin Material		Aluminium (Pre Coat)	
	Fin Type		Slit Fin	
	Row × Stage × FPI		2 × 22 × 19	
	Size (W × H × L)	mm	510 × 396 × 24	
Outdoor Heat Exchanger	Fin Material		Aluminium	
	Fin Type		Corrugated Fin	
	Row × Stage × FPI		2 × 28 × 17	
	Size (W × H × L)	mm	36.4 × 588 × 606.6	
Air Filter	Material		Polypropelene	
	Type		One-touch	
Power Supply			Outdoor	
Power Supply Cord		A	Nil	
Thermostat			Electronic Contol	
Protection Device			Electronic Contol	
			Dry Bulb	Wet Bulb
Indoor Operation Range	Cooling	Maximum °C	32	23
		Minimum °C	16	11
	Heating	Maximum °C	30	–
		Minimum °C	16	–
Outdoor Operation Range	Cooling	Maximum °C	43	26
		Minimum °C	16	11
	Heating	Maximum °C	24	18
		Minimum °C	-15	-16

- Cooling capacities are based on indoor temperature of 27°C Dry Bulb (80.6°F Dry Bulb), 19.0°C Wet Bulb (66.2°F Wet Bulb) and outdoor air temperature of 35°C DRY BULB (95°F Dry Bulb), 24°C Wet Bulb (75.2°F Wet Bulb)
- Heating capacities are based on indoor temperature of 20°C Dry Bulb (68°F Dry Bulb) and outdoor air temperature of 7°C Dry Bulb (44.6°F Dry Bulb), 6°C Wet Bulb (42.8°F Wet Bulb)
- Heating low temperature capacity, Input Power and COP measured at 230 V, indoor temperature 20°C, outdoor 2/1°C
- Heating extreme low temperature capacity, Input Power and COP measured at 230 V, indoor temperature 20°C, outdoor -7/-8°C
- Standby power consumption ≤0.7W (when switched OFF by remote control, except under self protection control).
- Specifications are subjected to change without prior notice for further improvement.

Model		Indoor	CS-E18GFEW										
		Outdoor	CU-E18PFE										
Performance Test Condition			EUROVENT										
Power Supply		Phase, Hz	Single, 50										
		V	220			230			240				
			Min.	Mid.	Max.	Min.	Mid.	Max.	Min.	Mid.	Max.		
Cooling	Capacity		kW	0.98	5.00	5.60	0.98	5.00	5.60	0.98	5.00	5.60	
			BTU/h	3340	17100	19100	3340	17100	19100	3340	17100	19100	
			kcal/h	840	4300	4820	840	4300	4820	840	4300	4820	
	Running Current		A	-	7.20	-	-	6.90	-	-	6.70	-	
	Input Power		W	280	1.54k	1.89k	280	1.54k	1.89k	280	1.54k	1.89k	
	Annual Consumption		kWh	-	770	-	-	770	-	-	770	-	
	EER		W/W	3.50	3.25	2.96	3.50	3.25	2.96	3.50	3.25	2.96	
			BTU/hW	11.93	11.10	10.11	11.93	11.10	10.11	11.93	11.10	10.11	
			kcal/hW	3.00	2.79	2.55	3.00	2.79	2.55	3.00	2.79	2.55	
	ErP	Pdesign	kW	5.0									
		SEER	(W/W)	6.2									
		Annual Consumption	kWh	282									
		Class		A++									
	Power Factor		%	-	97	-	-	97	-	-	96	-	
	Indoor Noise (H / L / QLo)		dB-A	44 / 36 / 32									
			Power Level dB	60 / - / -									
	Outdoor Noise (H / L / QLo)		dB-A	47 / - / -									
			Power Level dB	61 / - / -									
	Heating	Capacity		kW	0.98	5.80	7.10	0.98	5.80	7.10	0.98	5.80	7.10
				BTU/h	3340	19800	24200	3340	19800	24200	3340	19800	24200
kcal/h				840	4990	6110	840	4990	6110	840	4990	6110	
Running Current		A	-	7.50	-	-	7.20	-	-	6.90	-		
Input Power		W	340	1.60k	2.30k	340	1.60k	2.30k	340	1.60k	2.30k		
COP		W/W	2.88	3.63	3.09	2.88	3.63	3.09	2.88	3.63	3.09		
		BTU/hW	9.82	12.38	10.52	9.82	12.38	10.52	9.82	12.38	10.52		
		kcal/hW	2.47	3.12	2.66	2.47	3.12	2.66	2.47	3.12	2.66		
ErP		Pdesign	kW	4.4									
		Tbivalent	°C	-10									
		SCOP	(W/W)	3.9									
		Annual Consumption	kWh	1579									
		Class		A									
Power Factor		%	-	97	-	-	97	-	-	97	-		
Indoor Noise (H / L / QLo)		dB-A	46 / 36 / 32										
		Power Level dB	62 / - / -										
Outdoor Noise (H / L / QLo)		dB-A	48 / - / -										
		Power Level dB	62 / - / -										
Low Temp. : Capacity (kW) / I. Power (W) / COP			5.14 / 2.04k / 2.52										
Extr Low Temp. : Capacity (kW) / I. Power (W) / COP			4.44 / 2.10k / 2.11										
Max Current (A) / Max Input Power (W)			10.10 / 2.30k										
Starting Current (A)			7.50										

Model			Indoor	CS-E18GFEW		
			Outdoor	CU-E18PFE		
Compressor	Type			Hermetic Motor (Rotary)		
	Motor Type			Brushless (4 poles)		
	Output Power		W	900		
Indoor Fan	Type			Turbo Fan		
	Material			ASG		
	Motor Type			DC / Transistor (8-poles)		
	Input Power		W	-		
	Output Power		W	48		
	Speed	QLo	Cool	rpm	490	
			Heat	rpm	490	
		Lo	Cool	rpm	570	
			Heat	rpm	610	
		Me	Cool	rpm	660	
			Heat	rpm	740	
		Hi	Cool	rpm	760	
			Heat	rpm	870	
	SHi	Cool	rpm	800		
Heat		rpm	910			
Outdoor Fan	Type			Propeller Fan		
	Material			PP		
	Motor Type			DC (8-poles)		
	Input Power		W	-		
	Output Power		W	40		
	Speed	Hi	Cool	rpm	640	
			Heat	rpm	640	
Moisture Removal			L/h (Pt/h)	2.8 (5.9)		
Indoor Airflow	QLo	Cool	m <sup>3</sup> /min (ft <sup>3</sup> /min)	7.1 (250)		
		Heat	m <sup>3</sup> /min (ft <sup>3</sup> /min)	7.3 (259)		
	Lo	Cool	m <sup>3</sup> /min (ft <sup>3</sup> /min)	8.3 (291)		
		Heat	m <sup>3</sup> /min (ft <sup>3</sup> /min)	9.1 (322)		
	Me	Cool	m <sup>3</sup> /min (ft <sup>3</sup> /min)	9.6 (337)		
		Heat	m <sup>3</sup> /min (ft <sup>3</sup> /min)	11.1 (390)		
	Hi	Cool	m <sup>3</sup> /min (ft <sup>3</sup> /min)	11.0 (388)		
		Heat	m <sup>3</sup> /min (ft <sup>3</sup> /min)	13.0 (459)		
	SHi	Cool	m <sup>3</sup> /min (ft <sup>3</sup> /min)	11.6 (409)		
		Heat	m <sup>3</sup> /min (ft <sup>3</sup> /min)	13.6 (480)		
Outdoor Airflow	Hi	Cool	m <sup>3</sup> /min (ft <sup>3</sup> /min)	39.2 (1385)		
		Heat	m <sup>3</sup> /min (ft <sup>3</sup> /min)	37.9 (1340)		
Refrigeration Cycle	Control Device			Expansion Valve		
	Refrigerant Oil		cm <sup>3</sup>	FV50S (450)		
	Refrigerant Type		g (oz)	R410A, 1.12k (39.5)		
Dimension	Height (I/D / O/D)		mm (inch)	600 (23-5/8) / 695 (27-3/8)		
	Width (I/D / O/D)		mm (inch)	700 (27-9/16) / 875 (34-15/32)		
	Depth (I/D / O/D)		mm (inch)	210 (8-9/32) / 320 (12-5/8)		
Weight	Net (I/D / O/D)		kg (lb)	14 (31) / 46 (101)		



Model		Indoor	CS-E18GFEW	
		Outdoor	CU-E18PFE	
Piping	Pipe Diameter (Liquid / Gas)	mm (inch)	6.35 (1/4) / 12.70 (1/2)	
	Standard length	m (ft)	5.0 (16.4)	
	Length range (min – max)	m (ft)	3 (9.8) ~ 20 (65.6)	
	I/D & O/D Height different	m (ft)	15.0 (49.2)	
	Additional Gas Amount	g/m (oz/ft)	20 (0.2)	
	Length for Additional Gas	m (ft)	7.5 (24.6)	
Drain Hose	Inner Diameter	mm	15	
	Length	mm	220	
Indoor Heat Exchanger	Fin Material		Aluminium (Pre Coat)	
	Fin Type		Slit Fin	
	Row × Stage × FPI		2 × 22 × 19	
	Size (W × H × L)	mm	510 × 396 × 24	
Outdoor Heat Exchanger	Fin Material		Aluminium	
	Fin Type		Corrugated Fin	
	Row × Stage × FPI		2 × 31 × 19	
	Size (W × H × L)	mm	36.4 × 651 × 854.5:824.5	
Air Filter	Material		Polypropelene	
	Type		One-touch	
Power Supply			Outdoor	
Power Supply Cord		A	Nil	
Thermostat			Electronic Contol	
Protection Device			Electronic Contol	
			Dry Bulb	Wet Bulb
Indoor Operation Range	Cooling	Maximum °C	32	23
		Minimum °C	16	11
	Heating	Maximum °C	30	-
		Minimum °C	16	-
Outdoor Operation Range	Cooling	Maximum °C	43	26
		Minimum °C	16	11
	Heating	Maximum °C	24	18
		Minimum °C	-15	-16

- Cooling capacities are based on indoor temperature of 27°C Dry Bulb (80.6°F Dry Bulb), 19.0°C Wet Bulb (66.2°F Wet Bulb) and outdoor air temperature of 35°C DRY BULB (95°F Dry Bulb), 24°C Wet Bulb (75.2°F Wet Bulb)
- Heating capacities are based on indoor temperature of 20°C Dry Bulb (68°F Dry Bulb) and outdoor air temperature of 7°C Dry Bulb (44.6°F Dry Bulb), 6°C Wet Bulb (42.8°F Wet Bulb)
- Heating low temperature capacity, Input Power and COP measured at 230 V, indoor temperature 20°C, outdoor 2/1°C
- Heating extreme low temperature capacity, Input Power and COP measured at 230 V, indoor temperature 20°C, outdoor -7/-8°C
- Standby power consumption ≤0.7W (when switched OFF by remote control, except under self protection control).
- Specifications are subjected to change without prior notice for further improvement.

### 3. Location of Controls and Components

#### 3.1 Indoor Unit

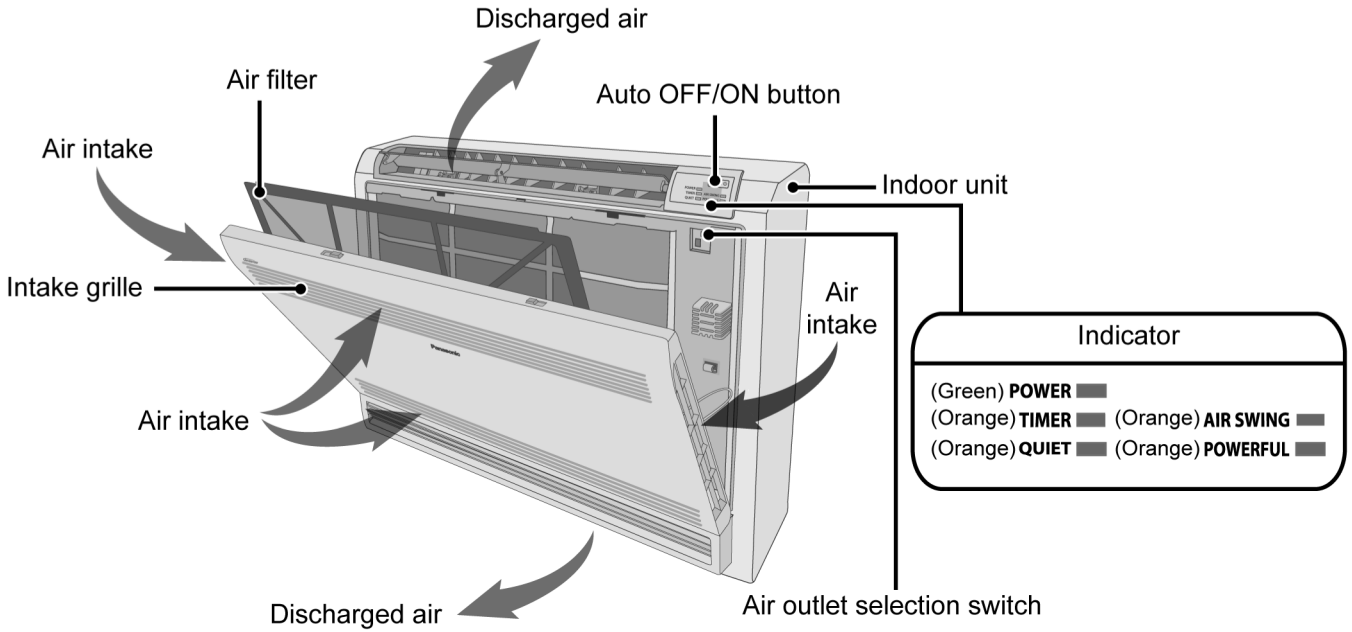

#### 3.2 Outdoor Unit

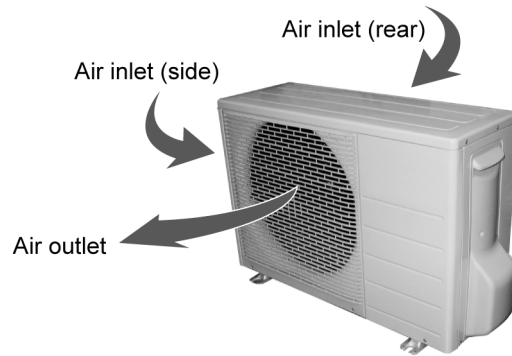

#### 3.3 Remote Control

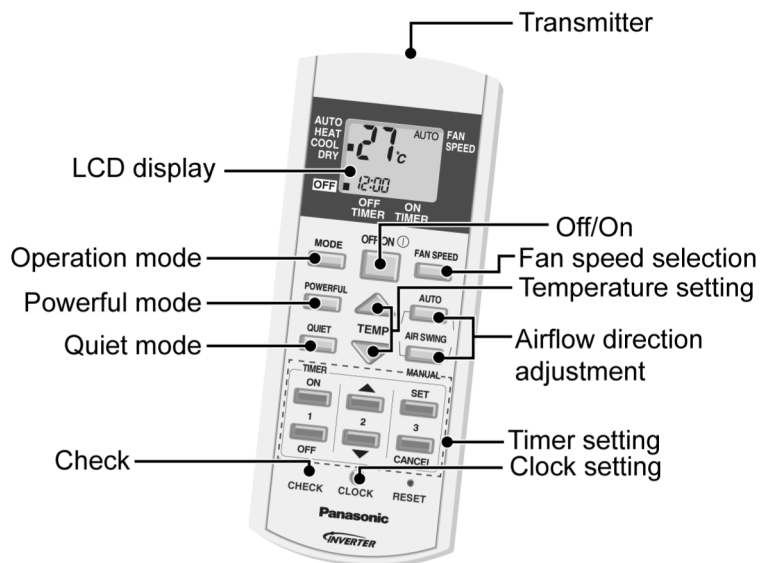

# 4. Dimensions

## 4.1 Outdoor Unit

### 4.1.1 CU-E9PFE

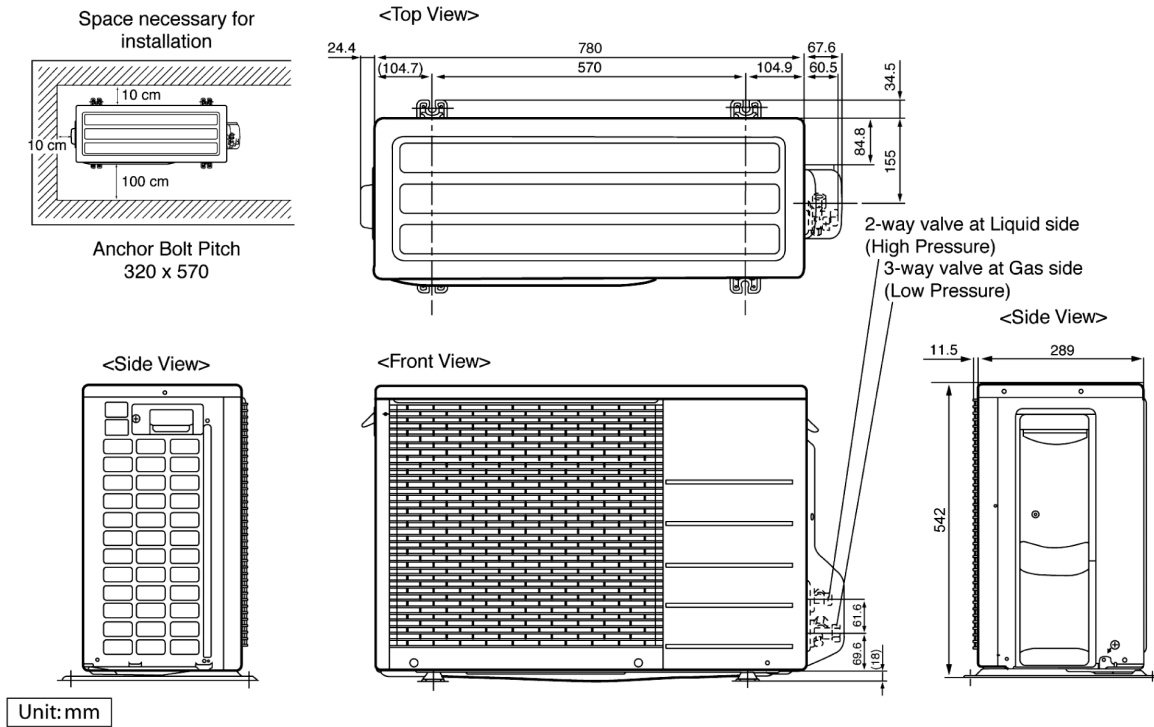

### 4.1.2 CU-E12PFE

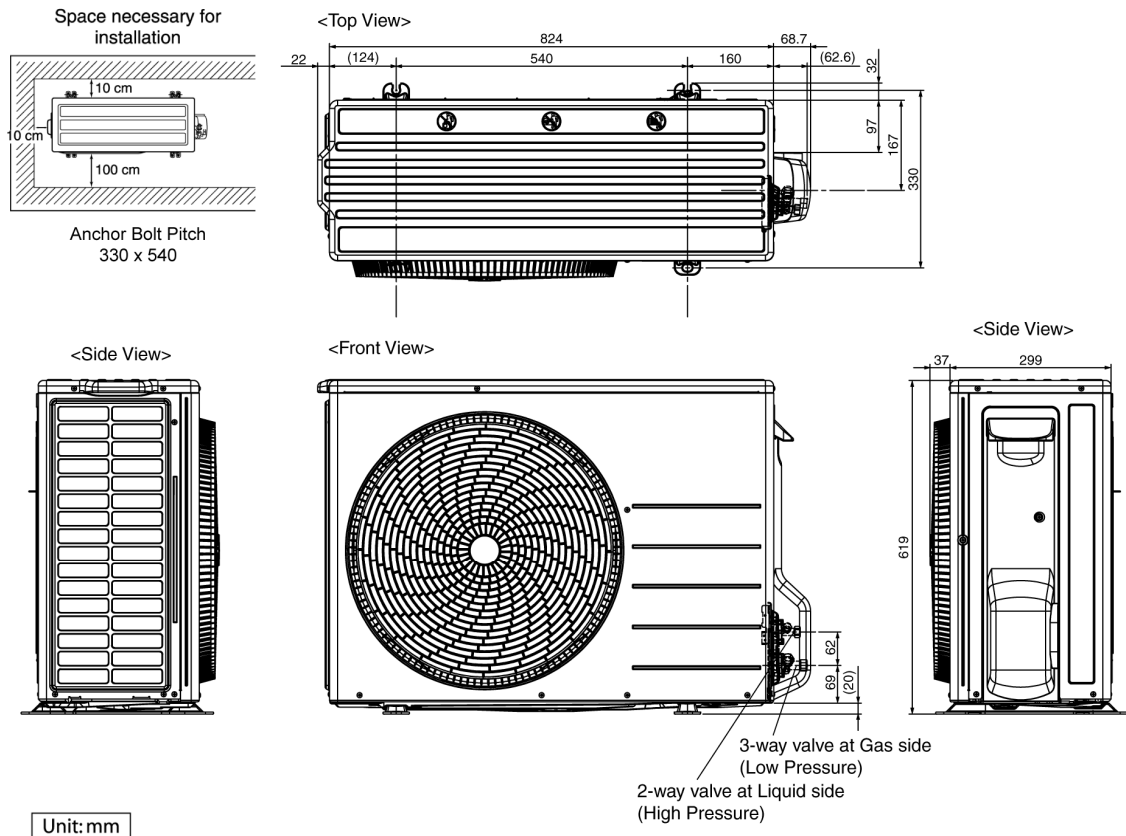

### 4.1.3 CU-E18PFE

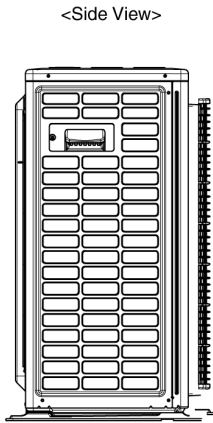
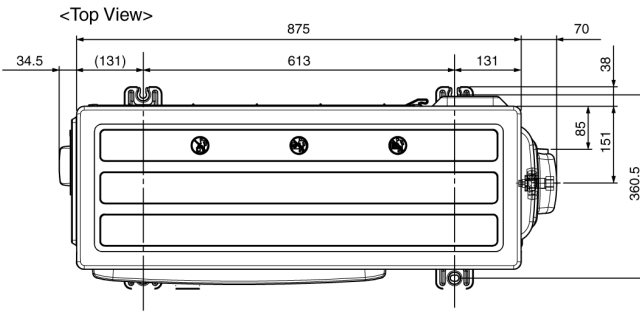
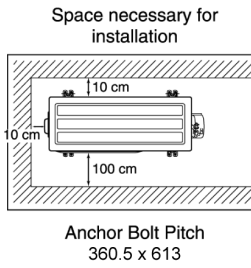

Unit: mm

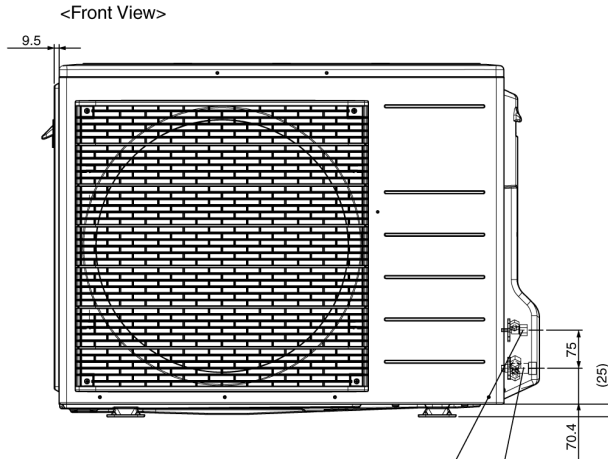

3-way valve at Gas side  
(Low Pressure)  
2-way valve at Liquid side  
(High Pressure)

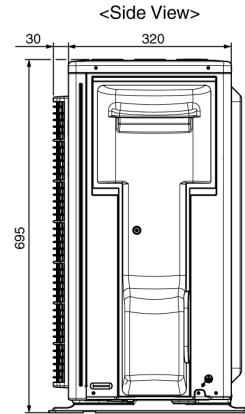

# 5. Refrigeration Cycle Diagram

## 5.1 CU-E9PFE CU-E12PFE

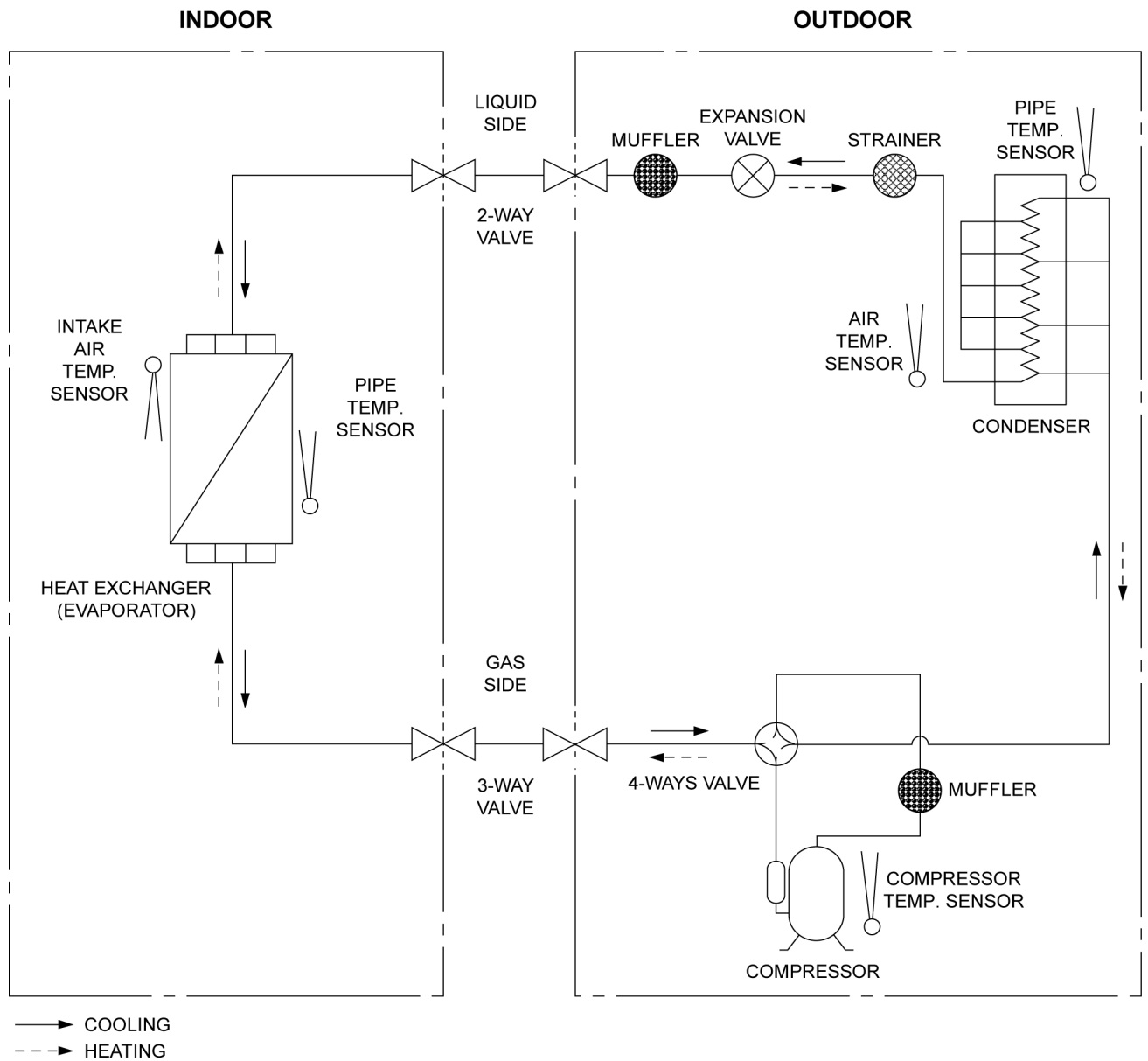

## 5.2 CU-E18PFE

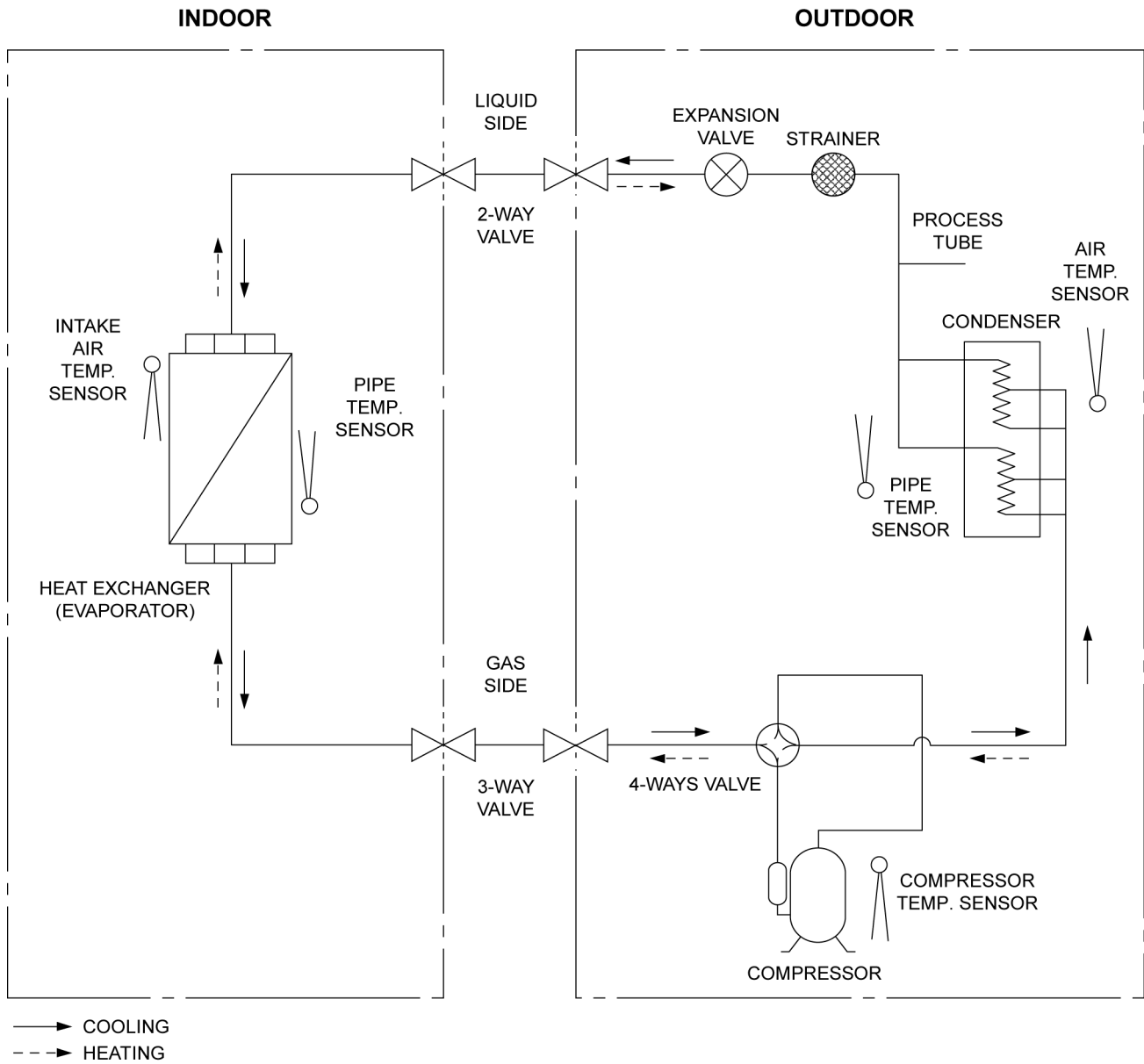

# 6. Block Diagram

## 6.1 CU-E9PFE CU-E12PFE

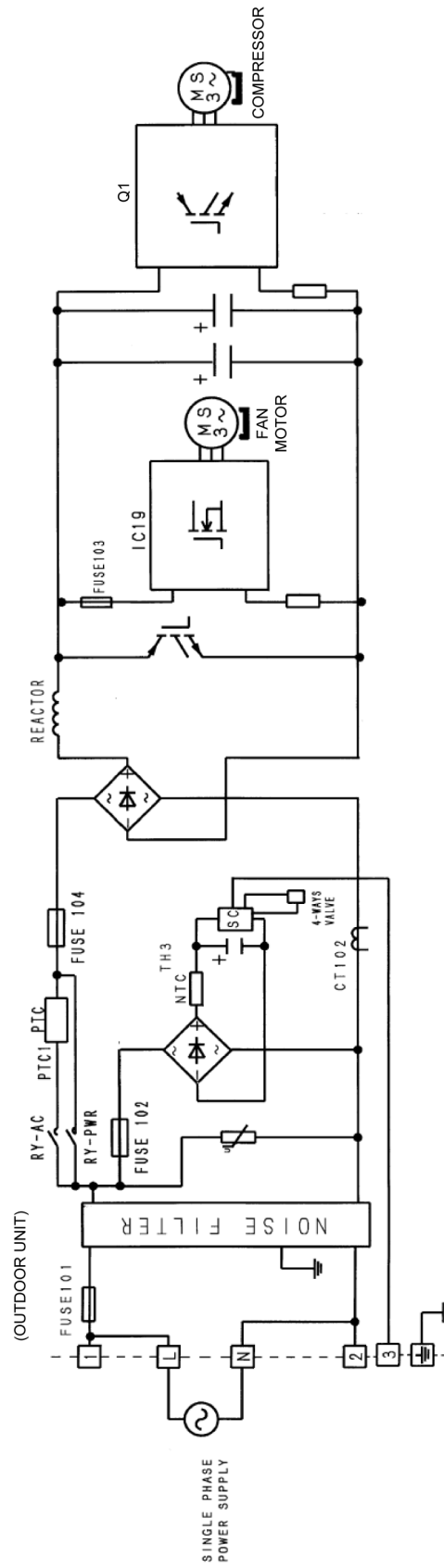

## 6.2 CU-E18PFE

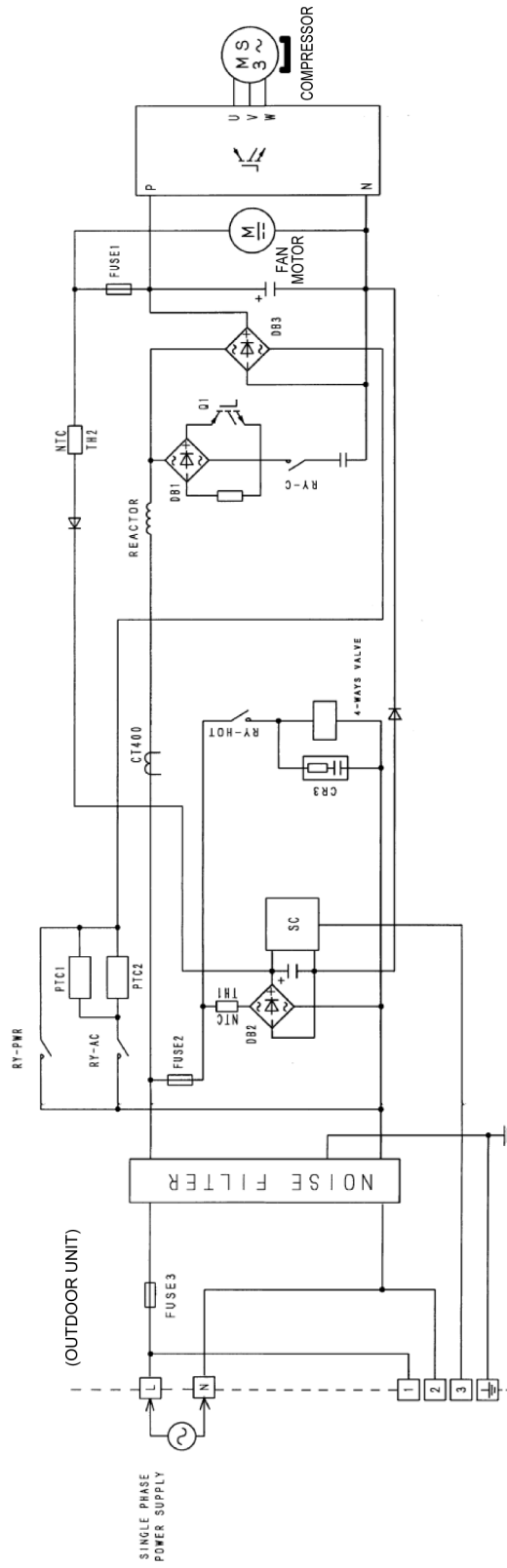



# 7. Wiring Connection Diagram

## 7.1 Outdoor Unit

### 7.1.1 CU-E9PFE CU-E12PFE

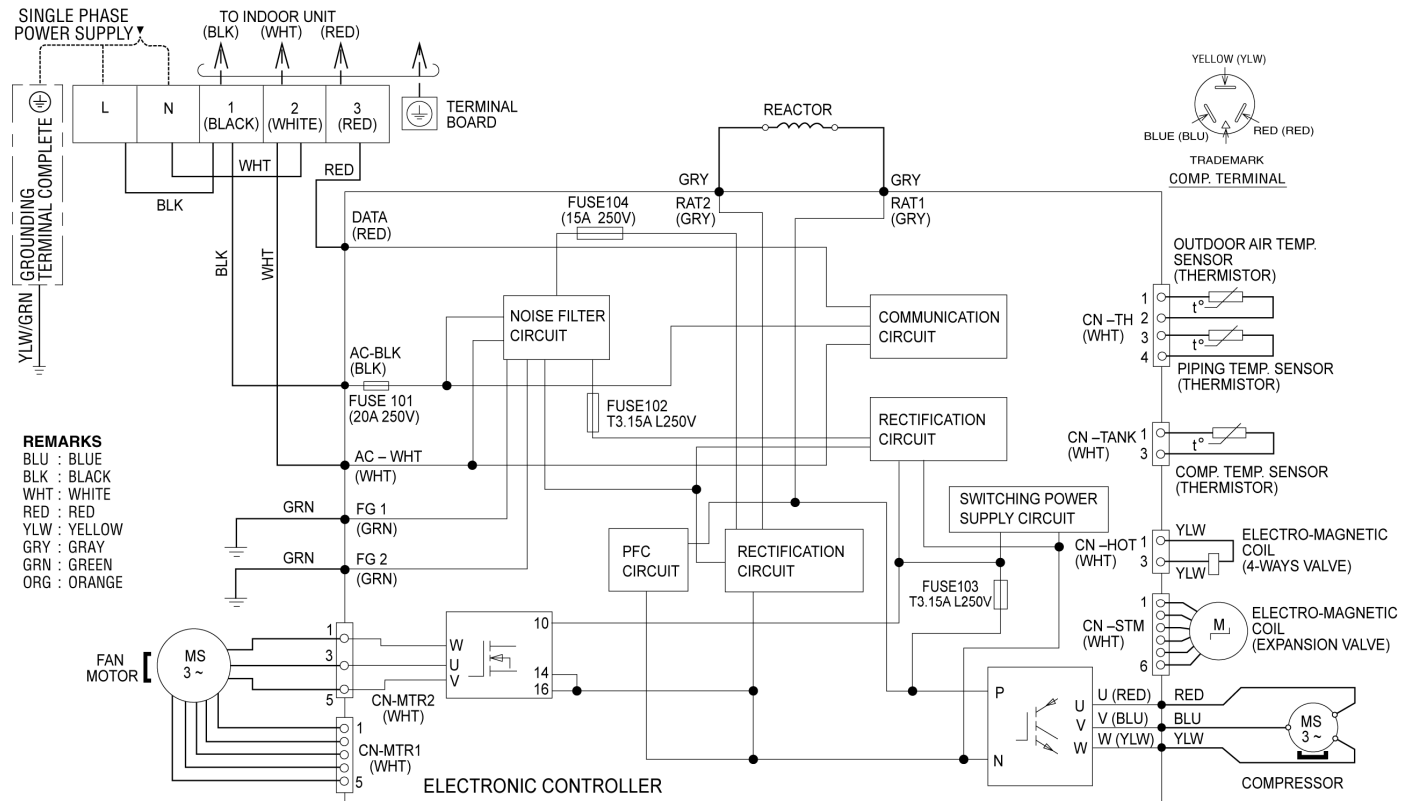

Resistance of Compressor Windings

MODEL	CU-E9PFE
CONNECTION	5RS102XBC21 (Ω)
U-V	0.858
U-W	0.858
V-W	0.858

Note: Resistance at 20°C of ambient temperature.

Resistance of Compressor Windings

MODEL	CU-E12PFE
CONNECTION	5RS102XNA21 (Ω)
U-V	1.211
U-W	1.211
V-W	1.211

Note: Resistance at 20°C of ambient temperature.

## 7.1.2 CU-E18PFE

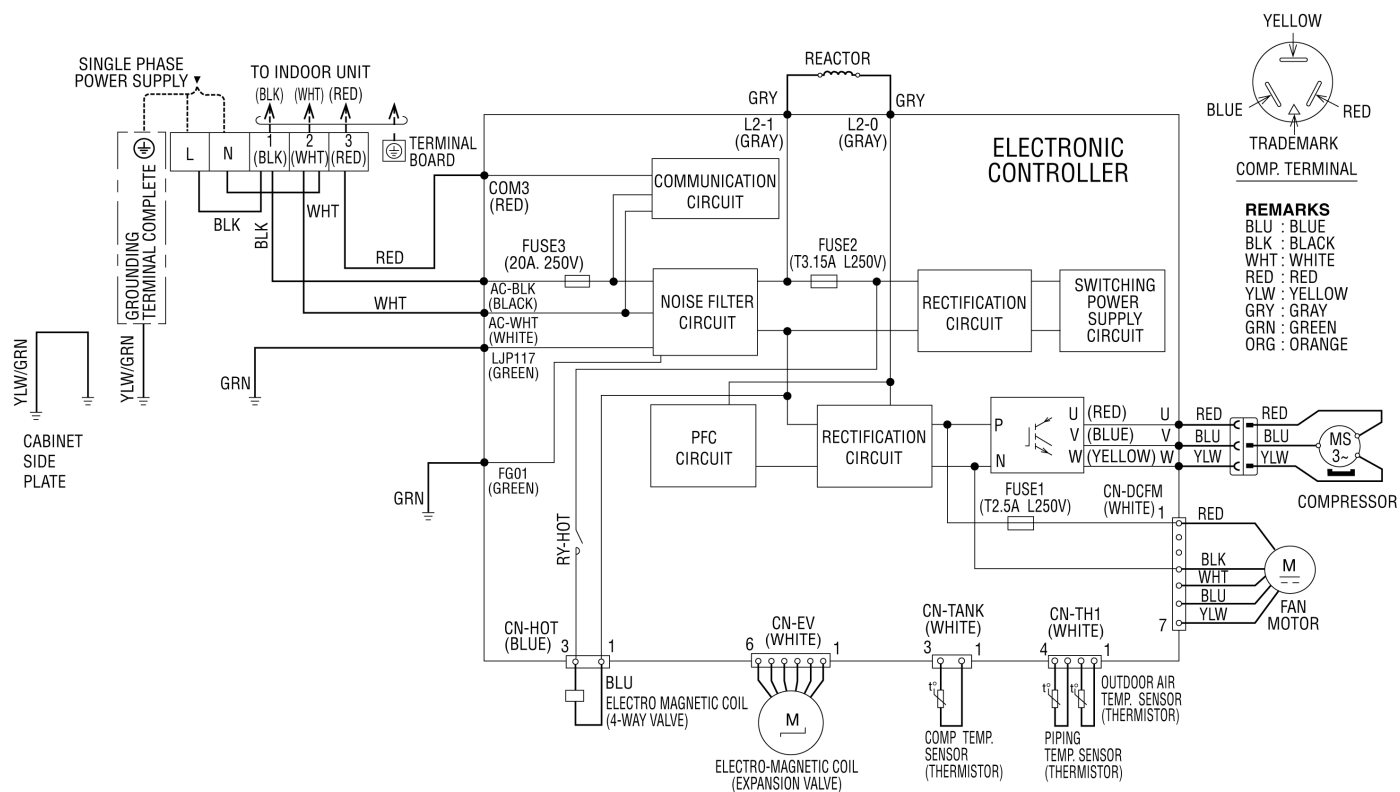

### Resistance of Compressor Windings

MODEL	CU-E18PFE
CONNECTION	5RD132XBA21 (Ω)
U-V	1.897
U-W	1.907
V-W	1.882

Note: Resistance at 20°C of ambient temperature.

# 8. Electronic Circuit Diagram

## 8.1 Outdoor Unit

### 8.1.1 CU-E9PFE CU-E12PFE

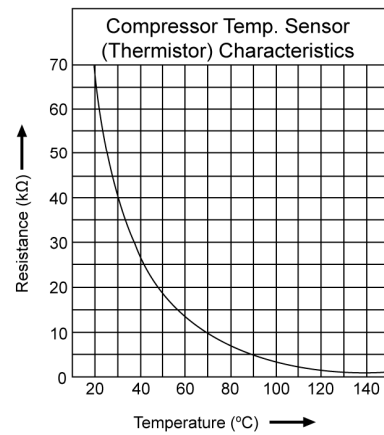
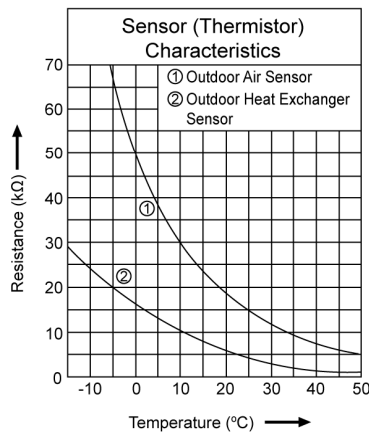
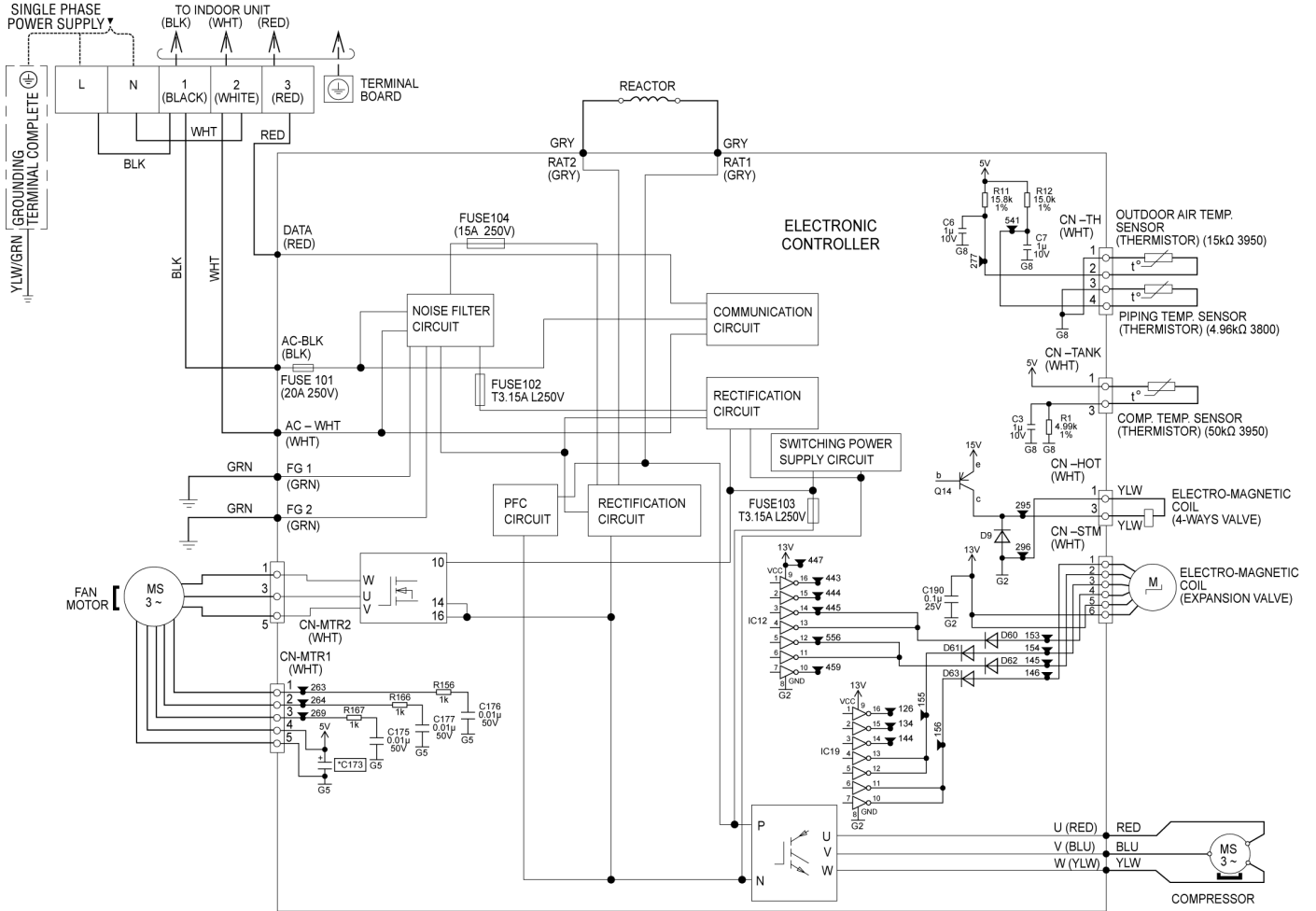

# 8.1.2 CU-E18PFE

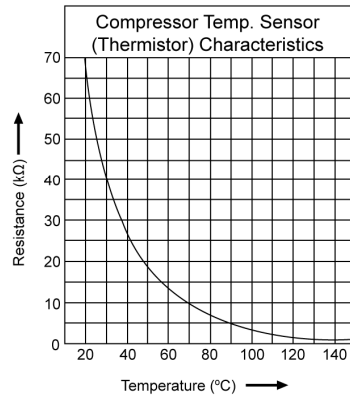
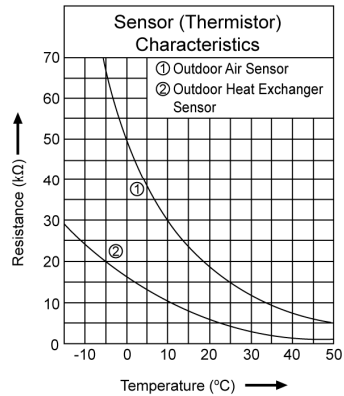
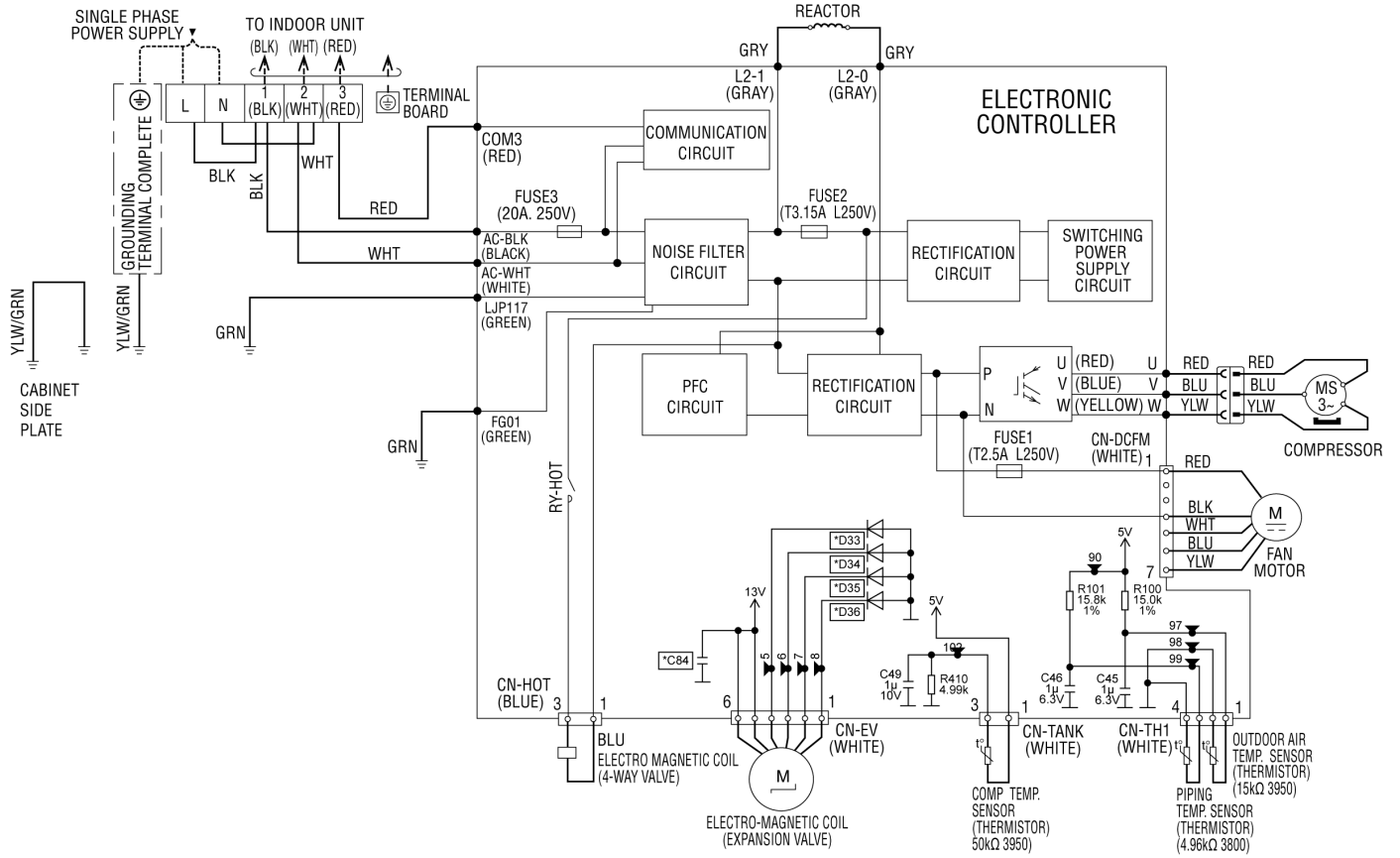



9.1.2 CU-E12PFE

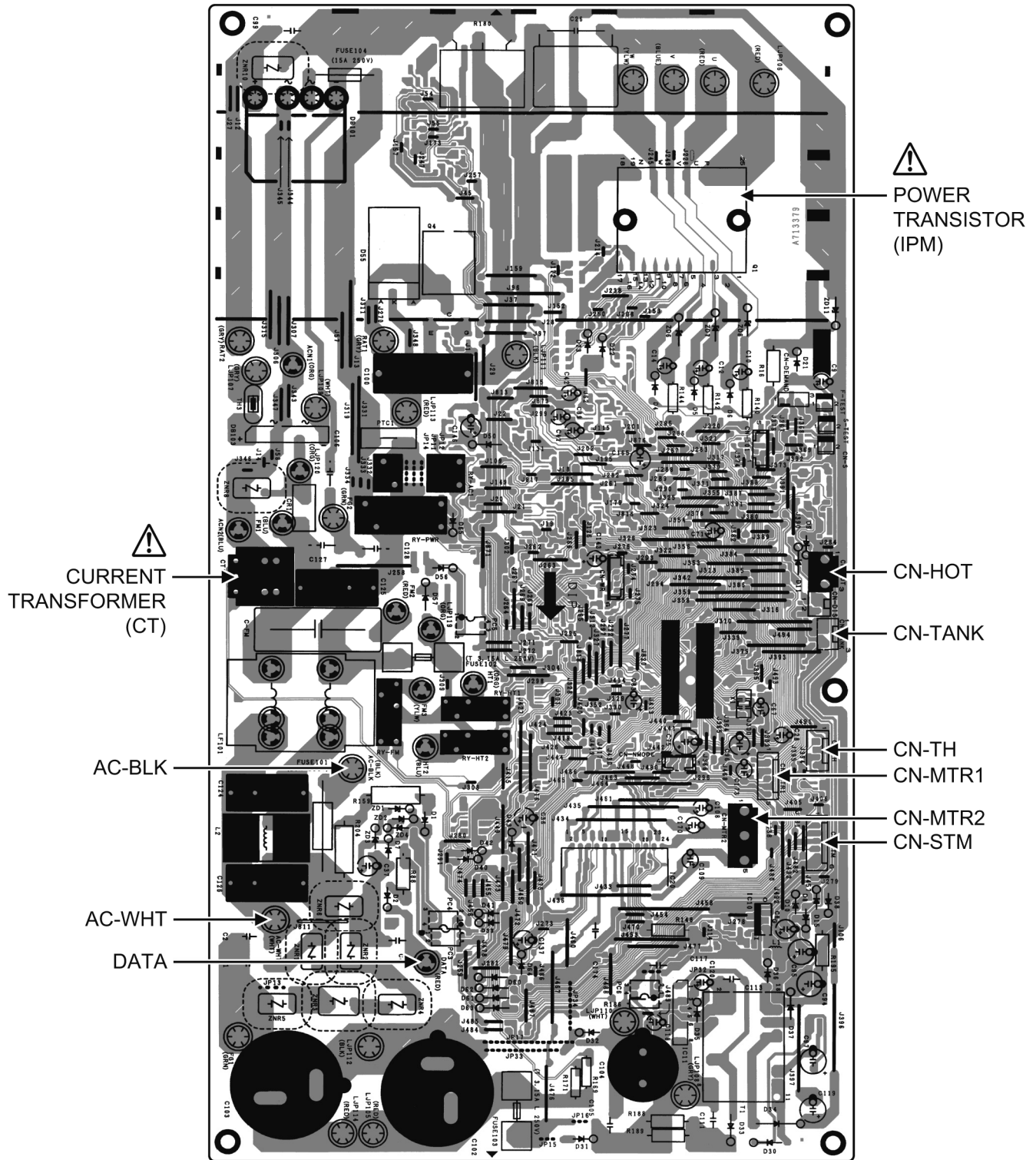

9.1.3 CU-E18PFE

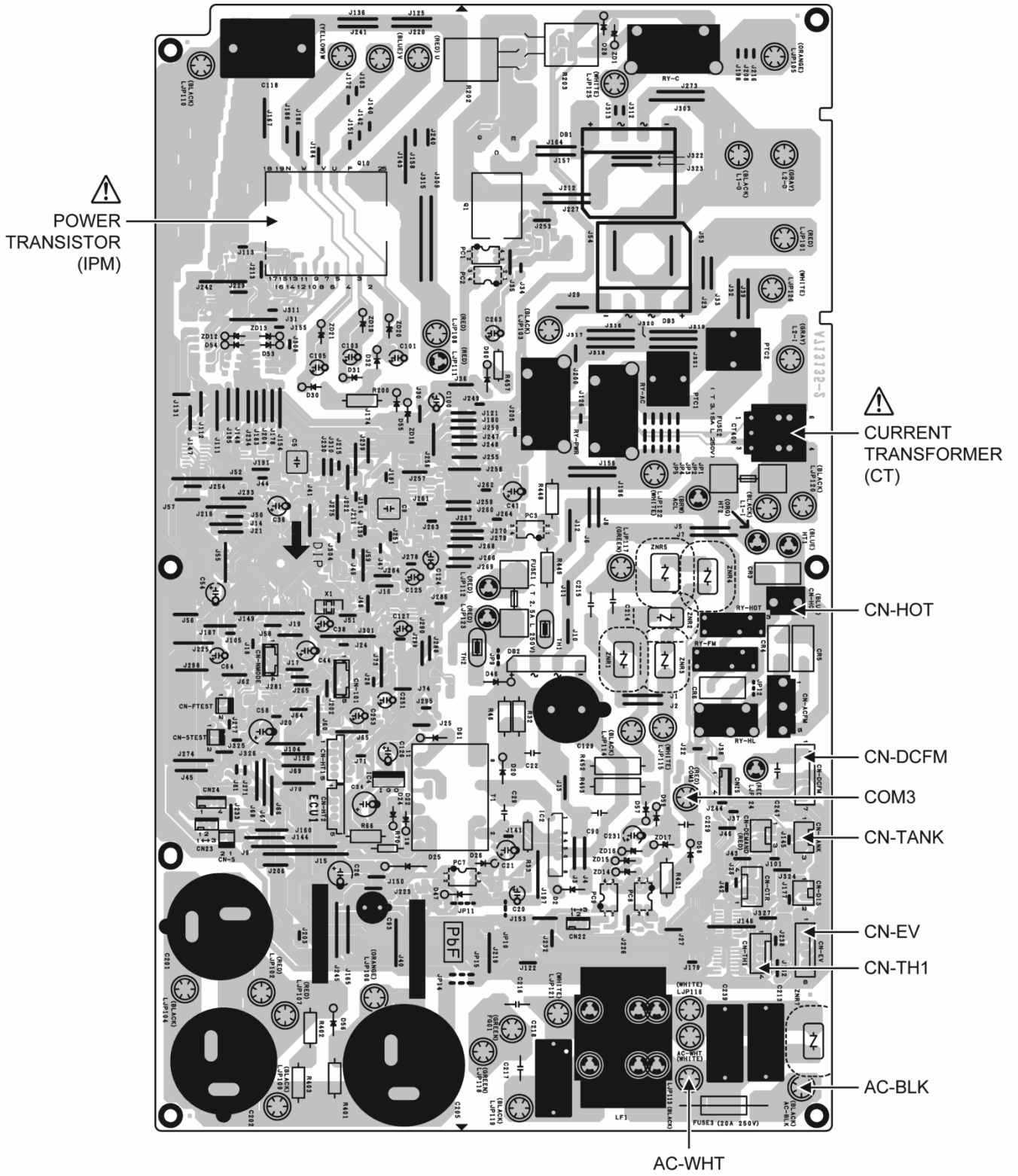

# 10. Installation Instruction

## 10.1 Indoor Unit

### 10.1.1 Selecting the Installation Location

#### Indoor Unit

Before choosing the installation site, obtain user approval.

- Do not install the unit in excessive oil fume area such as kitchen, workshop and etc.
- There should not be any heat source or steam near the unit.
- There should not be any obstacles blocking the air circulation.
- A place where air circulation in the room is good.
- A place where drainage can be easily done.
- A place where noise prevention is taken into consideration.
- Do not install the unit near the door way.
- Locate the indoor unit at least 1 m or more from TV, radio, wireless equipment, antenna cables and fluorescent light, and 2 m or more away from a telephone.
- Ensure the spaces indicated by arrows from the wall, ceiling, fence or other obstacles.

#### 10.1.1.1 Installation diagram

- The indoor unit may be mounted in any of three styles shown here.

Exposed		Half concealed	Concealed
	 Mounting Plate ① Molding		
Floor Installation	Wall Installation		Grid (field supply)

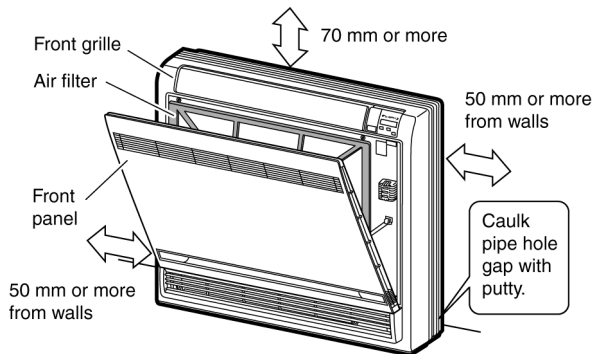

- Location for securing the mounting panel.

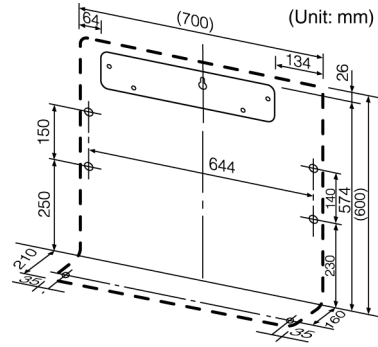

#### 10.1.1.2 Remote control

- Signals may not be transmitted and received correctly when the remote controller is operated while in the holder. Take the remote controller in your hand to operate the unit.
- Mount the holder in a location that is not subject to the effects of heat (direct sunlight and stoves, etc.).

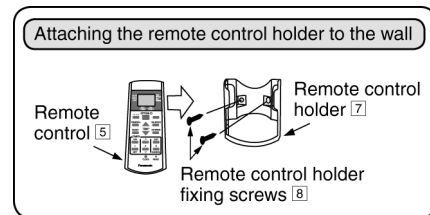



## 10.1.2 Selection of Pipe and Heat Insulation Materials

- When using commercial copper pipes and fittings, observe the following:
  - 1 Insulation material: Polyethylene foam  
Heat transfer rate: 0.041 to 0.052 W/mK (0.035 to 0.045kcal/mh°C)  
Refrigerant gas pipe's surface temperature reaches 110°C max.  
Choose heat insulation materials that will withstand this temperature.
  - 2 Be sure to insulate both the gas and liquid piping and to provide insulation dimension as below.

Model		Pipe Dimension	Thermal Insulation Dimension
E9***	Gas side	3/8" (Outer diameter 9.5 mm t0.8 mm)	Inner diameter 12 - 15 mm t10 mm Min
E12***	Liquid side	1/4" (Outer diameter 6.4 mm t0.8 mm)	Inner diameter 8 - 10 mm t10 mm Min
E18***	Gas side	1/2" (Outer diameter 12.7 mm t0.8 mm)	Inner diameter 14 - 16 mm t10 mm Min
	Liquid side	1/4" (Outer diameter 6.4 mm t0.8 mm)	Inner diameter 8 - 10 mm t10 mm Min

- 3 Use separate heat insulation pipes for gas and liquid refrigerant pipes.

## 10.1.3 Installing the Indoor Unit

### 10.1.3.1 Exposed installation

#### 10.1.3.1.1 Refrigerant piping

- 1 Drill a hole (70 mm in diameter) in the spot indicated by the ⊗ symbol in the illustration as below.
- 2 The location of the hole is different depending on which side of the pipe is taken out.
- 3 For piping, see **10.1.5 Connecting the refrigerant piping**.
- 4 Allow space around the pipe for an easier indoor unit pipe connection.

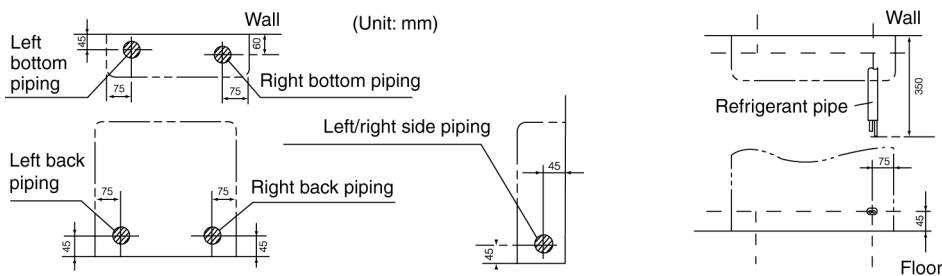

#### CAUTION

##### Min. allowable length

- The suggested shortest pipe length is 2.5 m, in order to avoid noise from the outdoor unit and vibration. (Mechanical noise and vibration may occur depending on how the unit is installed and the environment in which it is used.)
- See the installation manual for the outdoor unit for the maximum pipe length.
- For multi-connections, see the installation manual for the multi-outdoor unit.

#### 10.1.3.1.2 To drill a hole in the wall and install a sleeve of piping

- 1 Insert the piping sleeve to the hole.
- 2 Fix the bushing to the sleeve.
- 3 Cut the sleeve until it extrudes about 15 mm from the wall.

	<b>CAUTION</b>
<p>When the wall is hollow, please be sure to use the sleeve for tube assembly to prevent dangers caused by mice biting the connection cable.</p>	

- 4 Finish by sealing the sleeve with putty or caulking compound at the final stage.

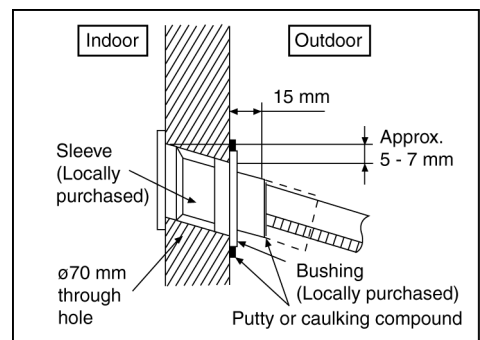

### 10.1.3.1.3 Drain piping

- 1 Use commercial rigid polyvinyl chloride pipe (general VP-20 pipe, outer diameter 26 mm, inner diameter 20 mm) for the drain pipe.
- 2 The drain hose (outer diameter 18 mm at connecting end, 220 mm long) is supplied with the indoor unit. Prepare the drain pipe picture below position.
- 3 The drain pipe should be inclined downward so that water will flow smoothly without any accumulation. (Should not be trap.)
- 4 Insert the drain hose to this depth so it won't be pulled out of the drain pipe.
- 5 Insulate the indoor drain pipe with 10 mm or more of insulation material to prevent condensation.
- 6 Remove the air filters and pour some water into the drain pan to check the water flows smoothly.

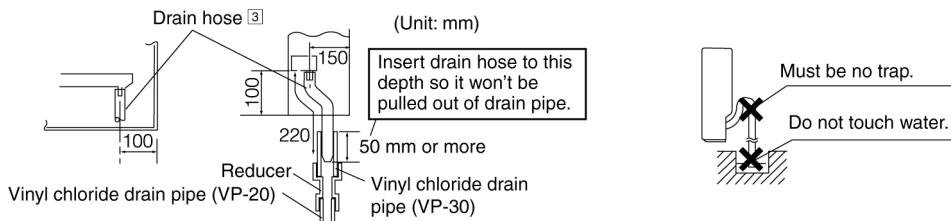

<b>CAUTION</b>	
	Use polyvinyl chloride adhesive agent for gluing. Failure to do so may cause water leakage.

### 10.1.3.1.4 Indoor unit preparation

- Open the front panel, remove the 4 screws and dismount the front grille.
- Follow the procedure below when removing the slit portions.
- **For Moldings**
  - Remove the slit portions on the bottom frame using nippers.
- **For Side Piping**
  - 1 Remove the 7 screws.
  - 2 Remove the upper casing (2 tabs).
  - 3 Remove the left and right casings (2 tabs on each side).
  - 4 Remove the slit portions on the bottom frame and casings using nippers.
  - 5 Return by following the steps in reverse order (3 > 2 > 1).

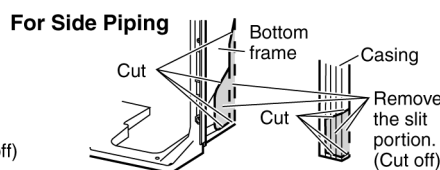
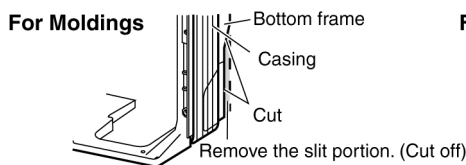
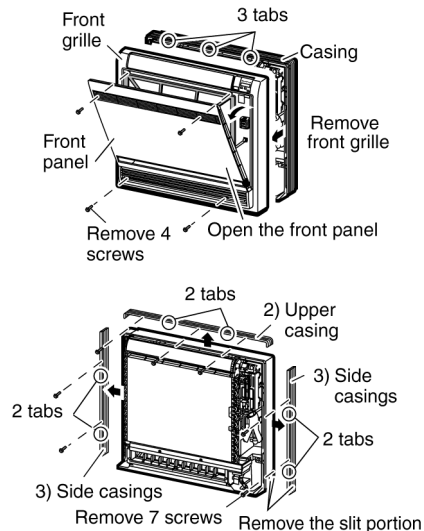

- Connect the Drain Hose  
See 10.1.4 Connecting the Drain Hose

### 10.1.3.1.5 Indoor unit installation

- Secure using 6 screws for floor installations. (Do not forget to secure to the rear wall.)
- For wall installations, secure the mounting plate <sup>1</sup> using 5 screws and the indoor unit using 4 screws.
- The mounting plate should be installed on a wall which can support the weight of the indoor unit.
  - 1 Temporarily secure the mounting plate to the wall, make sure that the panel is completely level, and mark the boring points on the wall.
  - 2 Secure the mounting plate to the wall with screws.

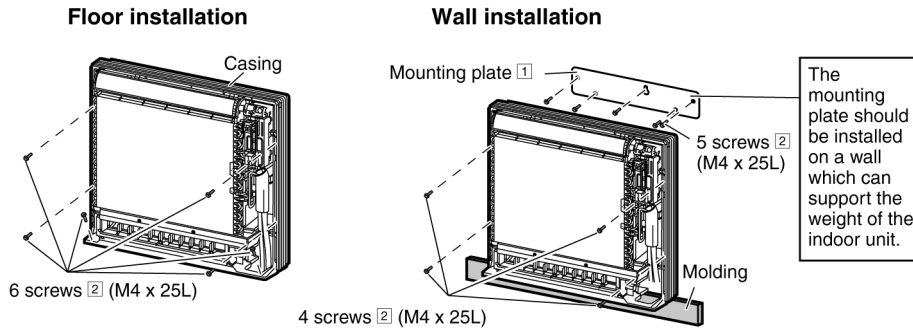

- 3 Once refrigerant piping and drain piping connections are complete, fill in the gap of the through hole with putty. A gap can lead to condensation on the refrigerant pipe, and drain pipe, and the entry of insects into the pipes.
- 4 Attach the front panel and front grille in their original positions once all connections are complete.

### 10.1.3.2 Half concealed installation

- Only item peculiar to this installation method are given here. See **Exposed** installation for additional instructions.

#### 10.1.3.2.1 Wall hole

- Drill a wall hole of the size shown in the illustration on the right.

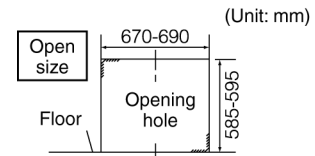

#### 10.1.3.2.2 Installation of supplemental plate for attaching indoor unit

- The rear of the unit can be fixed with screws at the points shown in the illustration as below. Be sure to install the supplemental plate in accordance with the depth of the inner wall.

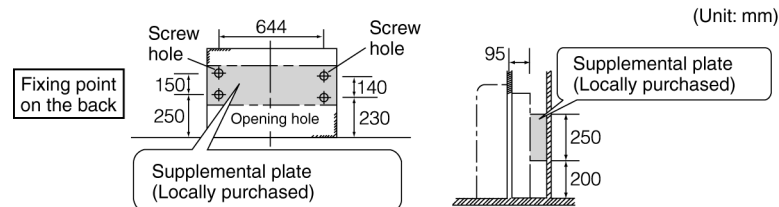

**CAUTION**

⚠ The supplemental plate for installing the main unit must be used, or there will be a gap between the unit and the wall.

#### 10.1.3.2.3 Refrigerant piping

- See **Refrigerant piping** under **Exposed Installation**.

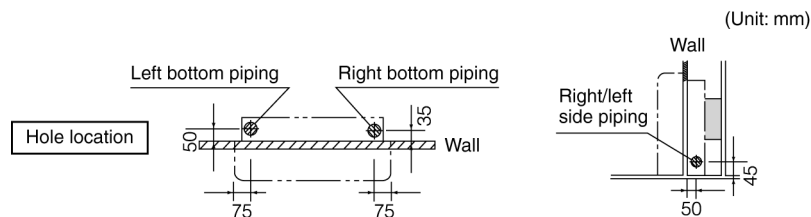

### 10.1.3.2.4 Indoor unit installation

- 1 Remove the front grille.
- 2 Remove the 7 screws.
- 3 Remove the upper casing (2 tabs).
- 4 Remove the side casings (2 tabs on each side).
- 5 Attach the indoor unit to the wall and secure using screws in 6 locations (M4 x 25L).

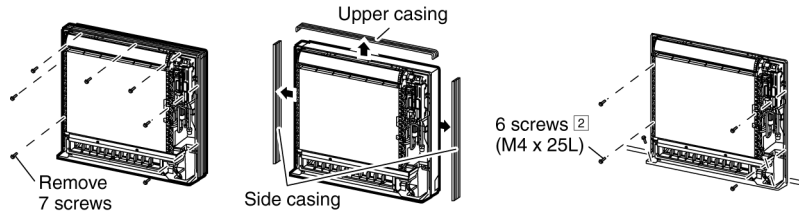

⚠ CAUTION	
❗	1 Use drain pan edge for horizontal projection of the indoor unit.
	2 Install the indoor unit flush against wall.

### 10.1.3.3 Concealed installation

- Only item peculiar to this installation method are given here. See **Exposed** installation for additional instructions.

#### 10.1.3.3.1 Preparation

- **Install the unit according to the instructions below. Failure to do so may cause both cooling and heating failure and the formation of condensation inside the house.**
  - 1 Allow enough space between the main unit and ceiling not to obstruct the flow of cool/warm air.
  - 2 Place a partition plate between outlet and inlet sections.
  - 3 Place a partition plate on the right side.
  - 4 Change the upward air flow limit dipswitch.
  - 5 Use a movable lattice at the air outlet to allow the adjustment of cool/warm air flow direction.
  - 6 Lattice size should be 70% or more of open rate.

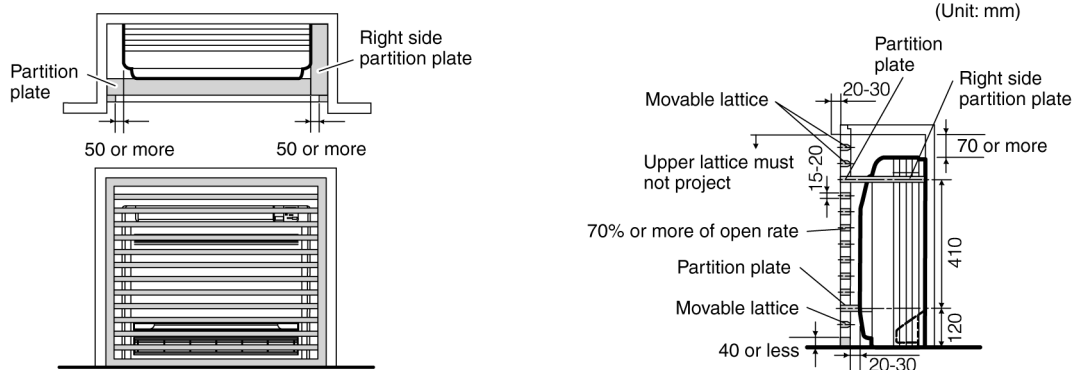

#### 10.1.3.3.2 Refrigerant piping

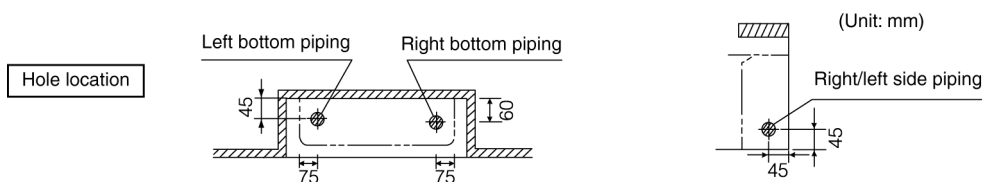

### 10.1.3.3 Changing upward air flow limit dipswitch

Change the upward air flow limit dipswitch (SW2-4) to ON to limit the upward air flow.

- 1 Remove the front grille.
- 2 Switch the dipswitch (SW2-4) on the PCB in the electrical equipment box to ON.

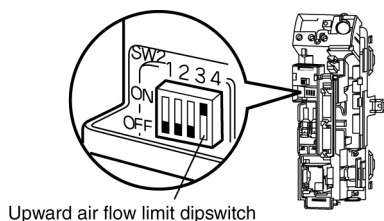

Upward air flow limit dipswitch

#### • How to set and use the switch

Switch number	SW2-4
Set function	Upward air flow limit
ON	ON
↓	↓
OFF	OFF
Use	Switch to ON for embedded units
Factory setting	OFF

#### ⚠ CAUTION

- ❗ Be sure to turn on the upward air flow limit dipswitch. Failure to do so may cause incomplete cooling/heating and formation of condensation inside the house.

### 10.1.4 Connecting the Drain Hose

- Insert the supplied drain hose ③ into the socket of the drain pan. Fully insert the drain hose until it adheres to a seal of the socket.

#### 10.1.4.1 Check the drainage

- Pour a glass of water into the drain pan.
- Ensure that water flows out from drain pipe.

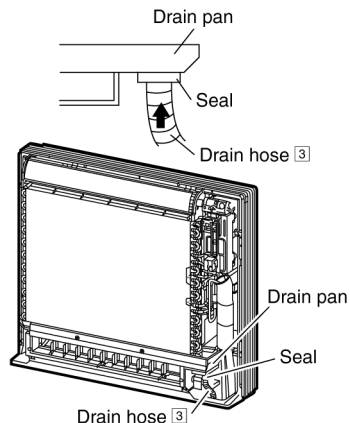
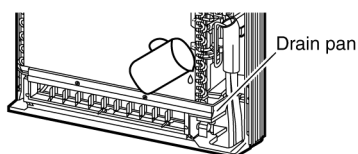

### 10.1.5 Connecting the Refrigerant Piping

- 1 Please make flare after inserting flare nut (locate at joint point of tube assembly) onto the copper pipe.
- 2 Align the center of pipe and sufficiently tighten the flare nut with fingers.
- 3 Further tighten the flare nut with torque wrench in specified torque as stated in the table. (Please refer table at "Connecting the Refrigerant Piping" in OUTDOOR UNIT).

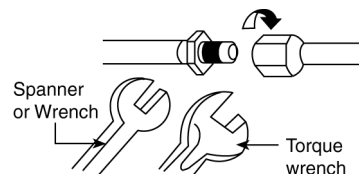

### 10.1.5.1 Checking for gas leakage

- Check for leakage of gas after air purging.

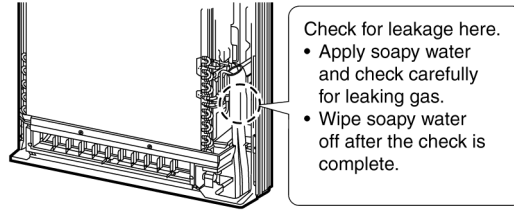

### 10.1.5.2 Insulating the refrigerant piping

- Attach the pipe after checking for gas leakage, described above.
  - 1 Cut the insulated portion of the on-site piping, matching it up with the connecting portion.
  - 2 Secure the slit on the auxiliary pipe side with the butt joint on the connection pipe using the tape, making sure there are no gaps.
  - 3 Wrap the slit and the butt joint with the included insulation sheet [4], making sure there are no gaps.

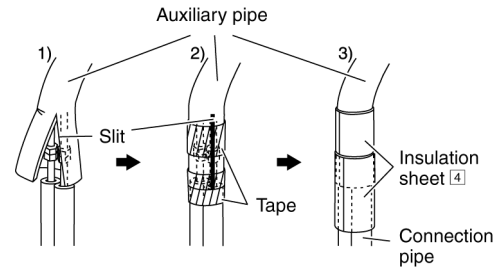

**CAUTION**

- 1) Insulate the joint of the pipes securely. Incomplete insulation may lead to water leakage.
- 2) Push the pipe inside so it does not place undue force on the front grille.

### 10.1.6 Connecting the Indoor/Outdoor Connection Cable

- 1 Leave the sensor securing plate, remove the front metal plate cover.
- 2 Connecting the cable between indoor unit and outdoor unit shall be approved polychloroprene sheathed 4 x 1.5 mm<sup>2</sup> flexible cord, type designation 60245 IEC 57 or heavier cord.
  - Ensure the colour of wires of indoor unit and the terminal Nos, are the same to the outdoor's respectively.
  - Earth lead wire shall be longer than the other lead wires as shown in the figure for the electrical safety in case of the slipping out of the cord from the anchorage.
  - Secure the cable onto the control board with the holder (clamper).

Terminals on the indoor unit	1	2	3	
Colour of wires				
Terminals on the outdoor unit	1	2	3	

**Note:**

- Secure the connection cable onto the control board with the holder.
- Ensure the colour of wires of outdoor unit and the terminal Nos. are the same to the indoor's respectively.
- Earth wire shall be Yellow/Green (Y/G) in colour and longer than other AC wires for safety reason.

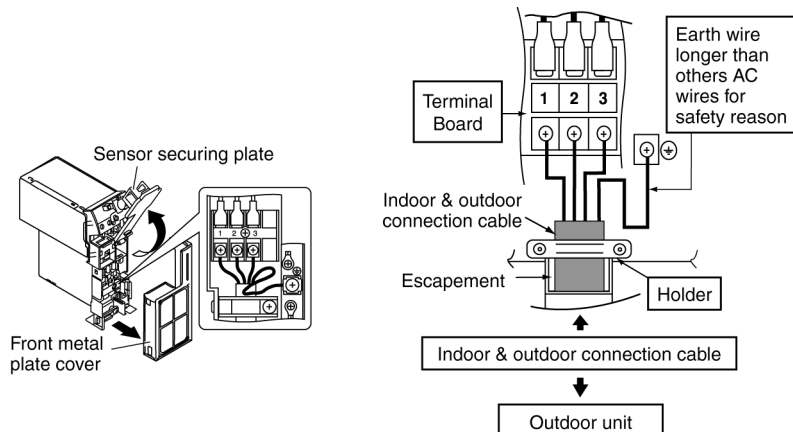

<b>WIRE STRIPPING, CONNECTING REQUIREMENT</b>  No loose strand when insert	Wire stripping 	Indoor/outdoor connection terminal board 5 mm or more (gap between wires)	Conductor fully inserted 	Conductor over inserted 	Conductor not fully inserted 	<b>WARNING</b> This equipment must be properly earthed.
				<b>ACCEPT</b>	<b>PROHIBITED</b>	

<b>WARNING</b> 	<b>RISK OF FIRE</b> JOINING OF WIRES MAY CAUSE OVERHEATING AND FIRE.	
--------------------	---	--

⊘ Do not joint wires

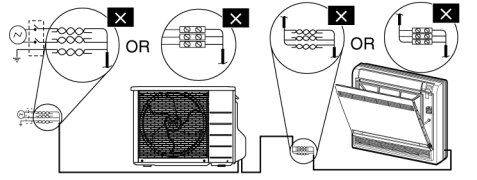

- ❗ Use complete wire without joining.
- ❗ Use approved socket and plug with earth pin.
- ❗ Wire connection in this area must follow to national wiring rules.

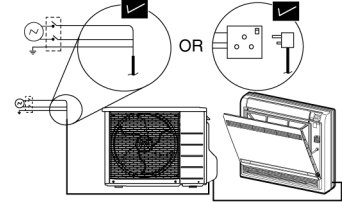

## 10.2 Outdoor Unit

### 10.2.1 Selecting the Installation Location

Before choosing the installation site, obtain user approval.

- If an awning is built over the unit to prevent direct sunlight or rain, be careful that heat radiation from the condenser is not obstructed.
- There should not be any animal or plant which could be affected by hot air discharged.
- Keep the spaces indicated by arrows from the wall, ceiling, fence or other obstacles.
- Do not place any obstacles which may cause a short circuit of the discharged air.
- If piping length is over the [piping length for additional gas], additional refrigerant should be added as shown in the table.

Model	Horse Power (HP)	Piping size		Std. Length (m)	Max. Elevation (m)	Min. Piping Length (m)	Max. Piping Length (m)	Additional Refrigerant (g/m)	Piping Length for add. gas (m)
		Gas	Liquid						
E9***	1.0HP	9.52mm (3/8")	6.35mm (1/4")	5	5	3	15	20	7.5
E12***	1.5HP	12.7mm (1/2")			5	3	15	20	7.5
E18***	2.0HP				15	3	20	20	7.5

Example: For E9\*\*\*

If the unit is installed at 10 m distance, the quantity of additional refrigerant should be 50 g .... (10-7.5) m x 20 g/m = 50 g.

#### 10.2.1.1 Installation diagram

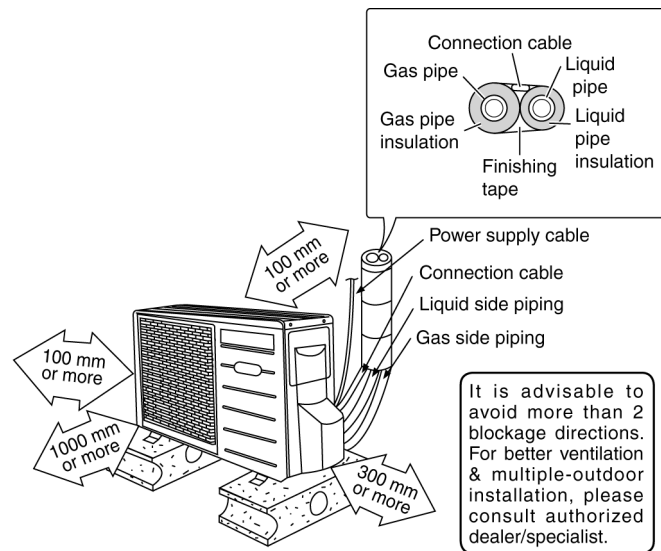

- This illustration is for explanation purposes only. The indoor unit will actually face a different way.

### 10.2.2 Installing the Outdoor Unit

- After selecting the best location, start installation to Indoor/Outdoor Unit Installation Diagram.
  - 1 Fix the unit on concrete or rigid frame firmly and horizontally by bolt nut (ø10 mm).
  - 2 When installing at roof, please consider strong wind and earthquake. Please fasten the installation stand firmly with bolt or nails.

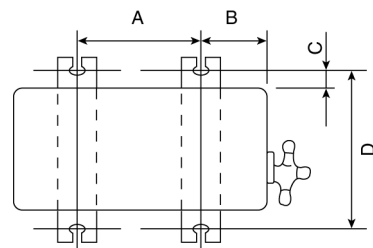

Model	A	B	C	D
E9***	570 mm	105 mm	18.5 mm	320 mm
E12***	540 mm	160 mm	18.5 mm	330 mm
E18***	613 mm	131 mm	16 mm	360.5 mm



### 10.2.3 Connecting the Refrigerant Piping

- 1 Decide piping length and then cut by using pipe cutter. Remove burrs from cut edge.
- 2 Make flare after inserting the flare nut (locate at valve) onto the copper pipe.
- 3 Align center of pipe to valve and then tighten with torque wrench to the specified torque as stated in the table.

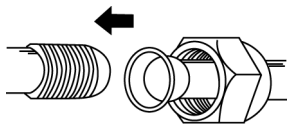

Do not overtighten, overtightening may cause gas leakage	
Piping size	Torque
6.35 mm (1/4")	[18 N•m (1.8 kgf.m)]
9.52 mm (3/8")	[42 N•m (4.3 kgf.m)]
12.7 mm (1/2")	[55 N•m (5.6 kgf.m)]
15.88 mm (5/8")	[65 N•m (6.6 kgf.m)]
19.05 mm (3/4")	[100 N•m (10.2 kgf.m)]

#### 10.2.3.1 Flaring the pipe end

- 1 Please cut using pipe cutter and then remove the burrs.
- 2 Remove the burrs by using reamer. If burrs is not removed, gas leakage may be caused. Turn the piping end down to avoid the metal powder entering the pipe.
- 3 Please make flare after inserting the flare nut onto the copper pipes.

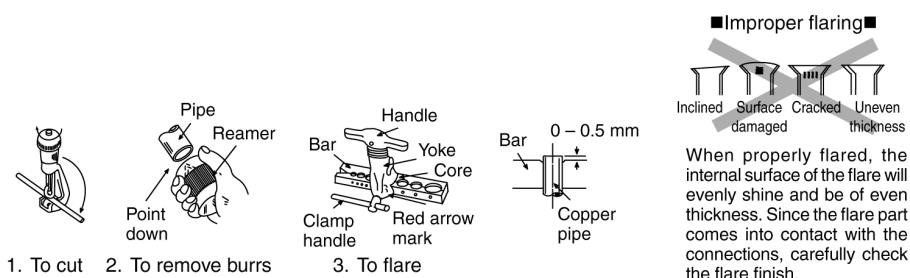

### 10.2.4 Evacuation of the Equipment

WHEN INSTALLING AN AIR CONDITIONER, BE SURE TO EVACUATE THE AIR INSIDE THE INDOOR UNIT AND PIPES in the following procedure.

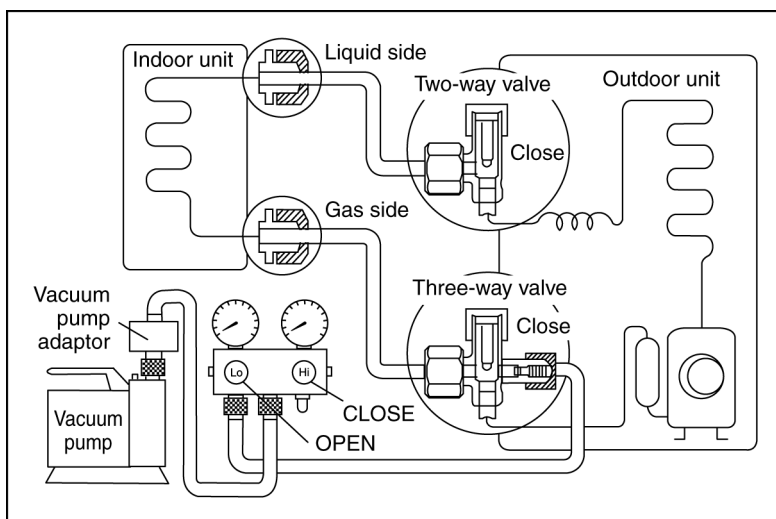

- 1 Connect a charging hose with a push pin to the Low side of a charging set and the service port of the 3-way valve.
  - o Be sure to connect the end of the charging hose with the push pin to the service port.
- 2 Connect the center hose of the charging set to a vacuum pump with check valve, or vacuum pump and vacuum pump adaptor.
- 3 Turn on the power switch of the vacuum pump and make sure that the needle in the gauge moves from 0 cmHg (0 MPa) to -76 cmHg (-0.1 MPa). Then evacuate the air approximately ten minutes.
- 4 Close the Low side valve of the charging set and turn off the vacuum pump. Make sure that the needle in the gauge does not move after approximately five minutes.

Note : BE SURE TO FOLLOW THIS PROCEDURE IN ORDER TO AVOID REFRIGERANT GAS LEAKAGE.

- 5 Disconnect the charging hose from the vacuum pump and from the service port of the 3-way valve.
- 6 Tighten the service port caps of the 3-way valve at a torque of 18 N•m with a torque wrench.
- 7 Remove the valve caps of both of the 2-way valve and 3-way valve. Position both of the valves to “OPEN” using a hexagonal wrench (4 mm).
- 8 Mount valve caps onto the 2-way valve and the 3-way valve.
  - Be sure to check for gas leakage.

- If gauge needle does not move from 0 cmHg (0 MPa) to -76 cmHg (-0.1 MPa), in the step ③ above take the following measure:
  - If the leak stops when the piping connections are tightened further, continue working from step ③.
  - If the leak does not stop when the connections are retightened, repair location of leak.
  - Do not release refrigerant during piping work for installation and reinstallation.
  - Take care of the liquid refrigerant, it may cause frostbite.

## 10.2.5 Connecting the Cable to Outdoor Unit

- 1 Remove the control board cover from the unit by loosening the screw.
- 2 Cable connection to the power supply through Isolating Devices (Disconnecting means).
  - Connect approved type polychloroprene sheathed **power supply cord** 3 x 1.5 mm<sup>2</sup> (1.0 ~ 1.5HP), 3 x 2.5 mm<sup>2</sup> (2.0 HP) type designation 60245 IEC 57 or heavier cord to the terminal board, and connect the others end of the cord to Isolating Devices (Disconnecting means).
- 3 **Connection cable** between indoor unit and outdoor unit shall be approved polychloroprene sheathed 4 x 1.5 mm<sup>2</sup> flexible cord, type designation 60245 IEC 57 or heavier cord.
- 4 Connect the power supply cord and connection cable between indoor unit and outdoor unit according to the diagram below.

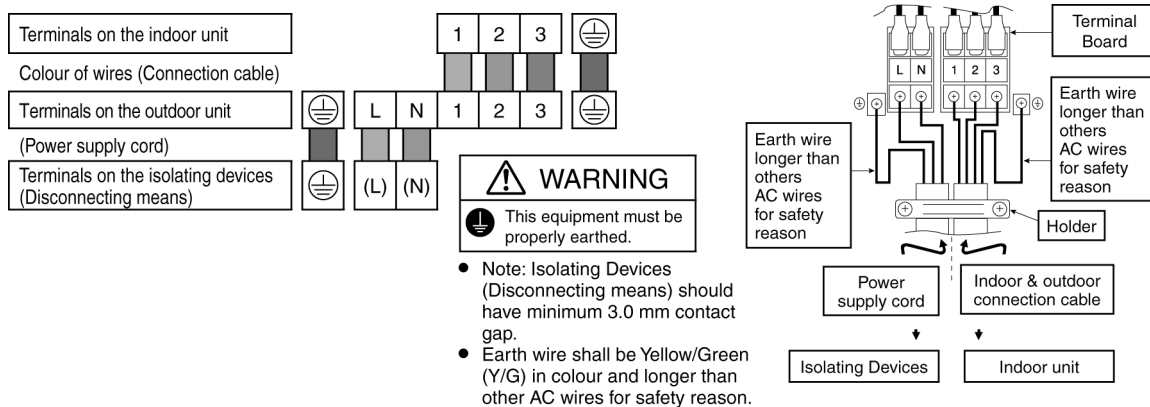

- 5 Secure the power supply cord and connection cable onto the control board with the holder.
- 6 Attach the control board cover back to the original position with screw.
- 7 For wire stripping and connection requirement, refer to instruction 10.1.6 of indoor unit.

## 10.2.6 Piping insulation

- Please carry out insulation at pipe connection portion as mentioned in Installation diagram under outdoor unit.
- Please wrap insulated pipe end to prevent it water from going inside the piping.

## 10.2.7 Disposal of drain water

- If drain elbow is used, the unit should be placed on a stand which is taller than 3 cm.
- If the unit is used in an area where temperature falls below 0°C for 2 or 3 days in succession, it is recommended not to use a drain elbow, for the drain water freezes and the fan will not rotate.

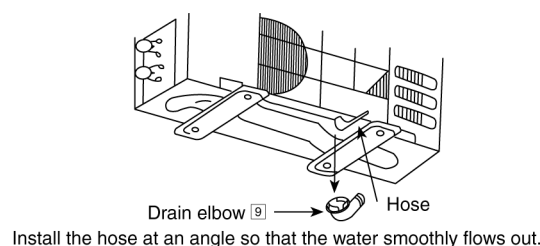

### 10.2.8 Auto switch operation

- The following operations can be performed by pressing the "AUTO" switch.
  - 1 AUTO OPERATION MODE  
The Auto operation will be activated immediately once the Auto Switch is pressed.
  - 2 TEST RUN OPERATION (FOR PUMP DOWN/SERVICING PURPOSE)  
The Test Run operation will be activated if the Auto Switch is pressed continuously for more than 5 sec. to below 8 sec. A "pep" sound will occur at the fifth sec., in order to identify the starting of Test Run operation.

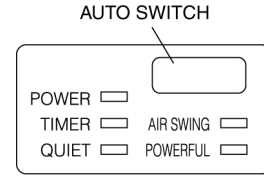

### 10.2.9 Changing the remote control transmission code

- 1 Press AUTO switch on indoor unit continuously for 11 seconds (Buzzer sound = pep pep pep)
- 2 After 11 seconds, release AUTO switch, then press remote control TIMER "▼" button continuously for 5 seconds. Reset code will be transmitted. After transmitted reset code, release TIMER "▼" button.
- 3 Press remote control "OFF/ON" button. The new remote control number will be accepted and memorized, after which the new remote control number can be used.

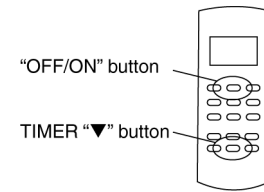

#### Remote control number change in Remote Controller

- 1 Remove battery from the battery compartment in the Remote Controller.
- 2 At left side of battery compartment, there is a small opening at the centre in which a Jumper (J\_A) can be seen. Also in remote control PCB shown below, Jumper (J\_B) can be seen.

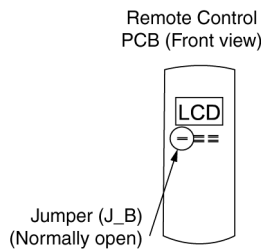
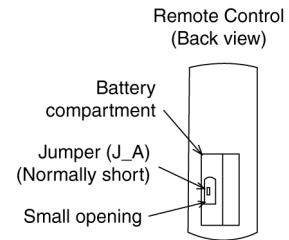

J_A	J_B	Remote control number
Short	Open	A(Default)
Open	Open	B
Short	Short	C
Open	Short	D

# 11. Protection Control

## 11.1 Protection Control For All Operations

### 11.1.1 Restart Control (Time Delay Safety Control)

- The Compressor will not turn on within 3 minutes from the moment operation stops, although the unit is turned on again by pressing OFF/ON button at remote control within this period.
- This control is not applicable if the power supply is cut off and on again.
- This phenomenon is to balance the pressure inside the refrigerant cycle.

### 11.1.2 Total Running Current

- 1 When the outdoor unit total running current (AC) exceeds X value, the frequency instructed for compressor operation will be decreased.
- 2 If the running current does not exceed X value for 5 seconds, the frequency instructed will be increased.
- 3 However, if total outdoor unit running current exceeds Y value, compressor will be stopped immediately for 3 minutes.

Model	E9PFE		E12PFE		E18PFE	
	X (A)	Y (A)	X (A)	Y (A)	X (A)	Y (A)
Cooling / Soft Dry (A)	4.25	15.09	6.30	15.09	11.10	14.75
Cooling / Soft Dry (B)	3.63		5.83		9.46	
Heating	5.18		7.27		10.07	

- 4 The first 30 minutes of cooling operation, (A) will be applied.

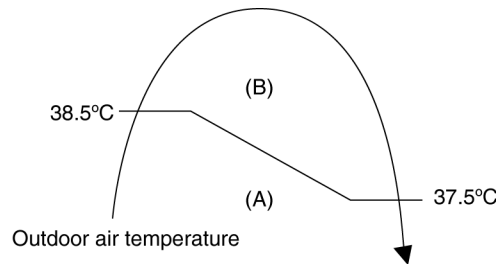

### 11.1.3 IPM (Power transistor) Prevention Control

- Overheating Prevention Control
  - 1 When the IPM temperature rises to 120°C (E/9/12/18PFE), compressor operation will stop immediately.
  - 2 Compressor operation restarts after 3 minutes the temperature decreases to 110°C.
  - 3 If this condition repeats continuously 4 times within 20 minutes, timer LED will be blinking ("F96" is indicated).
- DC Peak Current Control
  - 1 When electric current to IPM exceeds set value of 16.0 ± 2.0A (E9/12PFE) and 30.0 ± 3.0A (E18PFE), the compressor will stop operate. Then, operation will restart after 3 minutes.
  - 2 If the set value is exceeded again more than 30 seconds after the compressor starts, the operation will restart after 1 minute.
  - 3 If the set value exceeded again within 30 seconds after the compressor starts, the operation will restart after 1 minute. If this condition repeats continuously for 7 times, all indoor and outdoor relays will be cut off, timer LED will be blinking ("F99" is indicated).

### 11.1.4 Compressor Overheating Prevention Control

- Instructed frequency for compressor operation will be regulated by compressor discharge temperature. The changes of frequency are as below.
- If compressor discharge temperature exceeds 107°C, compressor will be stopped, occurs 4 times per 20 minutes, timer LED will be blinking. (“F97” is indicated.)

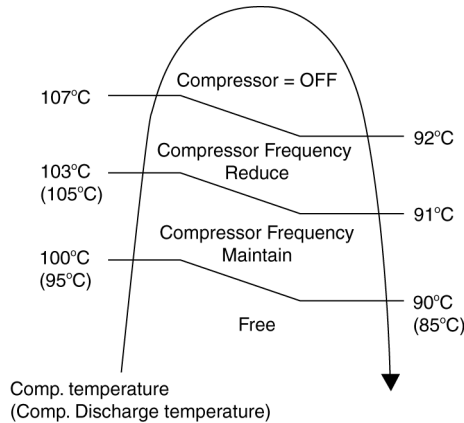

### 11.1.5 Low Pressure Prevention Control (Gas Leakage Detection)

- Control start conditions
  - For 5 minutes, the compressor continuously operates and outdoor total current is between 0.75A and 0.95A (E9/12PFE), 1.38A and 1.65A (E18PFE).
  - During Cooling and Soft Dry operations: Indoor suction temperature - indoor piping temperature is below 4°C.
  - During Heating operations : Indoor piping temperature - indoor suction is under 5°C.
- Control contents
  - Compressor stops (and restart after 3 minutes).
  - If the conditions above happen 2 times within 20 minutes, the unit will:
    - Stop operation
    - Timer LED blinks and “F91” indicated.

### 11.1.6 Low Frequency Protection Control 1

- When the compressor operate at frequency lower than 24 Hz continued for 20 minutes, the operation frequency will be changed to 23 Hz for 2 minutes.

### 11.1.7 Low Frequency Protection Control 2

- When all the below conditions comply, the compressor frequency will change to lower frequency.

Temperature, T, for:	Cooling/Soft Dry	Heating
Indoor intake air (°C)	T < 14 or T ≥ 30	T < 14 or T ≥ 28
Outdoor air (°C)	T < 13 or T ≥ 38	T < 4 or T ≥ 24
Indoor heat exchanger (°C)	T < 30	T ≥ 0

## 11.2 Protection Control For Cooling & Soft Dry Operation

### 11.2.1 Outdoor Air Temperature Control

- The compressor operating frequency is regulated in accordance to the outdoor air temperature as shown in the diagram below.
- This control will begin 1 minute after the compressor starts.
- Compressor frequency will adjust base on outdoor air temperature.

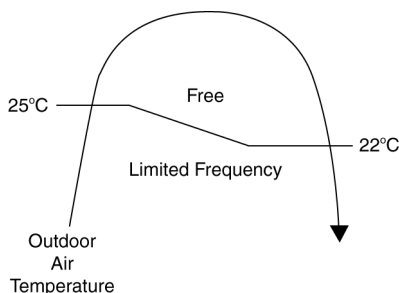

### 11.2.2 Cooling Overload Control

- Detects the Outdoor pipe temperature and carry out below restriction/limitation (Limit the compressor Operation frequency).
- The compressor stop if outdoor pipe temperature exceeds 61°C (E9/12PFE), 63°C (E18PFE).
- If the compressor stops 4 times in 20 minutes, Timer LED blinking (F95 indicated: outdoor high pressure rise protection).

### 11.2.3 Freeze Prevention Control 1

- When indoor heat exchanger temperature is lower than 0°C continuously for 6 minutes, compressor will stop operating.
- Compressor will resume its operation 3 minutes after the indoor heat exchanger is higher than 5°C.
- At the same time, indoor fan speed will be higher than during its normal operation.
- If indoor heat exchanger temperature is higher than 5°C for 5 minutes, the fan speed will return to its normal operation.

### 11.2.4 Freeze Prevention Control 2

- Control start conditions
  - During Cooling operation and soft dry operation
    - During thermo OFF condition, indoor intake temperature is less than 10°C or
    - Compressor stops for freeze prevention control
  - Either one of the conditions above occurs 5 times in 60 minutes.
- Control contents
  - Operation stops
  - Timer LED blinks and “H99” indicated

### 11.2.5 Dew Prevention Control 1

- To prevent dew formation at indoor unit discharge area.
- This control will be activated if:
  - Outdoor air temperature and Indoor pipe temperature judgment by microcontroller is fulfilled.
  - When Cooling or Dry mode is operated more than 20 minutes or more.
- This control stopped if:
  - Compressor stopped.
  - Remote control setting changed (fan speed / temperature).
  - Outdoor air temperature and indoor intake temperature changed.
- Fan speed will be adjusted accordingly in this control.

### 11.2.6 Odor Cut Control

- To reduce the odor released from the unit.
  - Start Condition
    - AUTO FAN Speed is selected during COOL or DRY operation.
    - During freeze prevention control and timer preliminary operation, this control is not applicable.
  - Control content
    - Depends on compressor conditions:
      1. Compressor OFF → Compressor ON.  
The indoor unit fan stops temporarily and then starts to blow at minimum airflow for 30 seconds.
      2. Compressor ON → Compressor OFF.  
The indoor unit fan stops for 90 seconds and then blows at minimum airflow for 20 seconds.

## 11.3 Protection Control For Heating Operation

### 11.3.1 Intake Air Temperature Control

Compressor will operate at limited freq., if indoor intake air temperature is 30°C or above.

### 11.3.2 Outdoor Air Temperature Control

- The Max current value is regulated when the outdoor air temperature rise above 14°C (E9/12PFE) and 14°C (E18PFE) in order to avoid compressor overloading.

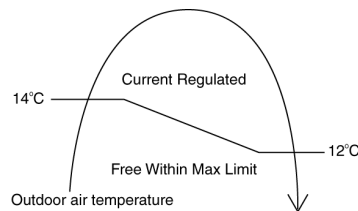

### 11.3.3 Overload Protection Control

- The compressor operating frequency is regulated in accordance to indoor heat exchanger temperature as shown below.
- If the heat exchanger temperature exceeds 60°C, compressor will stop.

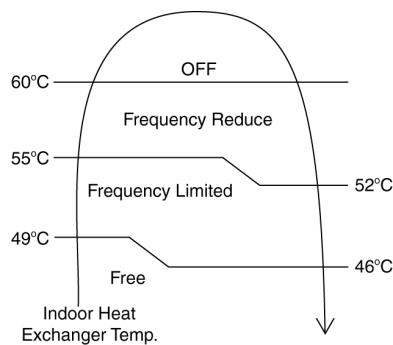

### 11.3.4 Low Temperature Compressor Oil Return Control

- In heating operation, if the outdoor temperature falls below -10°C when compressor starts, the compressor frequency will be regulated up to 600 seconds.

### 11.3.5 Cold Draught Prevention Control

- When indoor pipe temperature is low, cold draught operation starts where indoor fan speed will be reduced.

### 11.3.6 Deice Operation

- When outdoor pipe temperature and outdoor air temperature is low, deice operation start where indoor fan motor and outdoor fan motor stop and operation LED blinks.

## 12. Disassembly and Assembly Instructions



**WARNING**

High Voltage is generated in the electrical parts area by the capacitor. Ensure that the capacitor has discharged sufficiently before proceeding with repair work. Failure to heed this caution may result in electric shocks.

### 12.1 Outdoor Electronic Controller Removal Procedure

#### 12.1.1 CU-E9PFE

Caution! When handling electronic controller, be careful of electrostatic discharge.

- 1 Remove the 3 screws of the Top Panel.

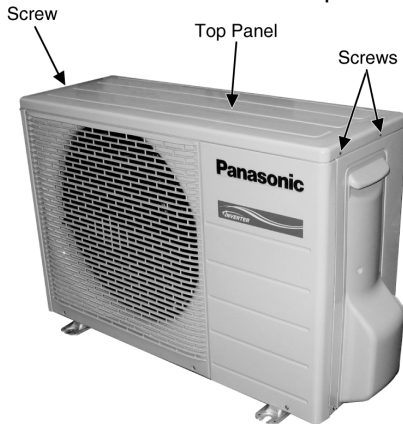

Fig. 1

- 2 Remove the 6 screws of the Front Panel.

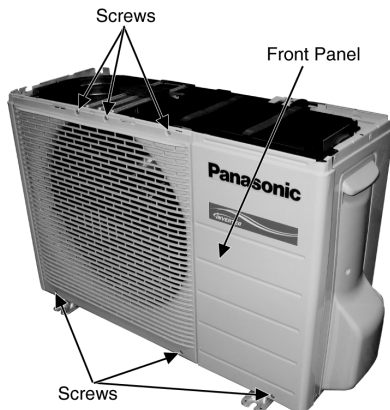

Fig. 2

- 3 Remove the screw of the Terminal Board Cover.

- 4 Remove the Top Cover of the Control Board by 4 hooks.

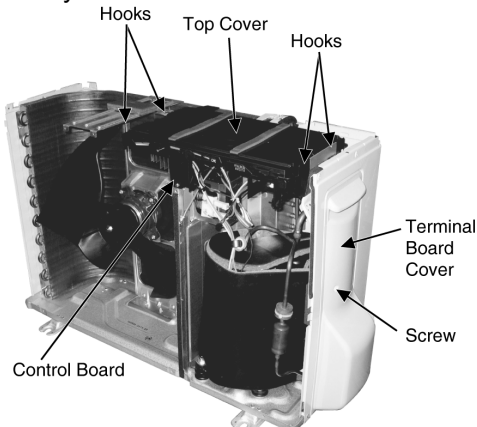

Fig. 3

- 5 Remove the Control Board as follows:

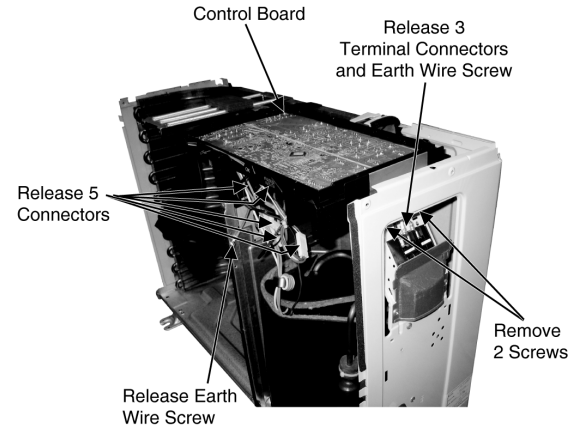

Fig. 4

Remove the Terminal Cover and 3 Terminal Compressor

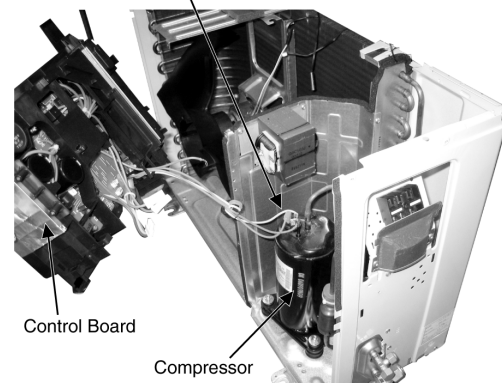

Fig. 5

Electronic Controller Control Board

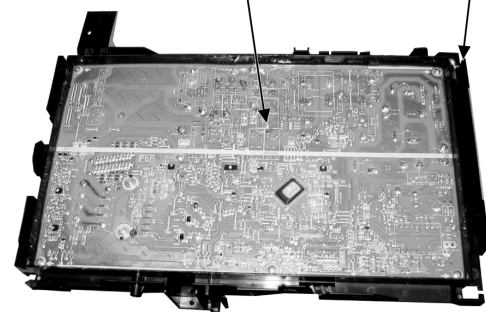

Fig. 6



## 12.1.2 CU-E12PFE

**⚠ Caution!** When handling electronic controller, be careful of electrostatic discharge.

1 Remove the 5 screws of the Top Panel.

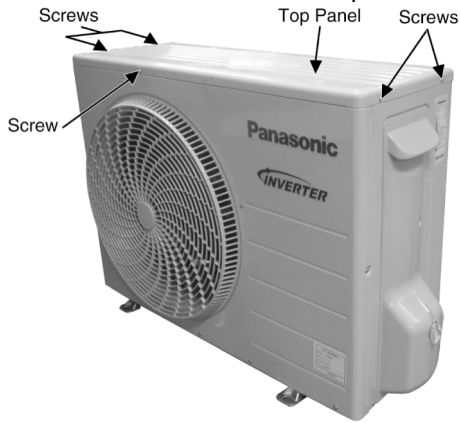

Fig. 1

2 Remove the 8 screws of the Front Panel.

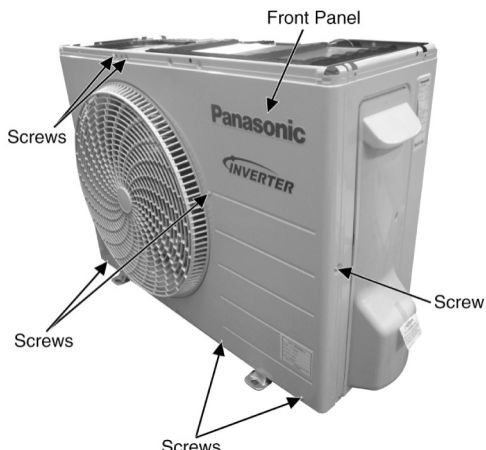

Fig. 2

3 Remove the screw of the Terminal Board Cover.

4 Remove the Top Cover of the Control Board by 4 hooks.

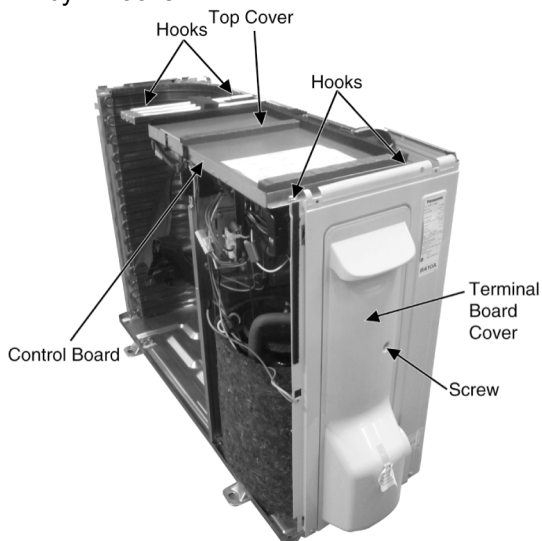

Fig. 3

5 Remove the Control Board as follows:

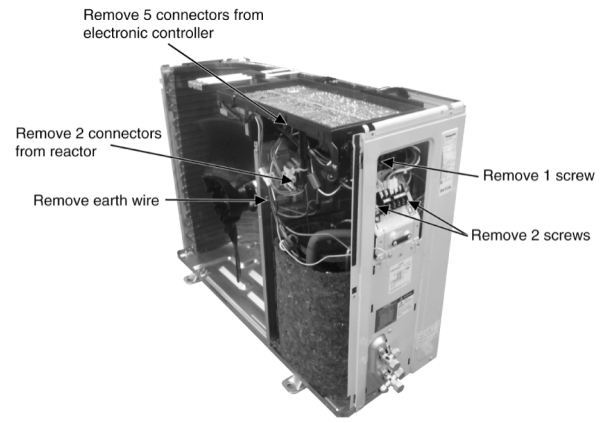

Fig. 4

Remove the Terminal Cover and 3 Terminal Compressor

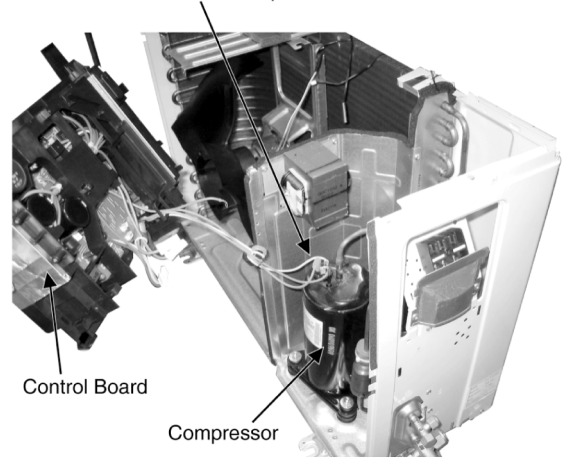

Fig. 5

Electronic Controller Control Board

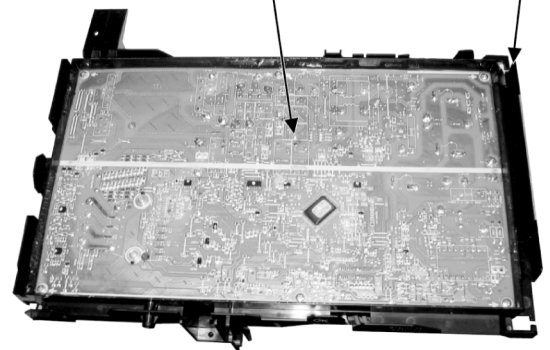

Fig. 6

### 12.1.3 CU-E18PFE

- 1 Remove the 4 screws of the Top Panel.

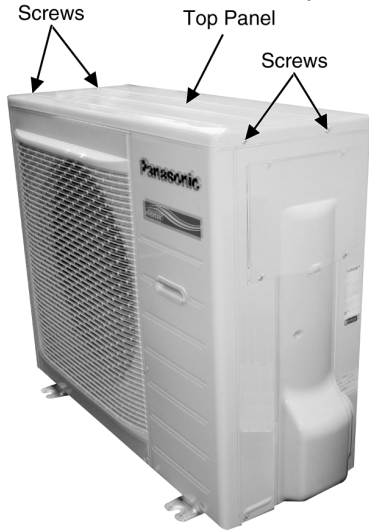

Fig. 1

- 2 Remove the 10 screws of the Front Panel.

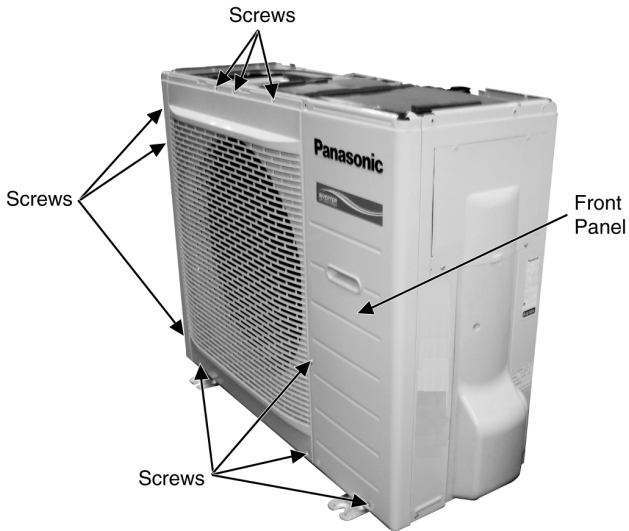

Fig. 2

- 3 Remove the Top Cover of the Electronic Controller.



Fig. 3

- 4 Remove the Control Board.

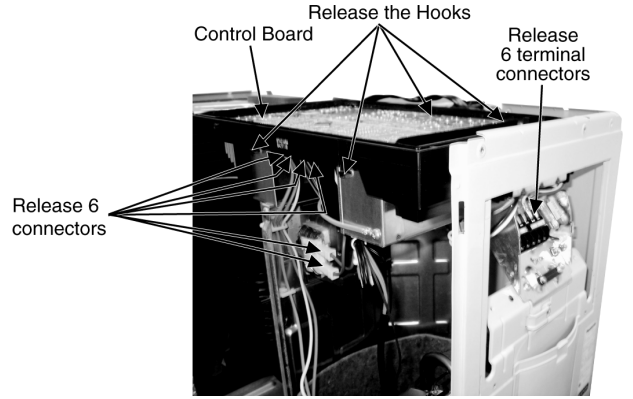

Fig. 4

- 5 Remove the 8 screws of the Electronic Controller.

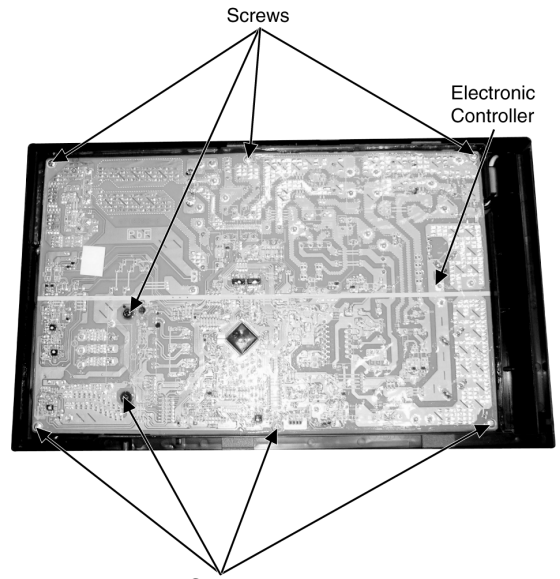

Fig. 5

⚠ Caution! When handling electronic controller, be careful of electrostatic discharge.

# 13. Technical Data

## 13.1 Operation Characteristics

### 13.1.1 CS-E9GFEW CU-E9PFE CS-E9GFEW-2 CU-E9PFE

- Cooling Characteristic
- [Condition] Indoor temperature: 27/19°C  
Piping Length: 5m  
Remote condition: High fan speed, Cool 16°C  
Comp. Hz: F<sub>c</sub>

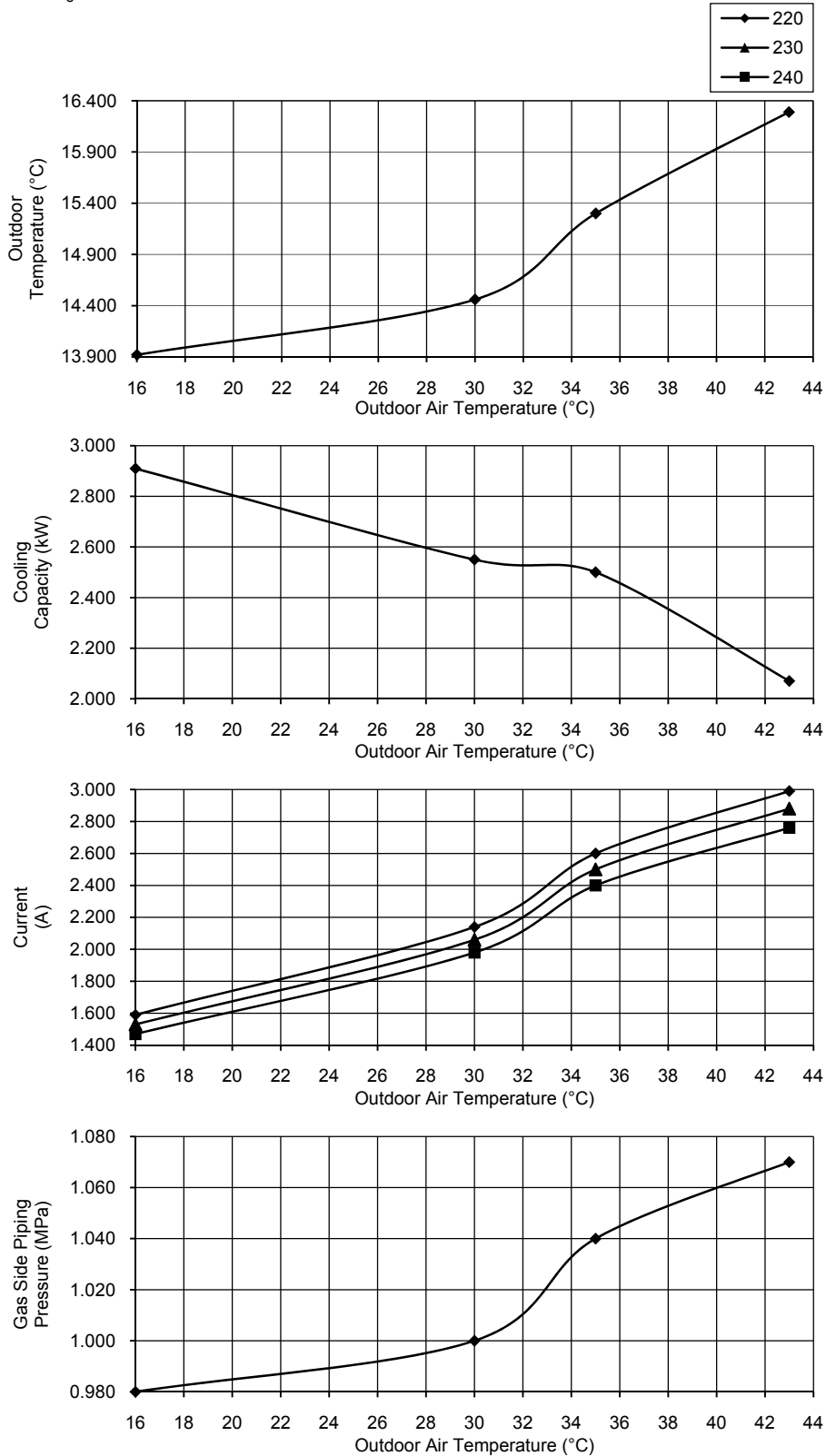

- Piping Length Characteristic

[Condition] Indoor temperature: 27/19°C, 35/-°C

Remote condition: High fan speed, Cool 16°C

Comp. Hz:  $F_c$

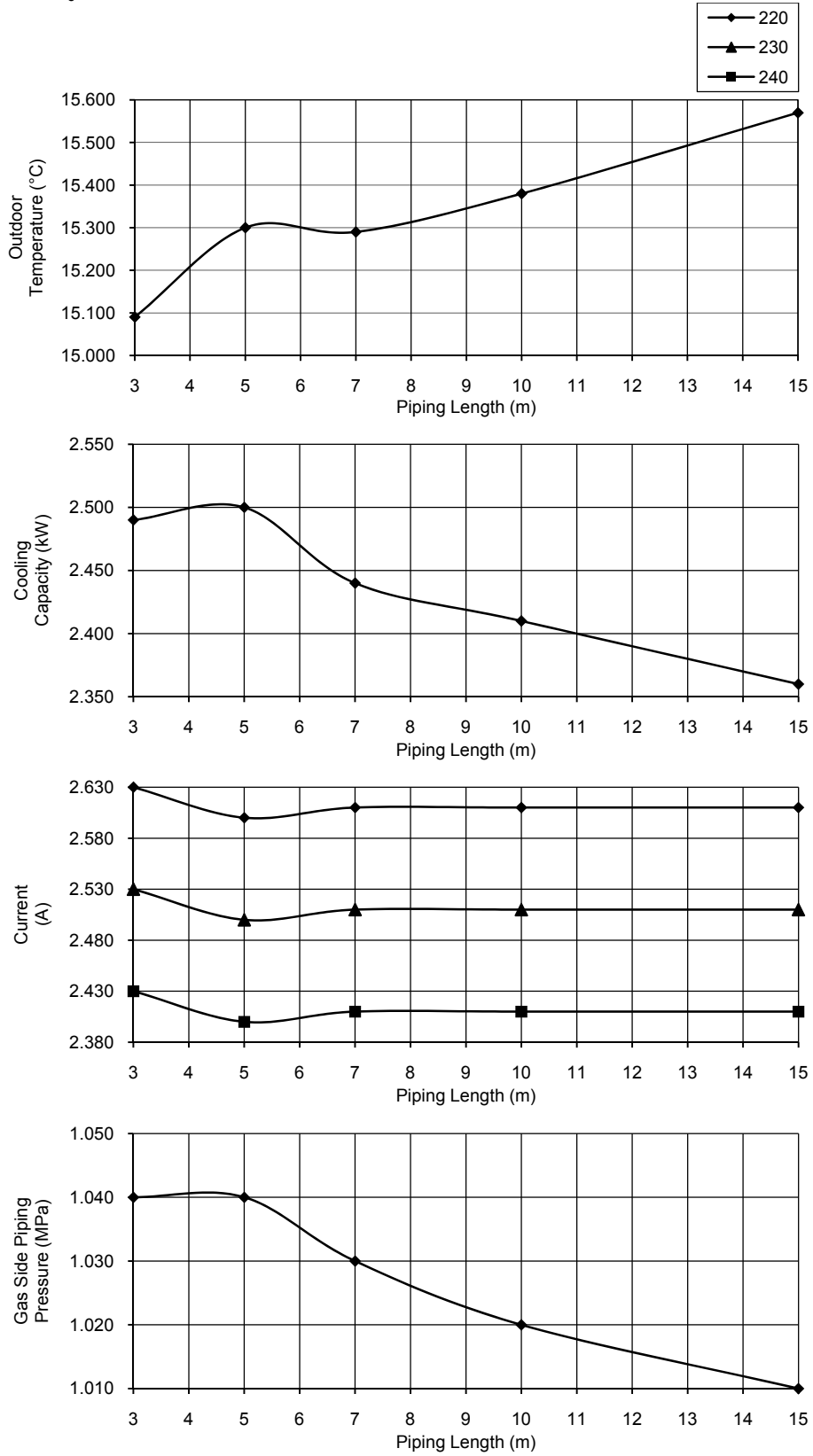

- Heating Characteristic
- [Condition] Indoor temperature: 20/-°C  
Piping Length: 5m  
Remote condition: High fan speed, Heat 30°C  
Comp. Hz: F<sub>h</sub>

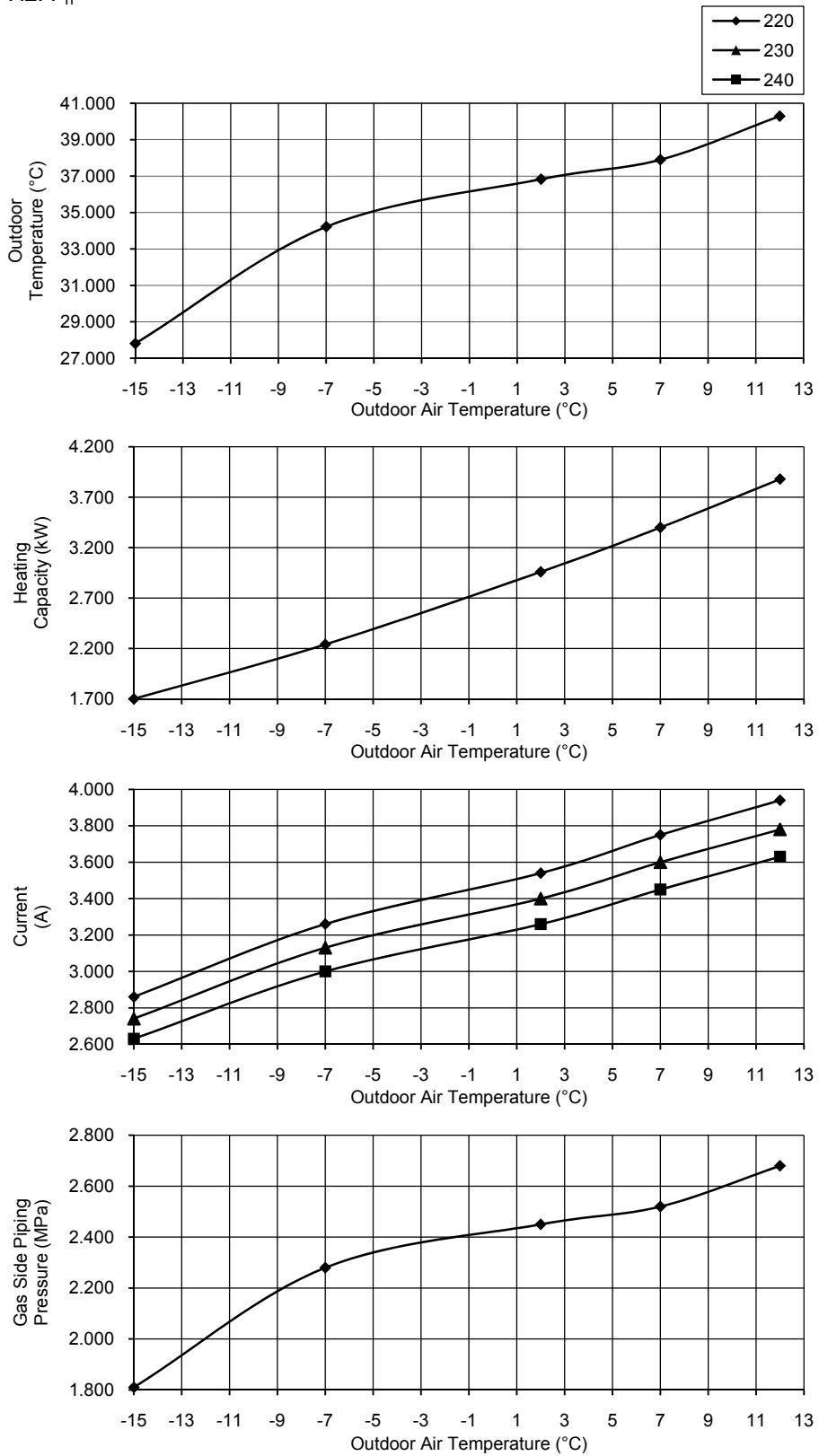

- Piping Length Characteristic

[Condition] Indoor temperature: 20/-°C, 7/6°C

Remote condition: High fan speed, Heat 30°C

Comp. Hz:  $F_h$

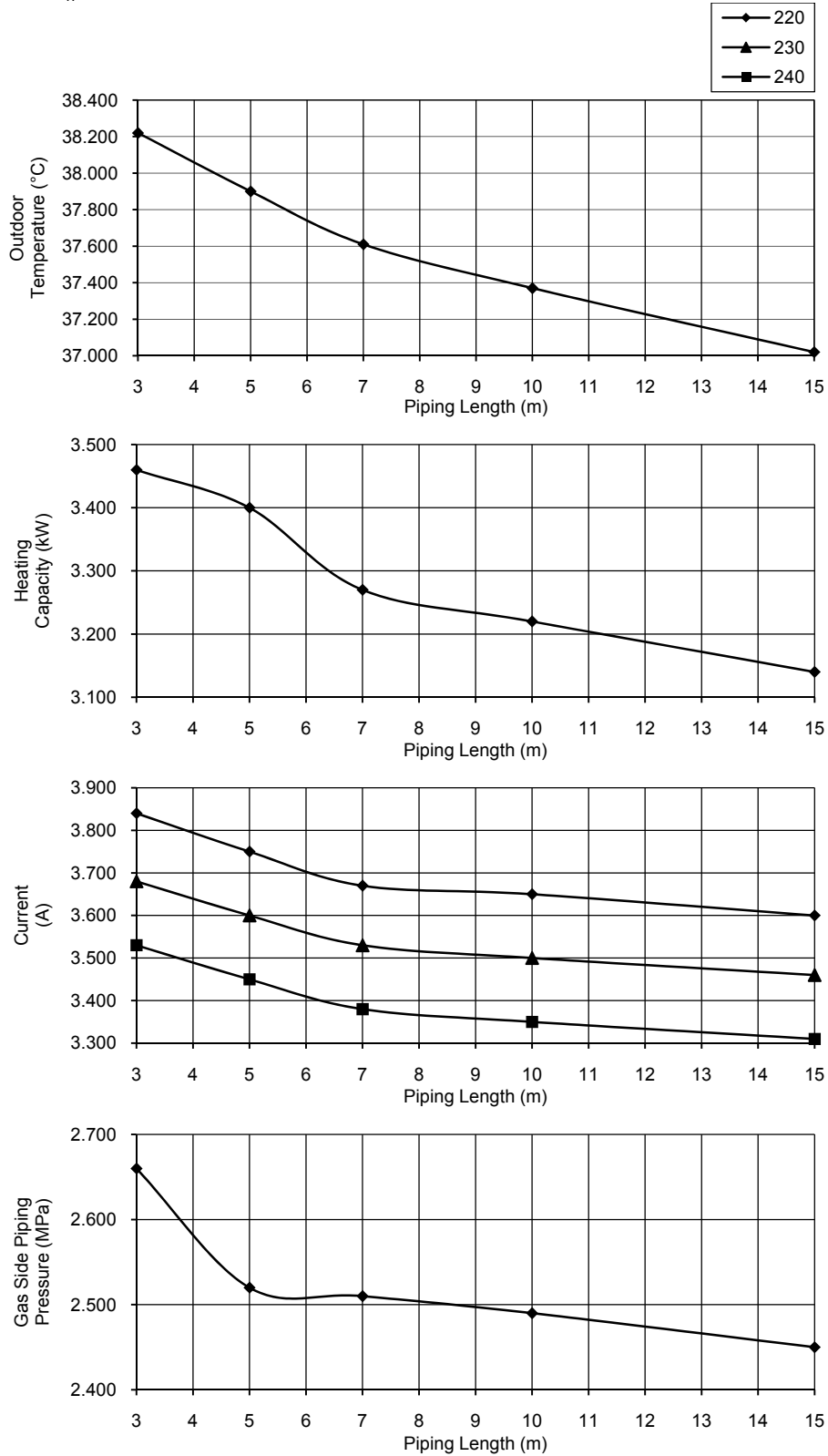

### 13.1.2 CS-E12GFEW CU-E12PFE CS-E12GFEW-2 CU-E12PFE

- Cooling Characteristic

[Condition] Indoor temperature: 27/19°C

Piping Length: 5m

Remote condition: High fan speed, Cool 16°C

Comp. Hz:  $F_c$

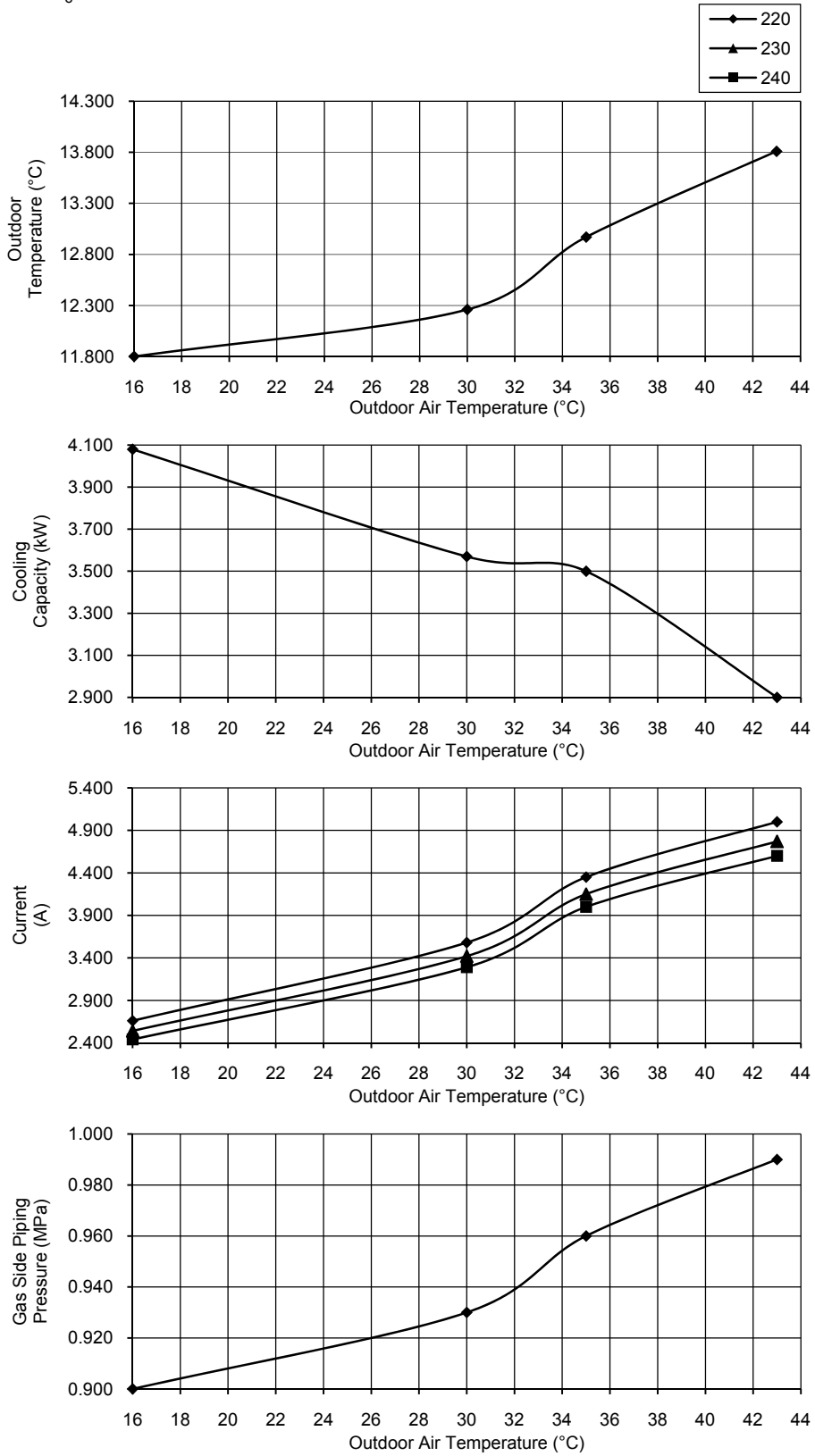

- Piping Length Characteristic

[Condition] Indoor temperature: 27/19°C, 35/-°C

Remote condition: High fan speed, Cool 16°C

Comp. Hz:  $F_c$

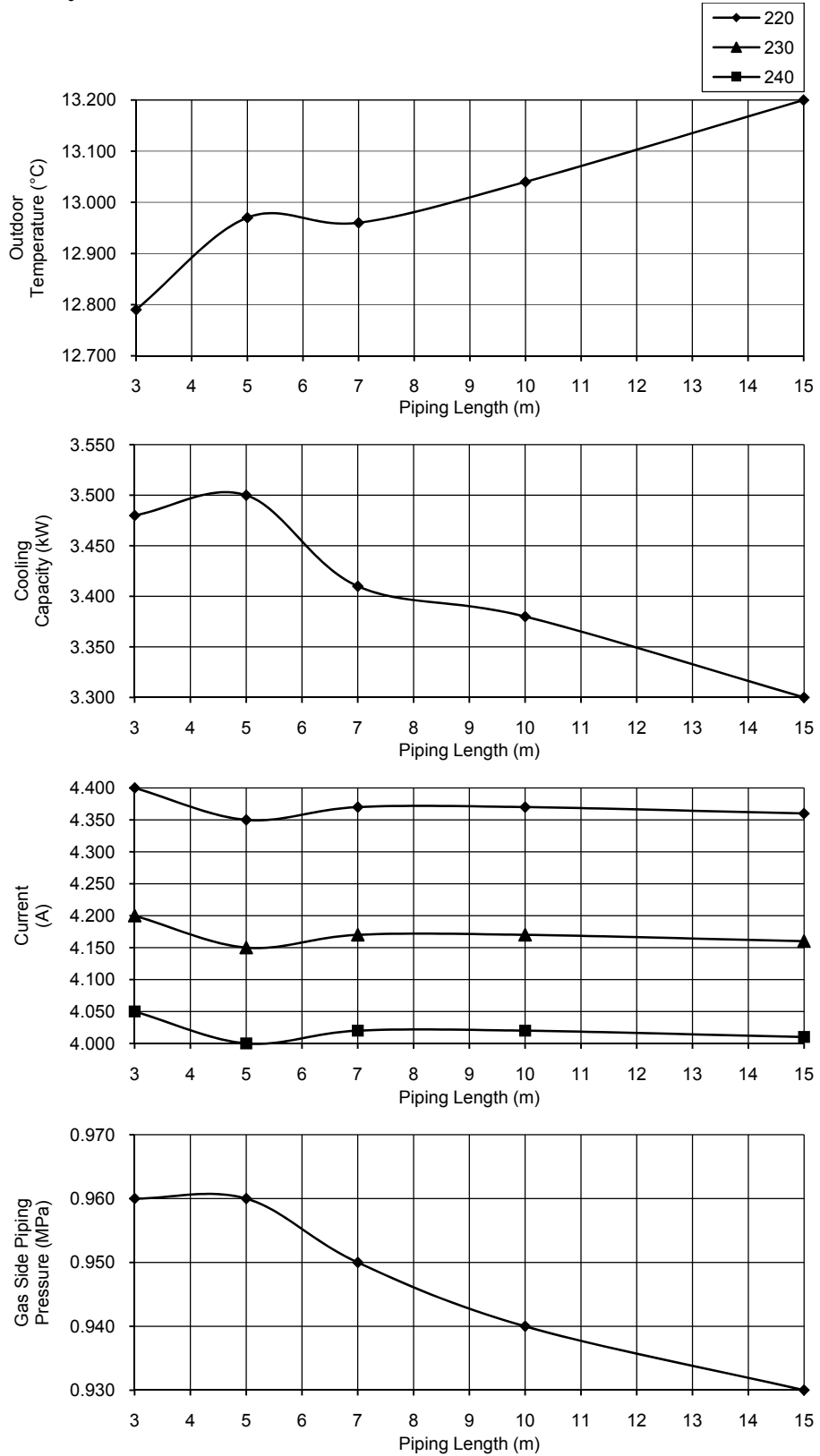



- Heating Characteristic
- [Condition] Indoor temperature: 20/-°C  
Piping Length: 5m  
Remote condition: High fan speed, Heat 30°C  
Comp. Hz: F<sub>h</sub>

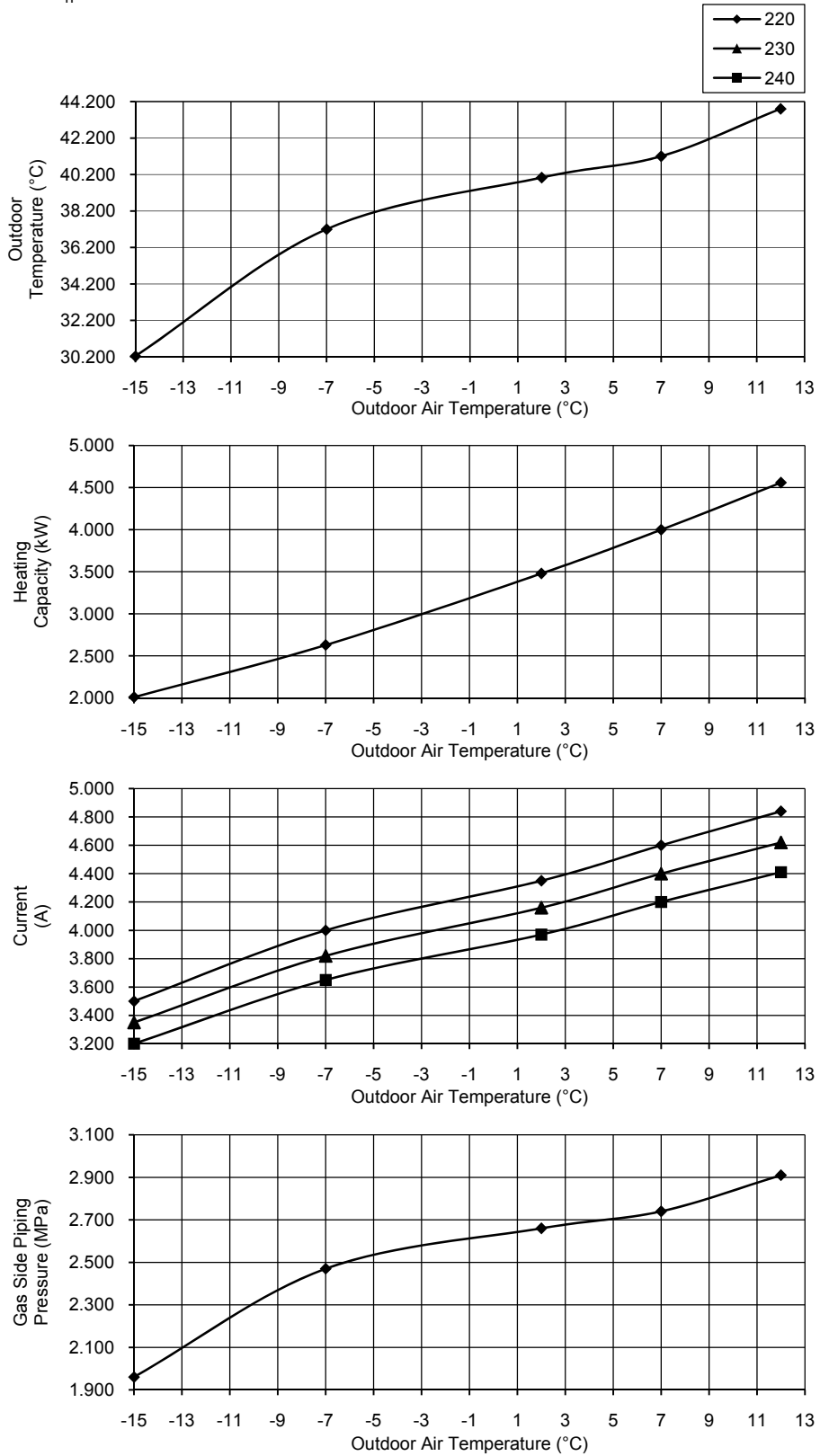

- Piping Length Characteristic

[Condition] Indoor temperature: 20/-°C, 7/6°C

Remote condition: High fan speed, Heat 30°C

Comp. Hz:  $F_h$

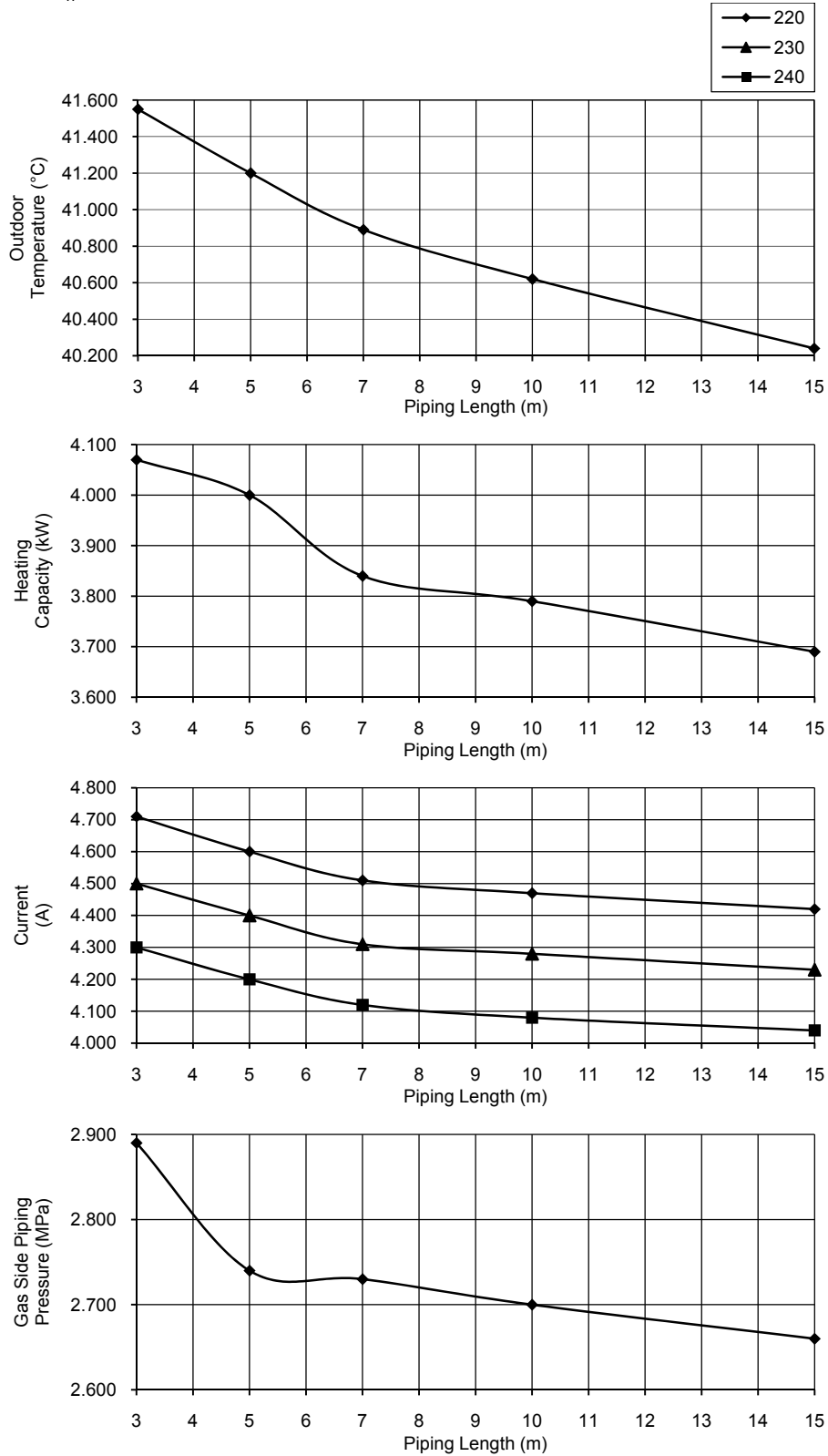

### 13.1.3 CS-E18GFEW CU-E18PFE

- Cooling Characteristic

[Condition] Indoor temperature: 27/19°C

Piping Length: 5m

Remote condition: High fan speed, Cool 16°C

Comp. Hz:  $F_c$

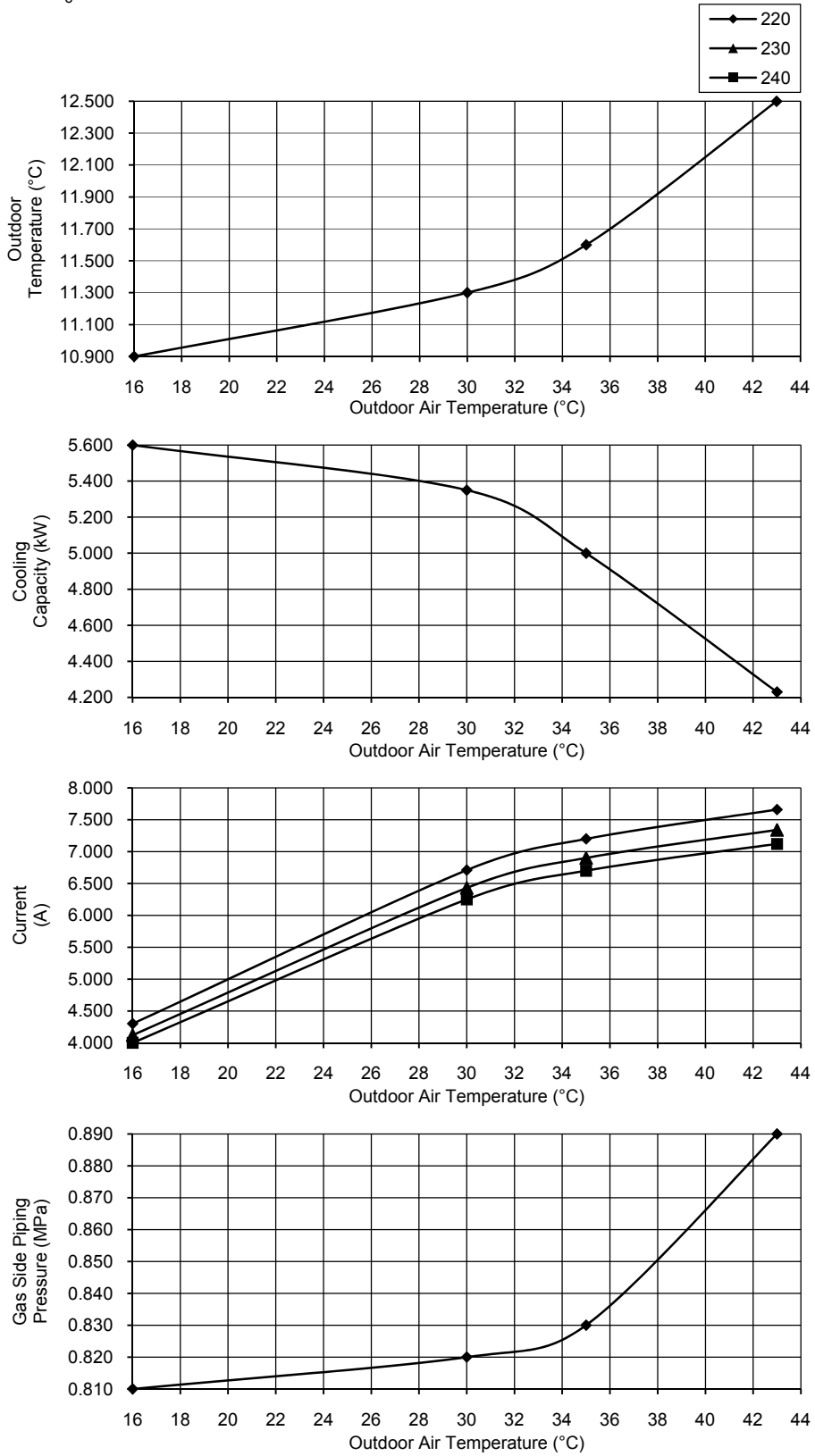

• Piping Length Characteristic

[Condition] Indoor temperature: 27/19°C, 35/-°C

Remote condition: High fan speed, Cool 16°C

Comp. Hz:  $F_c$

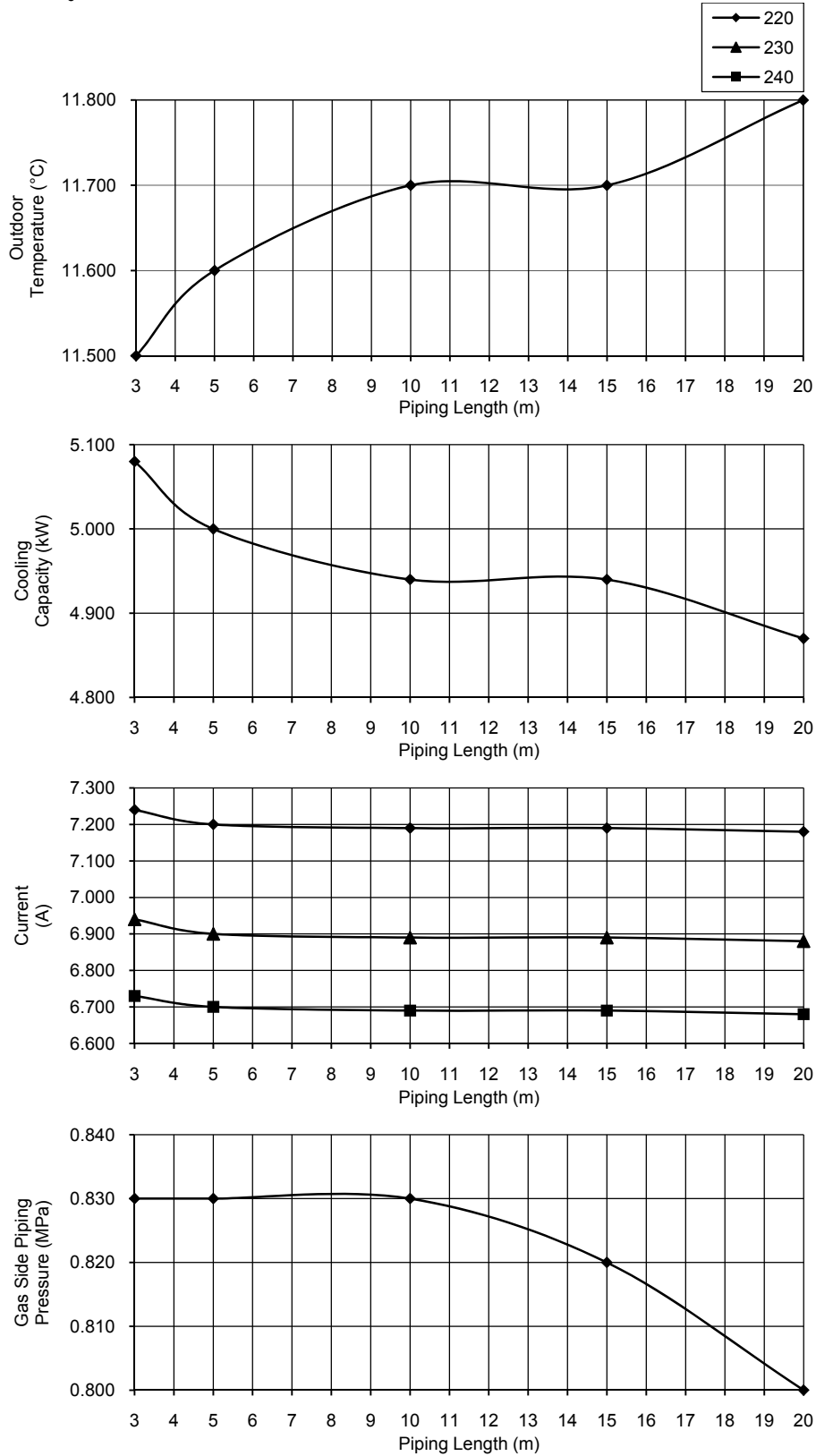

- Heating Characteristic
- [Condition] Indoor temperature: 20/-°C  
Piping Length: 5m  
Remote condition: High fan speed, Heat 30°C  
Comp. Hz: F<sub>h</sub>

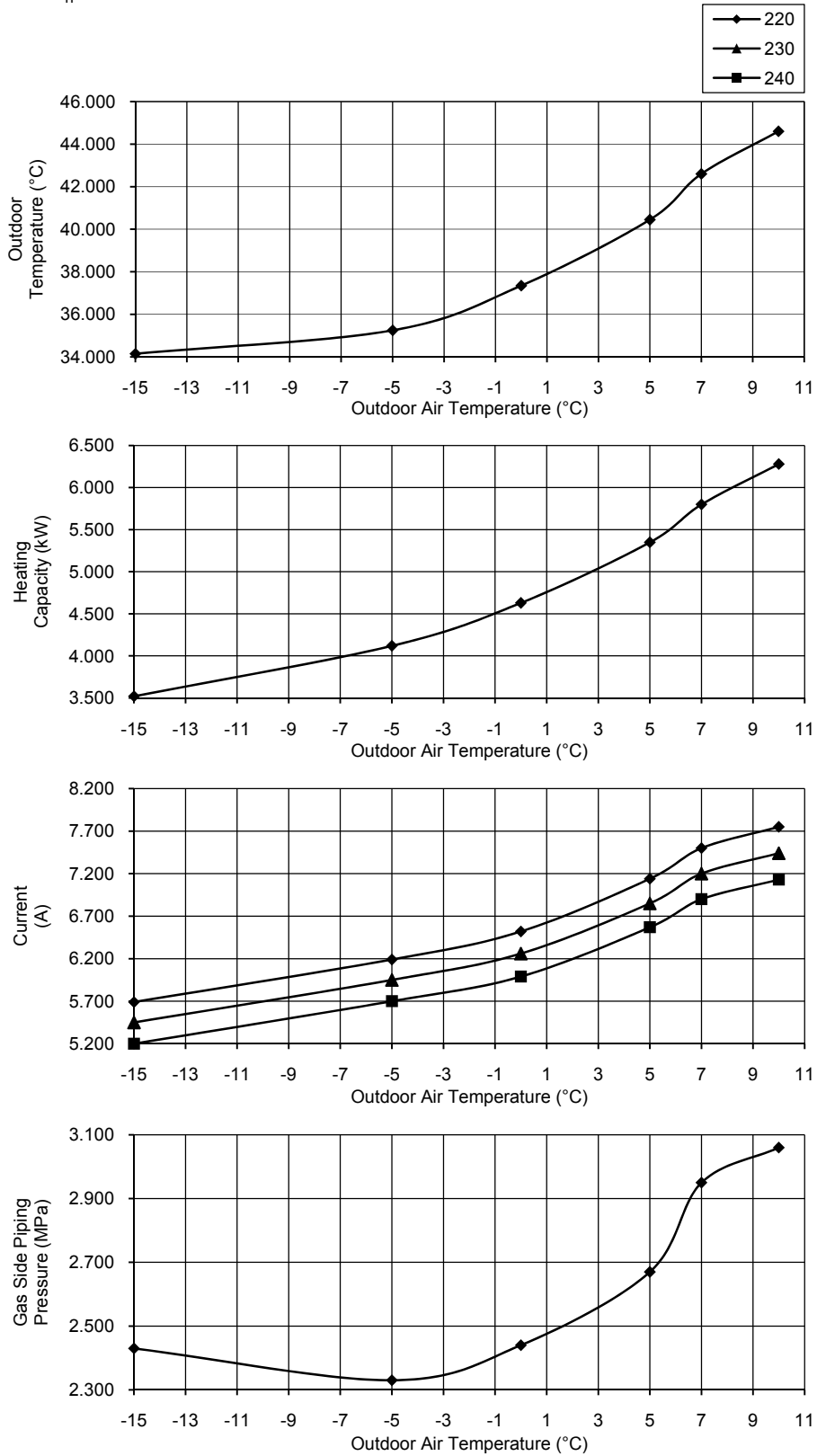

• Piping Length Characteristic

[Condition] Indoor temperature: 20/-°C, 7/6°C

Remote condition: High fan speed, Heat 30°C

Comp. Hz:  $F_h$

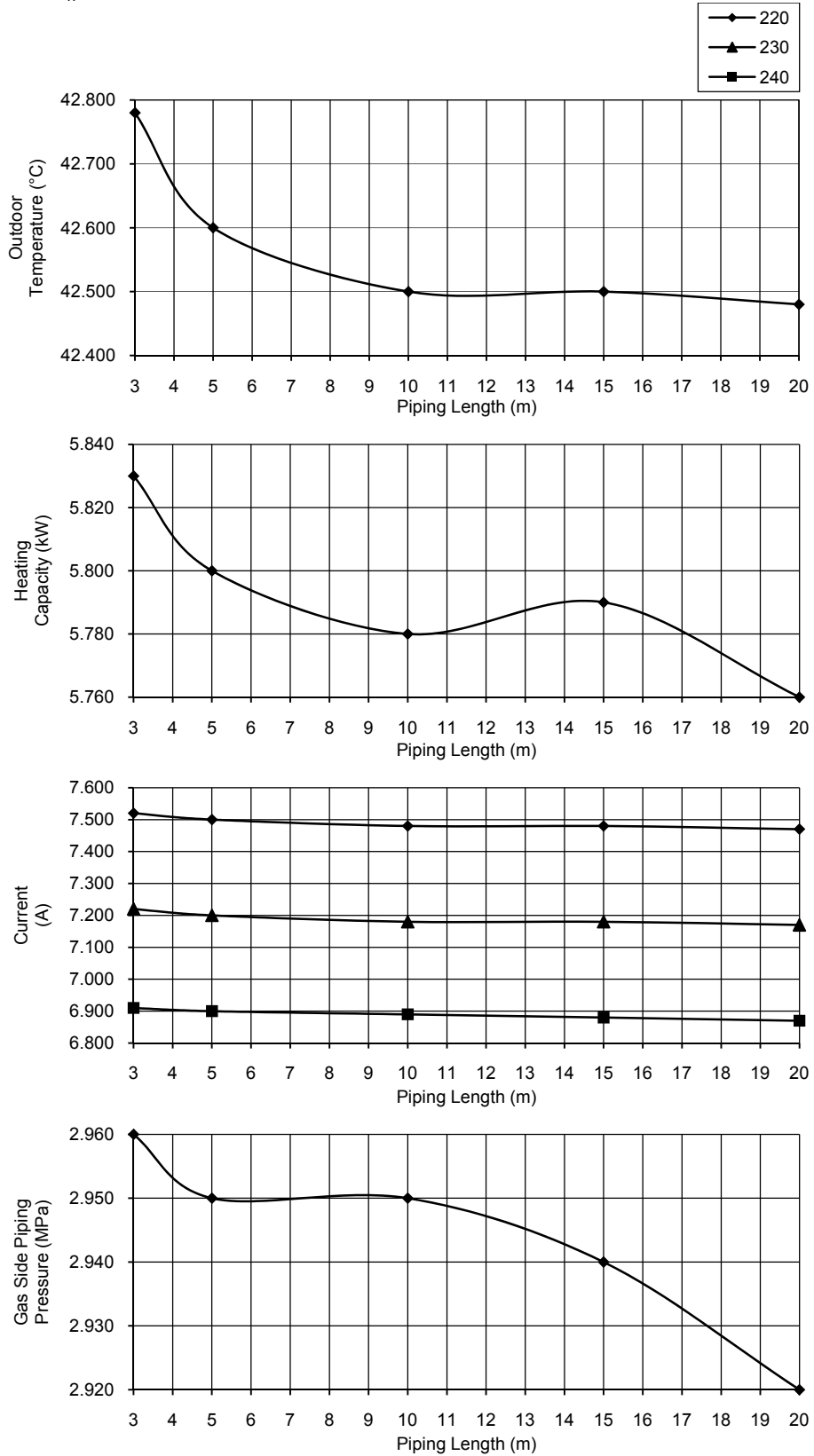

## 13.2 Sensible Capacity Chart

- CU-E9PFE

220/230/240V	Outdoor Temperature											
	30 °C			35 °C			40 °C			46 °C		
	Indoor wet bulb	TC	SHC	IP	TC	SHC	IP	TC	SHC	IP	TC	SHC
17.0 °C	2.48	1.88	0.51	2.32	1.80	0.55	2.16	1.73	0.58	1.96	1.65	0.63
19.0 °C				2.50		0.56						
19.5 °C	2.72	1.97	0.52	2.55	1.89	0.56	2.37	1.82	0.60	2.15	1.73	0.64
22.0 °C	2.97	2.04	0.53	2.77	1.96	0.57	2.58	1.89	0.61	2.35	1.81	0.65

- CU-E12PFE

220/230/240V	Outdoor Temperature											
	30 °C			35 °C			40 °C			46 °C		
	Indoor wet bulb	TC	SHC	IP	TC	SHC	IP	TC	SHC	IP	TC	SHC
17.0 °C	3.47	2.63	0.86	3.24	2.52	0.93	3.02	2.43	0.99	2.74	2.30	1.07
19.0 °C				3.50		0.94						
19.5 °C	3.81	2.76	0.88	3.56	2.65	0.94	3.31	2.55	1.01	3.01	2.43	1.09
22.0 °C	4.15	2.86	0.89	3.88	2.75	0.96	3.61	2.65	1.03	3.28	2.53	1.11

- CU-E18PFE

220/230/240V	Outdoor Temperature											
	30 °C			35 °C			40 °C			46 °C		
	Indoor wet bulb	TC	SHC	IP	TC	SHC	IP	TC	SHC	IP	TC	SHC
17.0 °C	4.96	3.76	1.41	4.64	3.61	1.52	4.31	3.47	1.62	3.92	3.29	1.75
19.0 °C				5.00		1.54						
19.5 °C	5.45	3.94	1.44	5.09	3.78	1.55	4.74	3.64	1.65	4.31	3.47	1.78
22.0 °C	5.94	4.08	1.46	5.55	3.93	1.57	5.16	3.79	1.68	4.69	3.61	1.82

TC - Total Cooling Capacity (kW)

SHC - Sensible Heat Capacity (kW)

IP - Input Power (kW)

Indoor 27°C/19°C

Outdoor 35°C/24°C





SAFETY	REF. NO.	PART NAME & DESCRIPTION	QTY.	CU-E9PFE	REMARK
	1	CHASSIS COMPLETE	1	CWD50K2073	
	2	SOUND PROOF MATERIAL	1	CWG302314	
	3	FAN MOTOR BRACKET	1	CWD541089	
	4	SCREW - FAN MOTOR BRACKET	2	CWH551217	
⚠	5	FAN MOTOR	1	ARS6411AC	O
	6	SCREW - FAN MOTOR MOUNT	4	CWH55252J	
	7	PROPELLER FAN ASSY	1	CWH03K1010	
	8	NUT - PROPELLER FAN	1	CWH56053J	
⚠	9	COMPRESSOR	1	5RS102XBC21	O
	10	ANTI - VIBRATION BUSHING	3	CWH50077	
	11	NUT - COMPRESSOR MOUNT	3	CWH56000J	
	12	CONDENSER	1	CWB32C3797	
	13	EXPANSION VALVE	1	CWB051055	
	14	DISCHARGE MUFFLER (4 W.VALVE)	1	CWB121010	
	15	HOLDER COUPLING	1	CWH351023	
	16	2-WAYS VALVE (LIQUID)	1	CWB021589	O
	17	3-WAY VALVE (GAS)	1	CWB011374	O
⚠	19	REACTOR	1	G0C103J00029	O
	20	TERMINAL COVER	1	CWH171039A	
	21	NUT - TERMINAL COVER	1	CWH7080300J	
	22	SOUND PROOF BOARD	1	CWH151172	
	23A	SOUND PROOF MATERIAL	1	CWG302315	
	23B	SOUND PROOF MATERIAL	1	CWG302316	
	23C	SOUND PROOF MATERIAL	1	CWG302317	
	24	SENSOR CO - COMP TEMP	1	CWA50C2205	O
	25	CONTROL BOARD COVER - TOP	1	CWH131264	
⚠	26	ELECTRONIC CONTROLLER - MAIN	1	CWA73C7759R	O
⚠	27	TERMINAL BOARD ASSY	1	CWA28K1110J	O
	28	CABINET SIDE PLATE CO.	1	CWE04C1116	
	29	SENSOR CO - AIR TEMP AND PIPE TEMP	1	CWA50C3080	O
	30	CABINET SIDE PLATE	1	CWE041248A	
	31	CABINET FRONT PLATE CO.	1	CWE06C1136	
	32	CABINET TOP PLATE	1	CWE031014A	
	33	PLATE - C. B. COVER TERMINAL	1	CWH131301	
	34	CONTROL BOARD COVER CO.	1	CWH13C1211	
	35	HANDLE	1	CWE161010	
	38	4-WAYS VALVE	1	CWB001037J	
⚠	39	V-COIL COMPLETE (4-WAY VALVE)	1	CWA43C2431	O
	40	WIRE NET	1	CWD041161A	O
⚠	41	V-COIL COMPLETE (EXP.VALVE)	1	CWA43C2257	
	42	DISCHARGE MUFFLER	1	CWB121021	
	43	STRAINER	1	CWB11094	
	51	BAG	1	CWG861078	
	52	BASE BOARD - COMPLETE	1	CWG62C1095	
	53	SHOCK ABSORBER (RIGHT)	1	CWG712969	
	54	SHOCK ABSORBER (LEFT)	1	CWG712970	
	55	C.C.CASE	1	CWG568356	
	56	L - TUBE	1	CWH5850080	
	57	PACKING - L. TUBE	1	CWB81012	
	58	HOLDER SENSOR	1	CWH32143	

SAFETY	REF. NO.	PART NAME & DESCRIPTION	QTY.	CU-E9PFE	REMARK
	59	OPERATING INSTRUCTION	1	CWF569015	
	60	INSTALLATION INSTRUCTION	1	CWF615933	
	61	INSTALLATION INSTRUCTION	1	CWF615934	
	62	INSTALLATION INSTRUCTION	1	CWF615935	
	63	INSTALLATION INSTRUCTION	1	CWF615936	
	64	INSTALLATION INSTRUCTION	1	CWF615937	
	65	INSTALLATION INSTRUCTION	1	CWF615938	
	66	INSTALLATION INSTRUCTION	1	CWF615939	
	67	INSTALLATION INSTRUCTION	1	CWF615940	
	68	INSTALLATION INSTRUCTION	1	CWF615941	
	69	INSTALLATION INSTRUCTION	1	CWF615942	
	70	INSTALLATION INSTRUCTION	1	CWF615943	
	71	INSTALLATION INSTRUCTION	1	CWF615944	
	72	INSTALLATION INSTRUCTION	1	CWF615945	

(NOTE)

- All parts are supplied from PAPAMY, Malaysia (Vendor Code: 00029488).
- "O" marked parts are recommended to be kept in stock.

## 14.1.2 CU-E12PFE

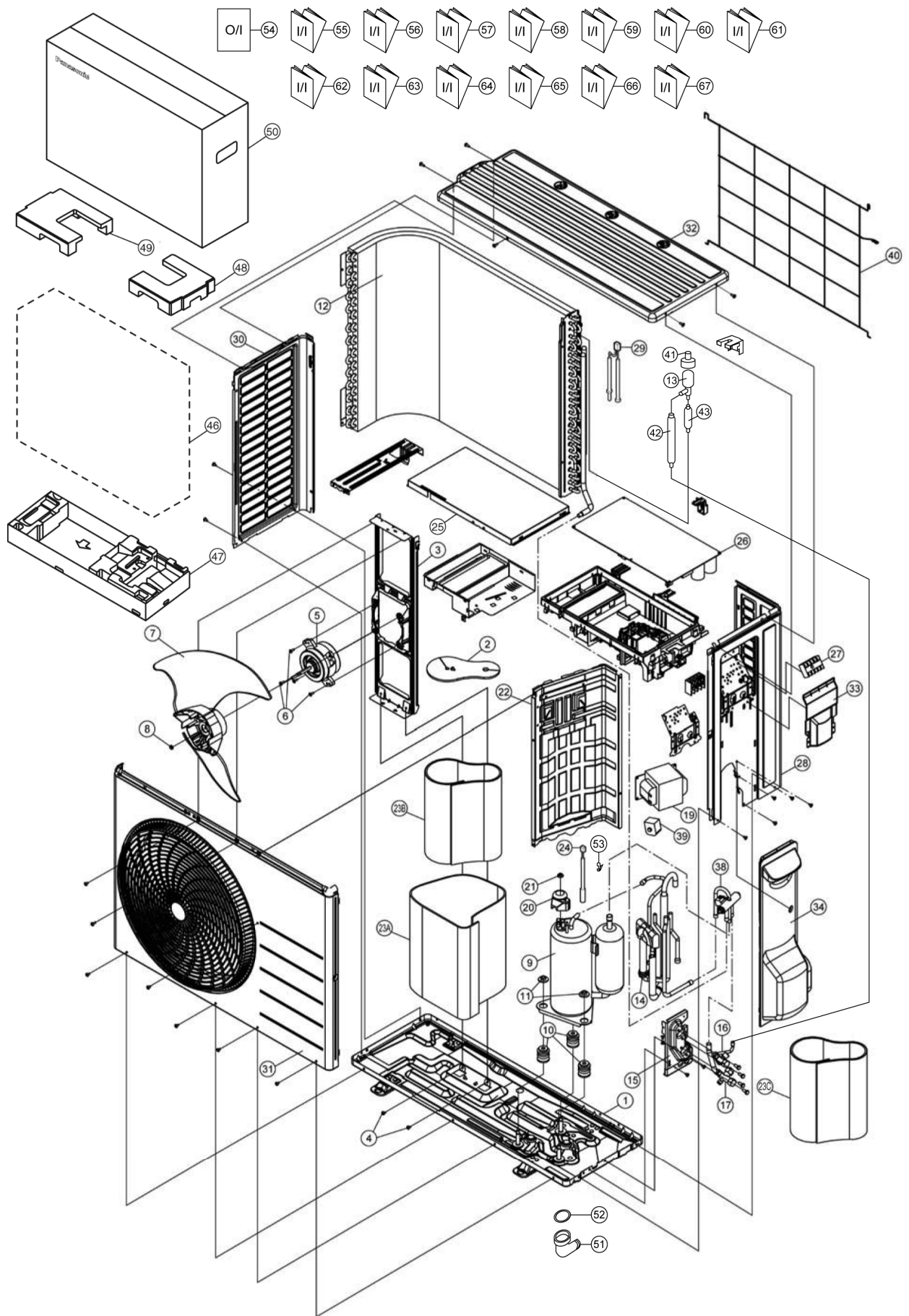

### Note

The above exploded view is for the purpose of parts disassembly and replacement. The non-numbered parts are not kept as standard service parts.

SAFETY	REF. NO.	PART NAME & DESCRIPTION	QTY.	CU-E12PFE	REMARK
	1	CHASSIS COMPLETE	1	CWD52K1277	
	2	SOUND PROOF MATERIAL	1	CWG302719	
	3	FAN MOTOR BRACKET	1	CWD541167	
	4	SCREW - FAN MOTOR BRACKET	2	CWH551217	
⚠	5	FAN MOTOR	1	ARS6411AC	O
	6	SCREW - FAN MOTOR MOUNT	4	CWH55252J	
	7	PROPELLER FAN ASSY	1	CWH03K1066	
	8	NUT - PROPELLER FAN	1	CWH56053J	
⚠	9	COMPRESSOR	1	5RS102XNA21	O
	10	ANTI - VIBRATION BUSHING	3	CWH50077	
	11	NUT - COMPRESSOR MOUNT	3	CWH56000J	
	12	CONDENSER	1	CWB32C3680	
	13	EXPANSION VALVE	1	CWB051055	
	14	DISCHARGE MUFFLER (4 W.VALVE)	1	CWB121010	
	15	HOLDER COUPLING	1	CWH351023	
	16	2-WAYS VALVE (LIQUID)	1	CWB021180J	O
	17	3-WAY VALVE (GAS)	1	CWB011374	O
⚠	19	REACTOR	1	G0C103J00029	O
	20	TERMINAL COVER	1	CWH171039A	
	21	NUT - TERMINAL COVER	1	CWH7080300J	
	22	SOUND PROOF BOARD	1	CWH151274	
	23A	SOUND PROOF MATERIAL	1	CWG302317	
	23B	SOUND PROOF MATERIAL	1	CWG302701	
	23C	SOUND PROOF MATERIAL	1	CWG302726	
	24	SENSOR CO - COMP TEMP	1	CWA50C2894	O
	25	CONTROL BOARD COVER - TOP	1	CWH131473	
⚠	26	ELECTRONIC CONTROLLER - MAIN	1	CWA73C7760R	O
⚠	27	TERMINAL BOARD ASSY	1	CWA28K1110J	O
	28	CABINET SIDE PLATE CO.	1	CWE04C1296	
	29	SENSOR CO - AIR TEMP AND PIPE TEMP	1	CWA50C3078	
	30	CABINET SIDE PLATE	1	CWE041580A	
	31	CABINET FRONT PLATE CO.	1	CWE06C1360	
	32	CABINET TOP PLATE	1	CWE031148A	
	33	PLATE - C. B. COVER TERMINAL	1	CWH131470A	
	34	CONTROL BOARD COVER CO.	1	CWH13C1253	
	38	4-WAYS VALVE	1	CWB001037J	O
⚠	39	V-COIL COMPLETE (4-WAY VALVE)	1	CWA43C2447	O
	40	WIRE NET	1	CWD041200A	
⚠	41	V-COIL COMPLETE (EXP.VALVE)	1	CWA43C2257	
	42	DISCHARGE MUFFLER	1	CWB121021	
	43	STRAINER	1	CWB11094	
	46	BAG	1	CWG861078	
	47	BASE BOARD - COMPLETE	1	CWG62C1144	
	48	SHOCK ABSORBER (RIGHT)	1	CWG713415	
	49	SHOCK ABSORBER (LEFT)	1	CWG713416	
	50	C.C.CASE	1	CWG568358	
	51	L - TUBE	1	CWH5850080	
	52	PACKING - L. TUBE	1	CWB81012	
	53	HOLDER SENSOR	1	CWH32143	
	54	OPERATING INSTRUCTION	1	CWF569015	

SAFETY	REF. NO.	PART NAME & DESCRIPTION	QTY.	CU-E12PFE	REMARK
	55	INSTALLATION INSTRUCTION	1	CWF615933	
	56	INSTALLATION INSTRUCTION	1	CWF615934	
	57	INSTALLATION INSTRUCTION	1	CWF615935	
	58	INSTALLATION INSTRUCTION	1	CWF615936	
	59	INSTALLATION INSTRUCTION	1	CWF615937	
	60	INSTALLATION INSTRUCTION	1	CWF615938	
	61	INSTALLATION INSTRUCTION	1	CWF615939	
	62	INSTALLATION INSTRUCTION	1	CWF615940	
	63	INSTALLATION INSTRUCTION	1	CWF615941	
	64	INSTALLATION INSTRUCTION	1	CWF615942	
	65	INSTALLATION INSTRUCTION	1	CWF615943	
	66	INSTALLATION INSTRUCTION	1	CWF615944	
	67	INSTALLATION INSTRUCTION	1	CWF615945	

(NOTE)

- All parts are supplied from PAPAMY, Malaysia (Vendor Code: 00029488).
- "O" marked parts are recommended to be kept in stock.

### 14.1.3 CU-E18PFE

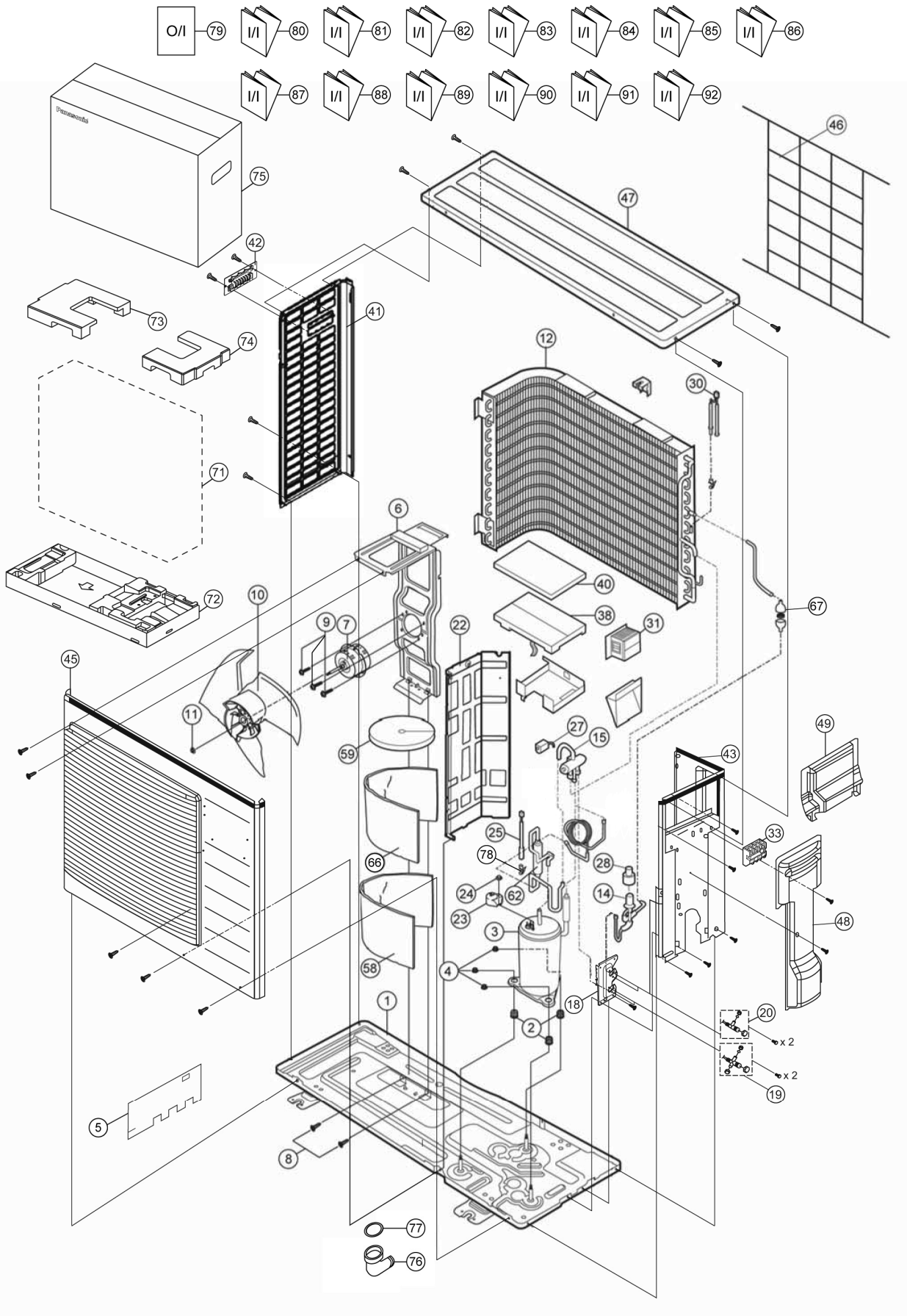

**Note**  
 The above exploded view is for the purpose of parts disassembly and replacement.  
 The non-numbered parts are not kept as standard service parts.

SAFETY	REF. NO.	PART NAME & DESCRIPTION	QTY.	CU-E18PFE	REMARK
	1	CHASSIS COMPLETE	1	CWD52K1261	
	2	ANTI - VIBRATION BUSHING	3	CWH50077	
⚠	3	COMPRESSOR	1	5RD132XBA21	O
	4	NUT - COMPRESSOR MOUNT	3	CWH56000J	
	5	SOUND PROOF MATERIAL	1	CWG302744	
	6	FAN MOTOR BRACKET	1	CWD541153	
⚠	7	FAN MOTOR	1	ARW8401AC	O
	8	SCREW - FAN MOTOR BRACKET	2	CWH551217	
	9	SCREW - FAN MOTOR MOUNT	4	CWH551106J	
	10	PROPELLER FAN ASSY	1	CWH03K1065	
	11	NUT - PROPELLER FAN	1	CWH56053J	
	12	CONDENSER	1	CWB32C3369	
	14	EXPANSION VALVE	1	CWB051016J	
	15	4-WAYS VALVE	1	CWB001026J	
	18	HOLDER COUPLING	1	CWH351227	
	19	3-WAY VALVE (GAS)	1	CWB011338	O
	20	2-WAYS VALVE (LIQUID)	1	CWB021454	O
	22	SOUND PROOF BOARD	1	CWH151257	
	23	TERMINAL COVER	1	CWH171039A	
	24	NUT - TERMINAL COVER	1	CWH7080300J	
	25	SENSOR COMPLETE	1	CWA50C2185	O
⚠	27	V-COIL COMPLETE (4-WAY VALVE)	1	CWA43C2169J	O
⚠	28	V-COIL COMPLETE (EXP.VALVE)	1	CWA43C2257	O
	30	SENSOR - COMPLETE (AIR TEMP AND PIPE TEMP)	1	CWA50C2517	O
⚠	31	REACTOR	1	G0C203J00003	O
⚠	33	TERMINAL BOARD ASSY	1	CWA28K1110J	O
⚠	38	ELECTRONIC CONTROLLER - MAIN	1	CWA73C7761R	O
	40	CONTROL BOARD COVER - TOP	1	CWH131333	
	41	CABINET SIDE PLATE (LEFT)	1	CWE041520A	
	42	HANDLE	1	CWE161010	
	43	CABINET SIDE PLATE (RIGHT)	1	CWE041555A	
	45	CABINET FRONT PLATE CO.	1	CWE06K1077	
	46	WIRE NET	1	CWD041155A	
	47	CABINET TOP PLATE	1	CWE031083A	
	48	CONTROL BOARD COVER - COMPLETE	1	CWH13C1238	
	49	CONTROL BOARD COVER	1	CWH131409A	
	58	SOUND PROOF MATERIAL	1	CWG302636	
	59	SOUND PROOF MATERIAL	1	CWG302630	
	62	RECEIVER	1	CWB14011	
	66	SOUND PROOF MATERIAL	1	CWG302632	
	67	STRAINER	1	CWB11094	
	71	BAG	1	CWG861461	
	72	BASE BOARD - COMPLETE	1	CWG62C1131	
	73	SHOCK ABSORBER (LEFT)	1	CWG713217	
	74	SHOCK ABSORBER (RIGHT)	1	CWG713218	
	75	C.C.CASE	1	CWG568359	
	76	L - TUBE	1	CWH5850080	
	77	PACKING - L. TUBE	1	CWB81012	
	78	HOLDER SENSOR	1	CWH32143	
	79	OPERATING INSTRUCTION	1	CWF569015	

SAFETY	REF. NO.	PART NAME & DESCRIPTION	QTY.	CU-E18PFE	REMARK
	80	INSTALLATION INSTRUCTION	1	CWF615933	
	81	INSTALLATION INSTRUCTION	1	CWF615934	
	82	INSTALLATION INSTRUCTION	1	CWF615935	
	83	INSTALLATION INSTRUCTION	1	CWF615936	
	84	INSTALLATION INSTRUCTION	1	CWF615937	
	85	INSTALLATION INSTRUCTION	1	CWF615938	
	86	INSTALLATION INSTRUCTION	1	CWF615939	
	87	INSTALLATION INSTRUCTION	1	CWF615940	
	88	INSTALLATION INSTRUCTION	1	CWF615941	
	89	INSTALLATION INSTRUCTION	1	CWF615942	
	90	INSTALLATION INSTRUCTION	1	CWF615943	
	91	INSTALLATION INSTRUCTION	1	CWF615944	
	92	INSTALLATION INSTRUCTION	1	CWF615945	

(NOTE)

- All parts are supplied from PAPAMY, Malaysia (Vendor Code: 00029488).
- "O" marked parts are recommended to be kept in stock.