

# Air conditioner

---

## Installation manual

AJ100MCJ5EH

---

- Thank you for purchasing this Samsung air conditioner.
- Before operating this unit, please read this manual carefully and retain it for future reference.



**SAMSUNG**

# Contents

---

<b>Safety Information</b>	<b>3</b>
General information	3
Installing the unit	4
Power supply line, fuse or circuit breaker	4
<b>Installation Procedure</b>	<b>5</b>
Step 1 Choosing the installation location	5
Step 2 Checking and preparing accessories and tools	7
Step 3 Fixing the outdoor unit in place	7
Step 4 Connecting the power cables, communication cable, and controllers	8
Step 5 Optional: Extending the power cable	13
Step 6 Connecting the refrigerant pipe	15
Step 7 Optional: Cutting and flaring the pipes	15
Step 8 Connecting up and removing air in the circuit	16
Step 9 Performing the gas leak test	17
Step 10 Adding refrigerant (R-410A)	18
Step 11 Connecting the drain hose to the outdoor unit	19
Step 12 Checking the earthing	19
Step 13 Setting an indoor unit address and installation option	20
Step 14 Cool and Heat modes operation test	27
<b>Extra procedures</b>	<b>28</b>
Pumping down refrigerant	28
Relocating the indoor and outdoor units	28
Using the stop valve	29
<b>Appendix</b>	<b>30</b>
Troubleshooting	30

For information on Samsung's environmental commitments and product specific regulatory obligations e.g. REACH visit: [samsung.com/uk/aboutsamsung/samsungelectronics/corporatecitizenship/data\\_corner.html](https://samsung.com/uk/aboutsamsung/samsungelectronics/corporatecitizenship/data_corner.html)

# Safety Information

---

## WARNING

- Hazards or unsafe practices that may result in severe personal injury or death.

## CAUTION

- Hazards or unsafe practices that may result in minor personal injury or property damage.

Carefully follow the precautions listed below because they are essential to guarantee the safety of the equipment.

## WARNING

- Always disconnect the air conditioner from the power supply before servicing it or accessing its internal components.
- Verify that installation and testing operations are performed by qualified personnel.
- Verify that the air conditioner is not installed in an easily accessible area.

## General information

---

## WARNING

- Carefully read the content of this manual before installing the air conditioner and store the manual in a safe place in order to be able to use it as reference after installation.
- For maximum safety, installers should always carefully read the following warnings.
- Store the operation and installation manual in a safe location and remember to hand it over to the new owner if the air conditioner is sold or transferred.
- This manual explains how to install an indoor unit with a split system with two SAMSUNG units. The use of other types of units with different control systems may damage the units and invalidate the warranty. The manufacturer shall not be responsible for damages arising from the use of non compliant units.
- The manufacturer shall not be responsible for damage originating from unauthorized changes or the improper connection of electric and requirements set forth in the "Operating limits" table, included in the manual, shall immediately invalidate the warranty.

- The air conditioner should be used only for the applications for which it has been designed: the indoor unit is not suitable to be installed in areas used for laundry.
- Do not use the units if damaged. If problems occur, switch the unit off and disconnect it from the power supply.
- In order to prevent electric shocks, fires or injuries, always stop the unit, disable the protection switch and contact SAMSUNG's technical support if the unit produces smoke, if the power cable is hot or damaged or if the unit is very noisy.
- Always remember to inspect the unit, electric connections, refrigerant tubes and protections regularly. These operations should be performed by qualified personnel only.
- The unit contains moving parts, which should always be kept out of the reach of children.
- Do not attempt to repair, move, alter or reinstall the unit. If performed by unauthorized personnel, these operations may cause electric shocks or fires.
- Do not place containers with liquids or other objects on the unit.
- All the materials used for the manufacture and packaging of the air conditioner are recyclable.
- The packing material and exhaust batteries of the remote controller(optional) must be disposed of in accordance with current laws.
- The air conditioner contains a refrigerant that has to be disposed of as special waste. At the end of its life cycle, the air conditioner must be disposed of in authorized centres or returned to the retailer so that it can be disposed of correctly and safely.
- This appliance is not intended for use by persons (including children) with reduced physical, sensory or mental capabilities, or lack of experience and knowledge, unless they have been given supervision or instruction concerning use of the appliance by a person responsible for their safety. Children should be supervised to ensure that they do not play with the appliance.

# Safety Information

- **For use in Europe:** This appliance can be used by children aged from 8 years and above and persons with reduced physical, sensory or mental capabilities or lack of experience and knowledge if they have been given supervision or instruction concerning use of the appliance in a safe way and understand the hazards involved. Children shall not play with the appliance. Cleaning and user maintenance shall not be made by children without supervision.

## Installing the unit

### **WARNING**

**IMPORTANT:** When installing the unit, always remember to connect first the refrigerant tubes, then the electrical lines.

- Upon receipt, inspect the product to verify that it has not been damaged during transport. If the product appears damaged, DO NOT INSTALL it and immediately report the damage to the carrier or retailer (if the installer or the authorized technician has collected the material from the retailer.)
- After completing the installation, always carry out a functional test and provide the instructions on how to operate the air conditioner to the user.
- Do not use the air conditioner in environments with hazardous substances or close to equipment that release free flames to avoid the occurrence of fires, explosions or injuries.
- Our units should be installed in compliance with the spaces shown in the installation manual, to ensure accessibility from both sides and allow repairs or maintenance operations to be carried out. The unit's components should be accessible and easy to disassemble without endangering people and objects.
- For this reason, when provisions of the installation manual are not complied with, the cost required to access and repair the units (in SAFETY CONDITIONS, as set out in prevailing regulations) with harnesses, ladders, scaffolding or any other elevation system will NOT be considered part of the warranty and will be charged to the end customer.

## Power supply line, fuse or circuit breaker

### **WARNING**

- Always make sure that the power supply is compliant with current safety standards. Always install the air conditioner in compliance with current local safety standards.
- Always verify that a suitable earthing connection is available.
- Verify that the voltage and frequency of the power supply comply with the specifications and that the installed power is sufficient to ensure the operation of any other domestic appliance connected to the same electric lines.
- Always verify that the cut-off and protection switches are suitably dimensioned.
- Verify that the air conditioner is connected to the power supply in accordance with the instructions provided in the wiring diagram included in the manual.
- Always verify that electric connections (cable entry, section of leads, protections...) are compliant with the electric specifications and with the instructions provided in the wiring scheme. Always verify that all connections comply with the standards applicable to the installation of air conditioners.
- Devices disconnected from the power supply should be completely disconnected in the condition of overvoltage category.
- Be sure not to perform power cable modification, extension wiring, and multiple wire connection.
  - It may cause electric shock or fire due to poor connection, poor insulation, or current limit override.
  - When extension wiring is required due to power line damage, refer to "Step 5 Optional: Extending the power cable" in the installation manual.

# Installation Procedure

## Step 1 Choosing the installation location

### Installation location requirements

- Do not place the outdoor unit on its side or upside down. Failing to do so may cause the compressor lubrication oil to run into the cooling circuit and lead to a serious damage to the unit.
- Install the unit in a well-ventilated location away from direct sunlight or strong winds.
- Install the unit in a location that would not obstruct any passageways or thoroughfares.
- Install the unit in a location that would not inconvenience or disturb your neighbors, as they could be affected by the noise or the airflow coming from the unit.
- Install the unit in a location where the pipes and the cables can be easily connected to the indoor unit.
- Install the unit on a flat, stable surface that can withstand the weight of the unit. Otherwise, the unit can generate noise and vibration during operation.
- Install the unit so that the air flow is directed towards the open area.
- Maintain sufficient clearance around the outdoor unit, especially from a radio, computer, stereo system, etc.

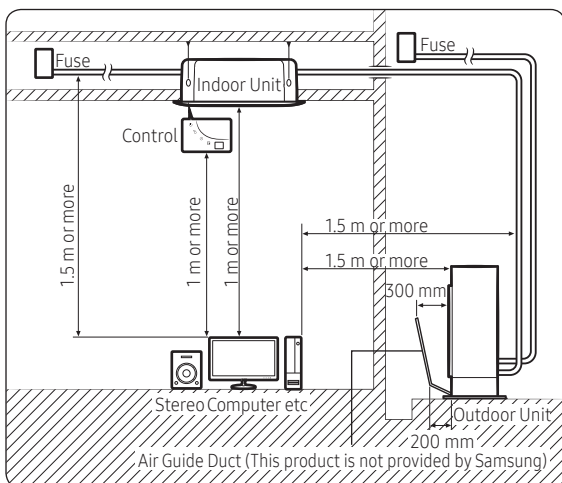

- Install the unit at a height where its base can be firmly fixed in place.
- Make sure that the water dripping from the drain hose runs away correctly and safely.

### ⚠ CAUTION

- You have just purchased a system air conditioner and it has been installed by your installation specialist.
- This device must be installed according to the national electrical rules.
- If your outdoor unit exceeds a net weight of 60 kg, do not install it on a suspended wall, but stand it on a floor.
- When installing the outdoor unit at the seaside, make sure that it is not directly exposed to sea breeze. If you cannot find an adequate place free from direct sea breeze, construct a protection wall or a protective fence.
  - Install the outdoor unit in a place (such as near buildings etc.) where it can be prevented from sea breeze. Failure to do so may cause a damage to the outdoor unit.

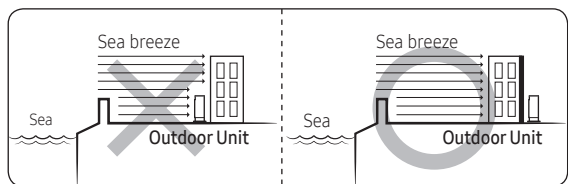

- If you cannot avoid installing the outdoor unit at the seaside, construct a protection wall around to block the sea breeze.
- Construct a protection wall with a solid material such as concrete to block the sea breeze. Make sure that the height and the width of the wall are 1.5 times larger than the size of the outdoor unit. Also, secure a space larger than 700 mm between the protection wall and the outdoor unit for exhausted air to ventilate.

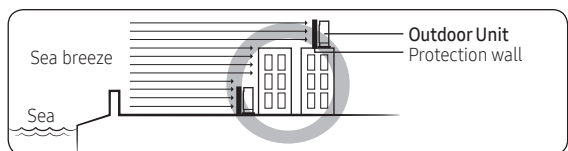

### ⚠ CAUTION

- Depending on the condition of power supply, unstable power or voltage may cause malfunction of the parts or control system. (At the ship or places using power supply from electric generator...etc)

# Installation Procedure

- Install the unit in a place where water can drain smoothly.
- If you have any difficulty finding installation location as prescribed above, contact your manufacturer for details.
- Be sure to clean the sea water and the dust on the heat exchanger of the outdoor unit and apply a corrosion inhibitor on it. (At least once in a year.)

## Minimum clearances for the outdoor unit

### When installing 1 outdoor unit

(Unit: mm)

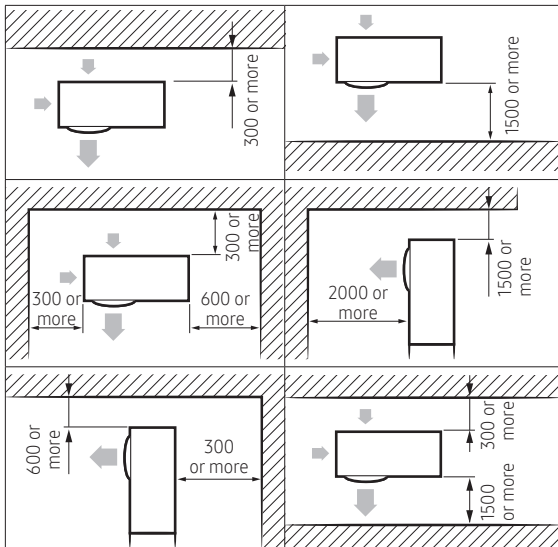

### When installing more than 1 outdoor unit



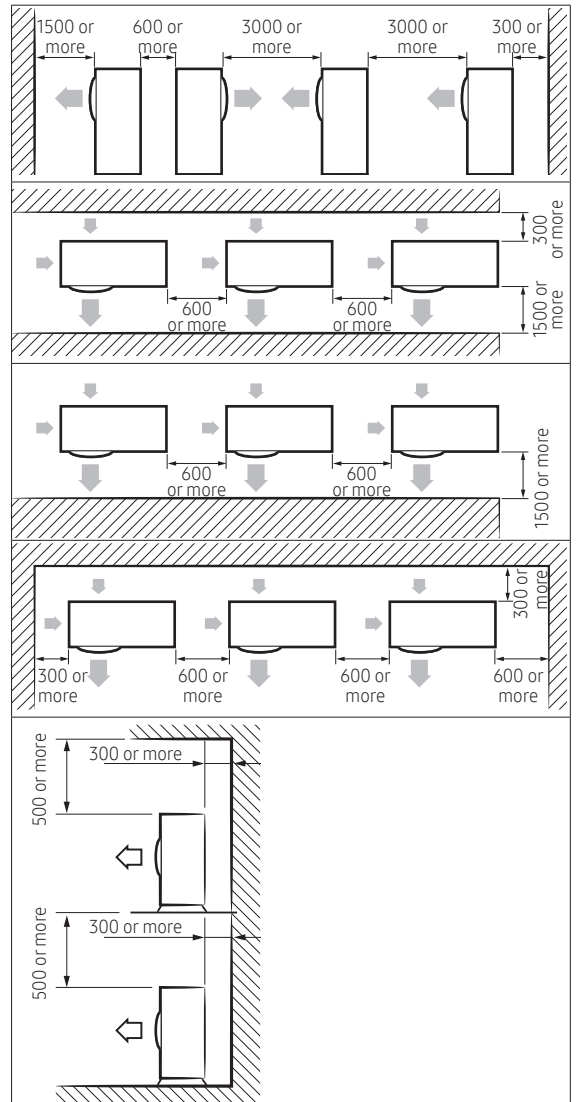







(Unit: mm)



## ⚠ CAUTION

- The outdoor unit must be installed according to the specified distances in order to permit accessibility from each side, to guarantee correct operation, maintenance, and repair of the unit. The components of the outdoor unit must be reachable and removable under safe conditions for people and the unit.

## Step 2 Checking and preparing accessories and tools

3-wire Power Cable (option)	2-wire Assembly Cable (option)
	
Drain Plug	Energy Label
	
Rubber Leg	Installation Manual
	
Flare Nuts, 15.88mm outer pipe diameter	Flare Nuts, 9.52mm outer pipe diameter
	
Tube connector (Pipe 12.70mm; Bolt 9.52mm)	Tube connector (Pipe 12.70mm; Bolt 15.88mm)
	

### NOTE

- Attach Energy Label to the outdoor unit properly when installing.
- Wire assembly cables are optional. If they are not supplied, use standard cables.
- The drain plug and the rubber legs are included only when the air conditioner is supplied without assembly pipes.
- If these accessories are supplied, they are in the accessory package or outdoor unit package.

## Step 3 Fixing the outdoor unit in place

Install the outdoor unit on a rigid and stable base to prevent disturbance from any noise caused by vibration. When installing the unit at a height or in a location exposed to strong winds, fix the unit securely to a support (i.e., a wall or a ground).

- 1 Position the outdoor unit so that the air flow is directed towards the outside, as indicated by the arrows on the top of the unit.
- 2 Attach the outdoor unit to the appropriate support using anchor bolts.
  - The earthing wire for the telephone line cannot be used to earth the air conditioner.
- 3 If the outdoor unit is exposed to strong winds, install shield plates around the outdoor unit, so that the fan can operate correctly.

### NOTE

- Certainly fix up its rubber leg in order to prevent its vibration and noise.

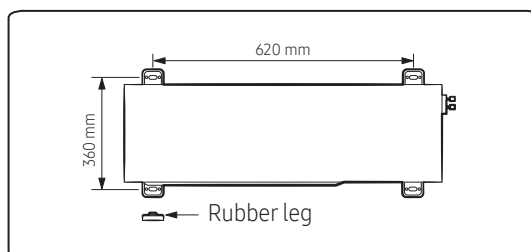

### CAUTION

- Install a drain outlet at the lowest end around the base for outdoor unit drainage
- When installing the outdoor unit on the roof, waterproof the unit and check the ceiling strength.

# Installation Procedure

## Optional: Fixing the outdoor unit to a wall with a rack

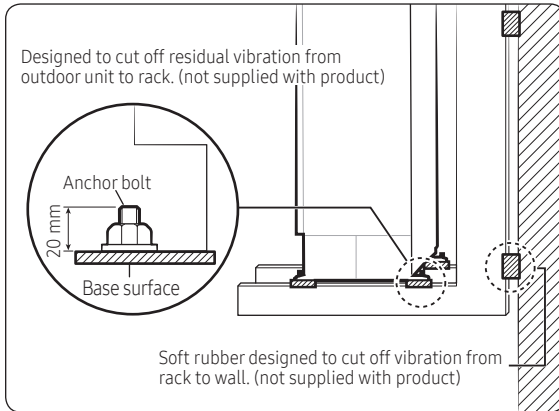

- Install a proper grommet in order to reduce noise and residual vibration transferred by the outdoor unit towards the wall.

### CAUTION

- When installing an air guide duct, be sure to check the following:
  - The screws do not damage the copper pipe.
  - The air guide duct is fixed firmly on the guard fan.

## Step 4 Connecting the power cables, communication cable, and controllers

You must connect the following three electrical cables to the outdoor unit:

- The main power cable between the auxiliary circuit breaker and the outdoor unit.
- The outdoor-to-indoor power cable between the outdoor unit and the indoor unit.
- The communication cable between the outdoor unit and the indoor unit.

### CAUTION

- During installation, make first the refrigerant connections and then the electrical connections. If the unit is uninstalled, first disconnect the electrical cables and then the refrigerant connections.
- Connect the air conditioner to the earthing system before making the electrical connections.

### NOTE

- Especially, if your outdoor unit is the one designed for Russian and European markets, consult the supply authority, if necessary, to estimate and reduce the supply system impedance before installation.



## Connecting the cables to the outdoor unit

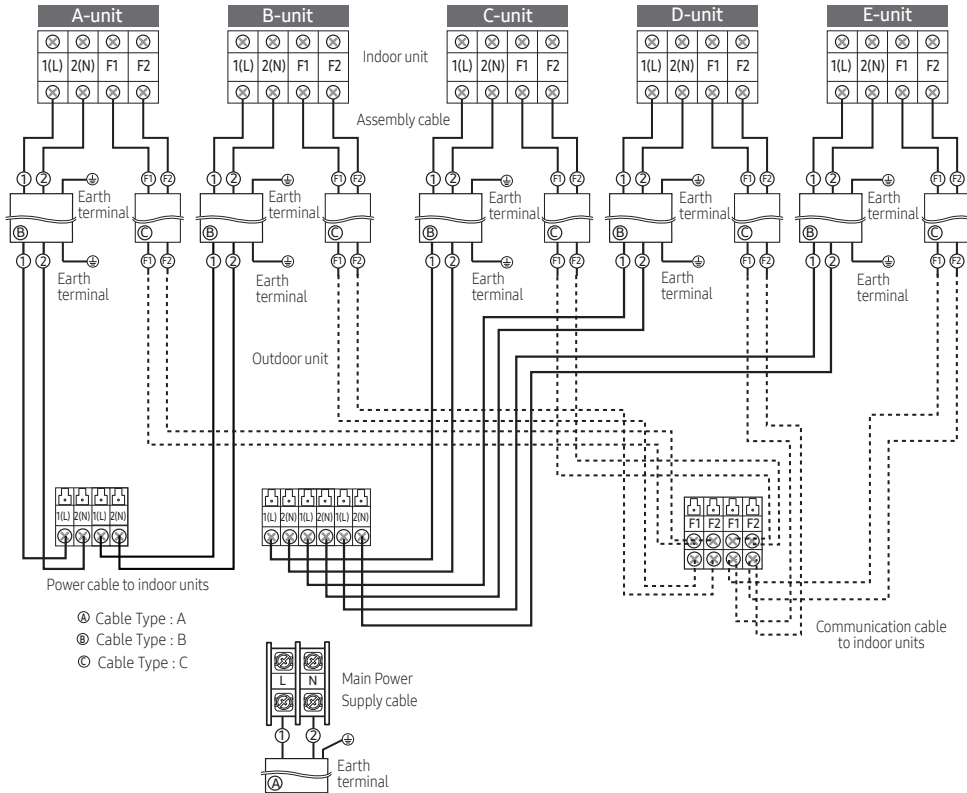

### Specification for circuit breaker and power supply cord

- Power supply cord is not supplied with air conditioner.
- Select the power supply cord in accordance with relevant local and national regulations.
- Wire size must comply with the applicable local and national code.
- Specifications for local wiring power supply cord and branch wiring are in compliance with local cord.

Model		Outdoor Units		Maximun Input Current[A]			Power Supply	
		Rated	Rated	Outdoor	Indoor(Max.)	Total	MCA	MFA
Outdoor Unit	Indoor Unit	Hz	Volts					
AJ100MCJ5EH	5 Room	50	1phase, 220-240	23.0	3.2	26.2	26.2	28.8

### NOTE

1. Power Supply cords of parts of appliances for outdoor use shall not be lighter than polychloroprene sheathed flexible cord. (Code designation IEC:60245 IEC 57 / CENELEC: H05RN-F)
2. Select power supply cord based on MCA.
3. MFA is used to select the circuit breaker and the ground fault circuit interrupter (earth leakage circuit breaker).
4. MCA represents maximum input current.
5. MFA represents capacity which may accept MCA.

### Abbreviations

- MCA : Min. Circuit Amps. (A)
- MFA : Max. Fuse Amps. (A)

Screw	Tighten Torque(kgf.cm)	Position
M4	12.0~18.0	1(L),2(L),L,N,F1,F2

# Installation Procedure









## Tightening power terminal

- Connect the cables to the terminal board using the compressed ring terminal.
- Use rated cables only.
- Connect the cables with driver and wrench that can apply the rated torque to the screws.
- Make sure that appropriate tightening torque is applied for cable connection. If the terminal is loose, arc heat may occur and cause fire and if the terminal is connected too firmly, terminal may get damaged.

## Transmitter installation(option)

- AJ100MCJ5EH

### Accessories (Transmitter: MIM-B13B)

Transmitter MAIN	Transmitter SUB	485 Communication Cable	DC Power Cable (12V)	DC Power Cable (5V)	Communication Cable	Cable Tie	Case
							

1. Turn the power off and take off the cover of the outdoor units.
2. Fix the case with bolts to the side of the control box referring to the figure on the right side.  
In case of FJM outdoor unit, there is not enough space to fix all parts of transmitter. So you may use transmitter main PCB.
3. Attach the transmitter main PCB to the case, then connect F1/F2 lines, R1/R2 lines which are upper controller communication cables and DC 12V power cables to the interface module referring to the figure on page 11. (Upper controller power should be off.)
4. You must check the position of dip switch on the transmitter's main PCB and the main PCB of MH\*/NJ\*/ indoor units. For AQV\*/AJN\*/AR\*/ indoor units, refer to page 26.
5. Assemble a cover of the outdoor unit and turn the power on.
6. Check the communication status.
7. If you install a transmitter to the outdoor unit, every indoor unit which is connected to the outdoor unit can be controlled simultaneously.
8. Each outdoor unit connected to the same centralized controller has its own transmitter.

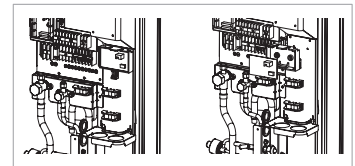

Fix the case with hinges  
(Control Box in the outdoor unit)

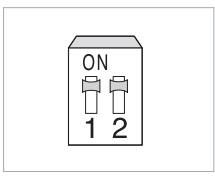
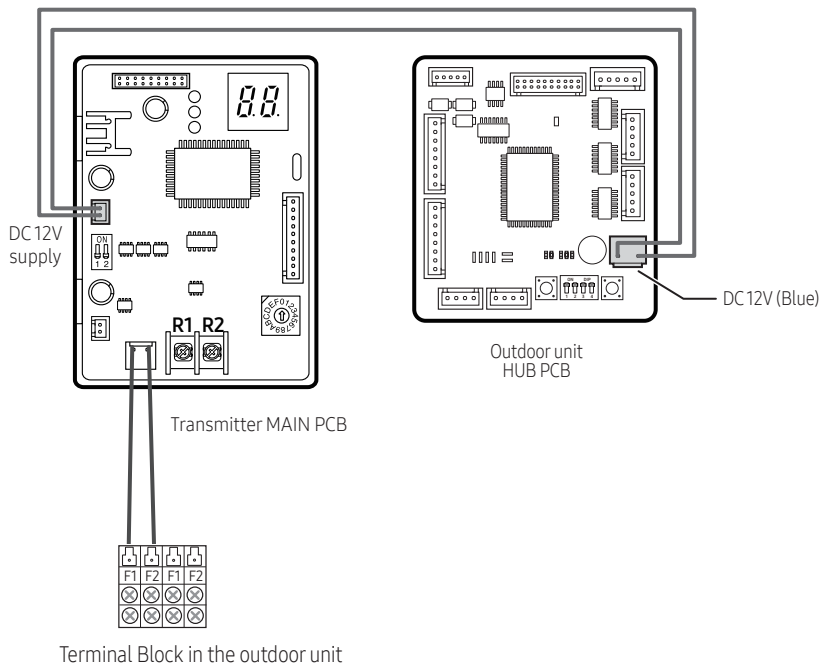

Check the dip switch position on transmitter main PCB as the picture above, "turn ON"

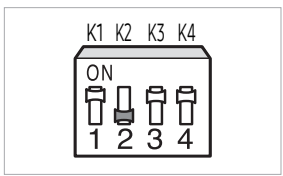

Change DIPswitch-K2 on MH\*\*/NJ\*\*/ indoor units PCB (K2 : ON to OFF). For AJN\*\*/AR\*\*/ indoor units, refer to page 26.

# Installation Procedure

## Outdoor-to-indoor power terminal specifications

- Connect the cables to the terminal board using the compressed ring terminal.
- Cover a solderless ring terminal and a connector part of the power cable and then connect it.

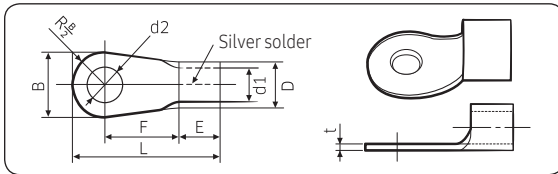

Nominal dimensions for cable (mm <sup>2</sup> )	Nominal dimensions for screw (mm)	B		D		d1		E			L		d2		t
		Standard dimension (mm)	Allowance (mm)	Standard dimension (mm)	Allowance (mm)	Standard dimension (mm)	Allowance (mm)	Min. (mm)	Min. (mm)	Max. (mm)	Standard dimension (mm)	Allowance (mm)	Min. (mm)		
1.5	4	6.6	±0.2	3.4	+0.3 -0.2	1.7	±0.2	4.1	6	16	4.3	+0.2 0	0.7		
	4	8													
2.5	4	6.6	±0.2	4.2	+0.3 -0.2	2.3	±0.2	6	6	17.5	4.3	+0.2 0	0.8		
	4	8.5													
4	4	9.5	±0.2	5.6	+0.3 -0.2	3.4	±0.2	6	5	20	4.3	+0.2 0	0.9		

- Connect the rated cables only.
- Connect using a driver which is able to apply the rated torque to the screws.
- If the terminal is loose, fire may occur caused by arc. If the terminal is connected too firmly, the terminal may be damaged.

Tightening torque (kgf • cm)	
M4	12.0 to 18.0
M5	20.0 to 30.0

- 1N · m = 10 kgf · cm

## ⚠ CAUTION

- When connecting cables, you can connect the cables to the electrical part or connect them through the holes below depending on the spot.
- Connect the communication cable between the indoor and outdoor units through a conduit to protect against external forces, and feed the conduit through the wall together with refrigerant piping.
- Remove all burrs at the edge of the knock-out hole and secure the cable to the outdoor knock-out using lining and bushing with an electrical insulation such as rubber and so on.
- Must keep the cable in a protection tube.
- Keep distances of 50mm or more between power cable and communication cable.
- When the cables are connected through the hole, remove the Plate bottom.

## Outdoor-to-indoor power and communication cables specifications

Indoor power supply		
Power supply	Max/Min (V)	Indoor power cable
1Φ, 220-240V, 50 Hz	±10%	1.5 mm <sup>2</sup> ↑, 3 wires
Communication cable		
0.75 to 1.5 mm <sup>2</sup> , 2 wires		

- Power supply cords of parts of appliances for outdoor use shall not be lighter than polychloroprene sheathed flexible cord. (Code designation IEC:60245 IEC 57 / CENELEC: H05RN-F)
- When installing the indoor unit in a computer room or net work room, use the double shielded (tape aluminium / polyester braid + copper ) cable of FROHH2R type.

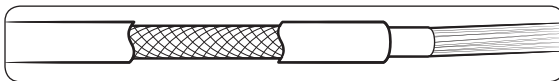

## Step 5 Optional: Extending the power cable

- 1 Prepare the following tools.

Tools	Spec	Shape
Crimping pliers	MH-14	
Connection sleeve (mm)	20xØ6.5 (HxOD)	
Insulation tape	Width 19 mm	
Contraction tube (mm)	70xØ8.0 (LxOD)	

- 2 As shown in the figure, peel off the shields from the rubber and wire of the power cable.
  - Peel off 20 mm of cable shields from the pre-installed tube.



### CAUTION

- For information about the power cable specifications for indoor and outdoor units, refer to the installation manual.
- After peeling off cable wires from the pre-installed tube, insert a contraction tube.

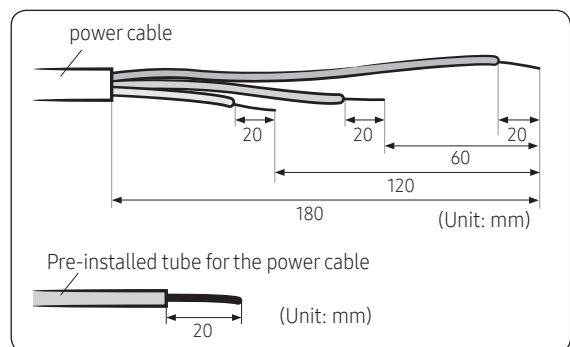

- 3 Insert both sides of core wire of the power cable into the connection sleeve.
  - **Method 1:** Push the core wire into the sleeve from both sides.
  - **Method 2:** Twist the wire cores together and push it into the sleeve.

# Installation Procedure

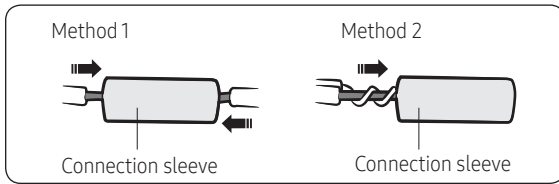

- 4 Using a crimping tool, compress the two points and flip it over and compress another two points in the same location.
- The compression dimension should be 8.0

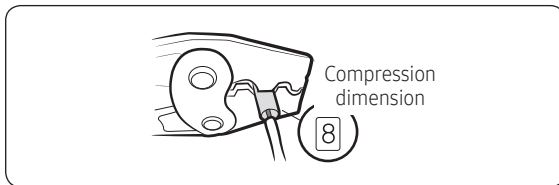

- After compressing it, pull both sides of the wire to make sure it is firmly pressed.

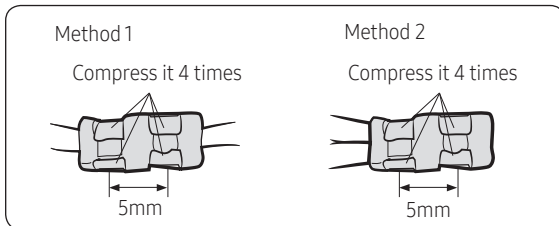

- 5 Wrap it with the insulation tape twice or more and position your contraction tube in the middle of the insulation tape.

Three or more layers of insulation are required.

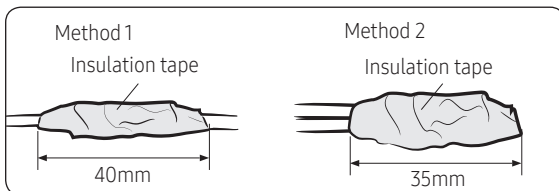

- 6 Apply heat to the contraction tube to contract it.

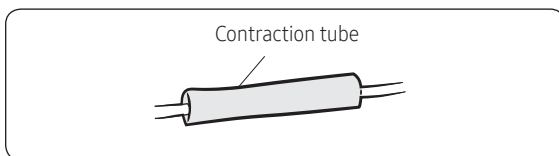

- 7 After tube contraction work is completed, wrap it with the insulation tape to finish.

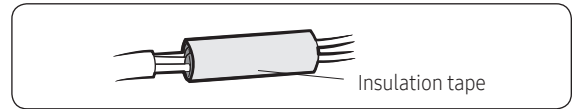

## ⚠ CAUTION

- Make sure that the connection parts are not exposed to outside.
- Be sure to use insulation tape and a contraction tube made of approved reinforced insulating materials that have the same level of withstand voltage with the power cable. (Comply with the local regulations on extensions.)

## ⚠ WARNING

- In case of extending the electric wire, please DO NOT use a round-shaped Pressing socket.
  - Incomplete wire connections can cause electric shock or a fire.

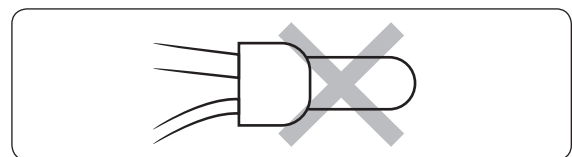

## Step 6 Connecting the refrigerant pipe

### ◆ AJ100MCJ5EH

#### 1 Piping outside diameter.

Indoor unit	Out unit	Power supply Ø, V, Hz	Outside diameter	
			Liquid	Gas
**020/026/ 035/07/09/12** **052/18** **24**	AJ100MCJ5EH	1,220-240, 50/60	1/4"	3/8"
				1/2"
				5/8"

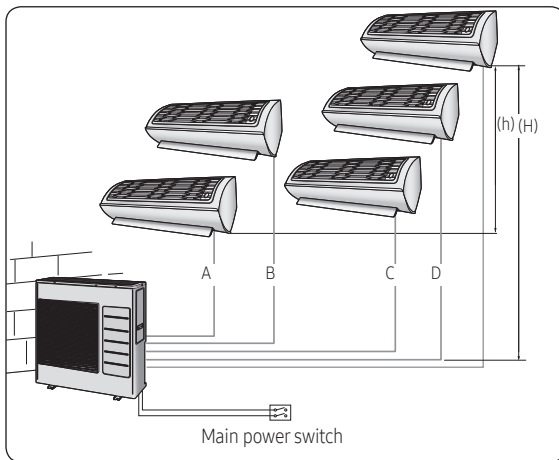

#### 2 Piping length and the height.

	1 Room max length	5 Room total max length	Max height between indoor unit & outdoor unit	Max height between indoor units
Dimension	25m	80m	15m	7.5m
Composition	A,B,C,D,E	A+B+C+D+E	(H)	(h)

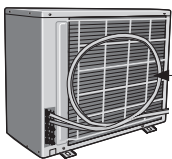

Make at least one round:  
It will reduce noise and vibration

### ⚠ CAUTION

- 3 m as minimum pipe length: It will reduce noise and vibration.
- The appearance of the unit may be different from the diagram depending on the model.

### 📖 NOTE

You can use the Cool and Heat modes in the following conditions :

Model	Cool	Heat
Outdoor temperature	-10 °C to 46 °C	-15 °C to 24 °C

- It could take maximum 60 minutes to operate for the protection of the compressor, if the outdoor temperature is below -5°C.

## Step 7 Optional: Cutting and flaring the pipes

- 1 Make sure that you have the required tools available. (pipe cutter, reamer, flaring tool, and pipe holder)
- 2 If you wish to shorten the pipes, cut it with a pipe cutter, taking care to ensure that the cut edge remains at a 90° angle with the side of the pipe. Refer to the illustrations below for examples of edges cut correctly and incorrectly.

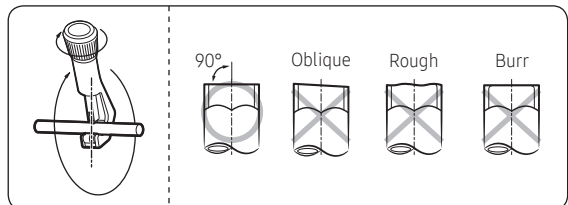

- 3 To prevent any gas from leaking out, remove all burrs at the cut edge of the pipe, using a reamer.
- 4 Slide a flare nut on to the pipe and modify the flare.

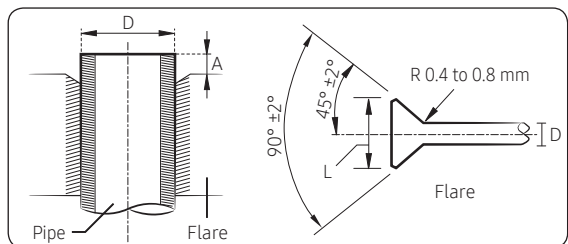

Outer diameter (D)	Depth (A)	Flare dimension (L)
ø6.35 mm	14 to 18	8.7 to 9.1 mm
ø9.52 mm	34 to 42	12.8 to 13.2 mm
ø12.70 mm	49 to 61	16.2 to 16.6 mm
ø15.88 mm	68 to 82	19.3 to 19.7 mm

# Installation Procedure

- 5 Check that the flaring is correct, referring to the illustrations below for examples of incorrect flaring.

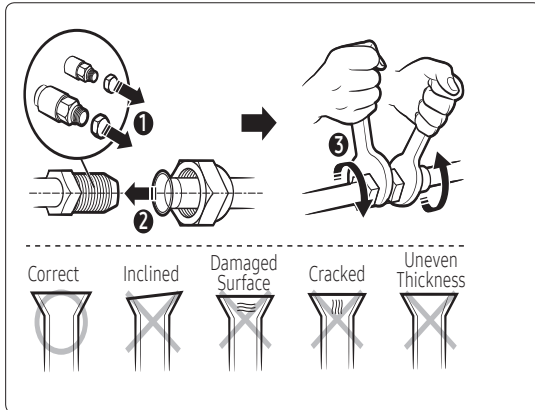

## ⚠ CAUTION

- If the pipes require brazing ensure that OFN(Oxygen Free Nitrogen) is flowing through the system.
- Nitrogen blowing pressure range is 0.02 to 0.05 MPa.

## Step 8 Connecting up and removing air in the circuit

### ⚠ WARNING

- When installing, make sure there is no leakage. When recovering the refrigerant, ground the compressor first before removing the connection pipe. If the refrigerant pipe is not properly connected and the compressor works with the service valve open, the pipe inhales the air and it makes the pressure inside of the refrigerant cycle abnormally high. It may cause explosion and injury.

The outdoor unit is loaded with sufficient R-410A refrigerant. Do not vent R-410A into atmosphere: it is a fluorinated greenhouse gas, covered by Kyoto Protocol, with a Global Warming Potential (GWP) = 2088.

You should purge the air in the indoor unit and in the pipe. If air remains in the refrigerant pipes, it affects the compressor. It may cause reduction of cooling capacity and malfunction. Refrigerant for air purging is not charged in the outdoor unit. Use Vacuum Pump as seen in the picture.

- 1 Check the piping connections.
- 2 Connect the charging hose of low pressure side of manifold gauge to the packed valve having a service port.

Model Name	Valve	
	3/8"	1/2"
AJ100MCJ5EH	2	3

### ⚠ CAUTION

- Make the electrical connection and leave the system into "stand by mode". Do not turn on the system! This is necessary for better vacuum operation (full OPEN position of Electronic Expansion Valve - EEV -).



AJ100MCJ5EH

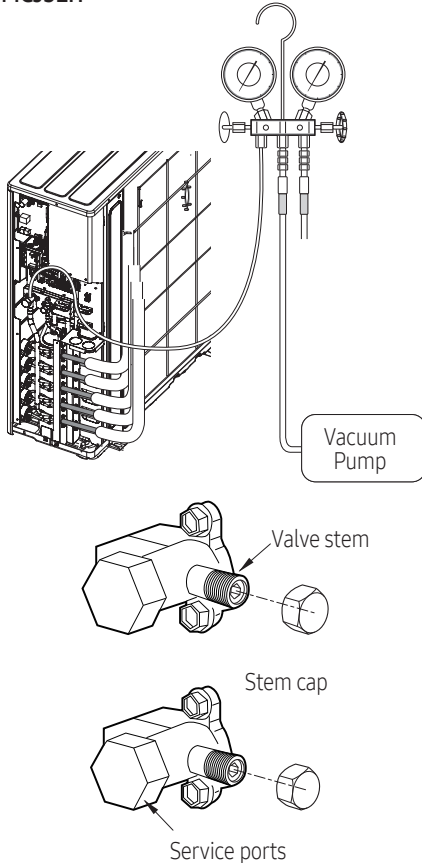

- 3 Open the valve of the low pressure side of manifold gauge counter clockwise.
- 4 Purge the air from the system using vacuum pump for about 30 minutes.
  - Close the valve of the low pressure side of manifold gauge clockwise.
  - Make sure that pressure gauge show  $-0.1\text{MPa}$  ( $-76\text{cmHg}$ ) after about 30 minutes. This procedure is very important in order to avoid gas leak.
  - Turn off the vacuum pump.
  - Remove the hose of the low pressure side of manifold gauge.
- 5 Set valve cork of both liquid side and gas side of packed valve to the open position.
- 6 Mount the valve stem nuts and the service port cap to the valve, and tighten them at the torque of  $183\text{kg}\cdot\text{cm}$  with a torque wrench.

## Step 9 Performing the gas leak test

Before completing the installation (insulation of the cables, hose and piping and fixing of the indoor unit to the installation plate), you must check that there are no gas leaks.

To check for gas leaks on the...	Then, using a leak detector, check the ...
Outdoor unit	Valves on sections A and B.
Indoor unit	Flare nuts at the end of sections C and D.

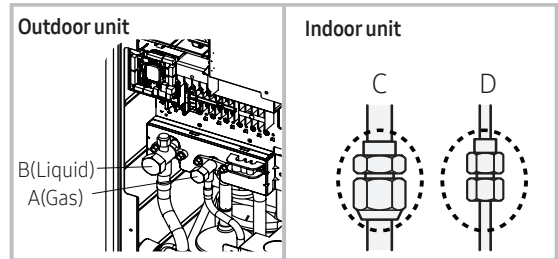

- The designs and shape are subject to change according to the model.

### LEAK TEST WITH NITROGEN (before opening valves)

In order to detect basic refrigerant leaks, before recreating the vacuum and recirculating the R-410A, it is the responsibility of the installer to pressurize the whole system with nitrogen (using a cylinder with pressure reducer) at a pressure above 4 MPa (gauge).

### LEAK TEST WITH R-410A (after opening valves)

Before opening valves, discharge all the nitrogen into the system and create vacuum. After opening valves check leaks using a leak detector for refrigerant R-410A.

Once you have completed all the connections, check for possible leaks using leak detector specifically designed for HFC refrigerants.

# Installation Procedure

## Step 10 Adding refrigerant (R-410A)

### Important information regulation regarding the refrigerant used

This product contains fluorinated greenhouse gases. Do not vent gases into the atmosphere.

### ⚠ CAUTION

- Inform user if system contains 5 tCO<sub>2</sub>e or more of fluorinated greenhouse gases. In this case, it has to be checked for leakage at least once every 12 months, according to regulation n°517/2014. This activity has to be covered by qualified personnel only.
- In case situation above (5 tCO<sub>2</sub>e or more of R-410A), installer (or recognized person which has responsibility for final check) has to provide a maintenance book, with all the information recorded according to REGULATION (EU) No 517/2014 OF THE EUROPEAN PARLIAMENT AND OF THE COUNCIL of 16 April 2014 on fluorinated greenhouse gases.

Please fill in the following with indelible ink on the refrigerant charge label supplied with this product and on this manual.

- ①: The factory refrigerant charge of the product.
- ②: The additional refrigerant amount charged in the field.
- ① + ②: The total refrigerant charge.

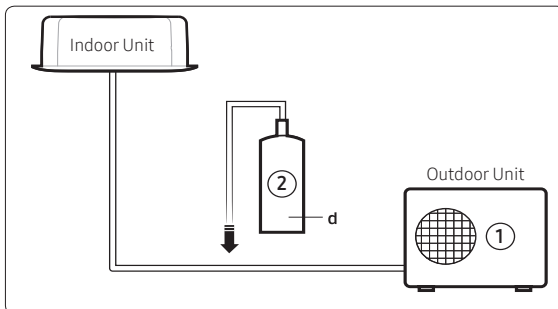

Unit	kg	tCO <sub>2</sub> e
①, a		
②, b		
① + ②, c		

Refrigerant type	GWP value
R-410A	2088

- GWP: Global Warming Potential
- Calculating tCO<sub>2</sub>e : kg x GWP / 1000

### 📖 NOTE

- Factory refrigerant charge of the product: see unit name plate
- Additional refrigerant amount charged in the field (Refer to the above information for the quantity of refrigerant replenishment.)
- Total refrigerant charge
- Refrigerant cylinder and manifold for charging

### Calculating the quantity of refrigerant to add

The quantity of additional refrigerant is variable according to the installation situation. Thus, make sure the outdoor unit situation before adding refrigerant.

If you install the excessive length of pipe, add additional refrigerant as 20g per unit meter ; refer to the table below.

Refer to the Service Manual for more details on this operation.

Model	Total connecting pipe length (L)	Adding refrigerant
AJ100MCJ5EH	LT ≤ 40m	Chargeless
	LT > 40m	(LT - 40m) x 20g

### Charging the refrigerant under conditions of liquid by using a liquid pipe

R410A is a mixed type of refrigerant. It is necessary for recharging under conditions of liquid. When recharging refrigerant from the refrigerant cylinder to the equipment, follow the instructions below.

- Before recharging, check whether the cylinder has a siphon or not. There are two ways to recharge the refrigerant.

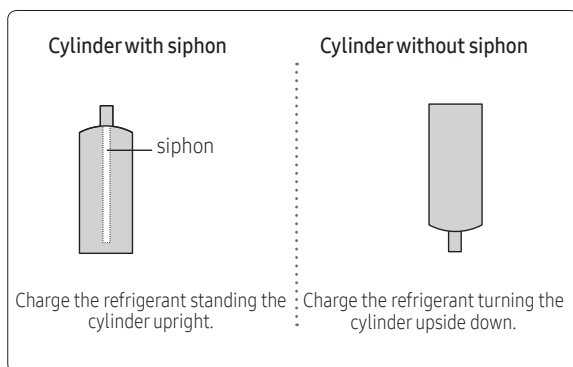

### NOTE

- If R410A refrigerant is charged with gas, the composition of the charged refrigerant changes and the characteristics of the equipment vary.
- During the measuring operation of refrigerant quantity added use an electronic balance. If cylinder doesn't have syphon, upset it.

## Step 11 Connecting the drain hose to the outdoor unit

When heating, ice may accumulate. During the process of defrosting, check if condensation draining is adequate.

For adequate draining, do the following :

- 1 Insert the drain plug into the drain hole on the underside of the outdoor unit.
- 2 Connect the drain hose to the drain plug.
- 3 Ensure that condensation draining is adequate.

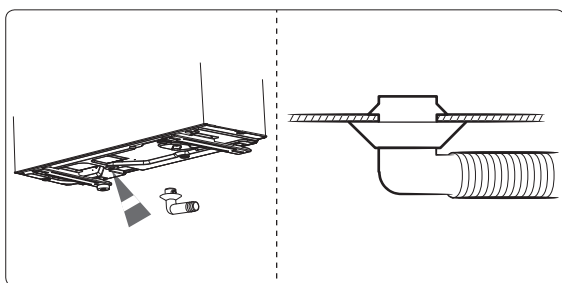

## Step 12 Checking the earthing

If the power distribution circuit does not have a earthing or the earthing does not comply with specifications, an earthing electrode must be installed. The corresponding accessories are not supplied with the air conditioner.

- 1 Select an earthing electrode that complies with the specifications given in the illustration.
- 2 Connect the flexible hose to the flexible hose port.
  - In damp hard soil rather than loose sandy or gravel soil that has a higher earthing resistance.
  - Away from underground structures or facilities, such as gas pipes, water pipes, telephone lines and underground cables.
  - At least two metres away from a lightning conductor earthing electrode and its cable.

### NOTE

- The earthing wire for the telephone line cannot be used to ground the air conditioner.

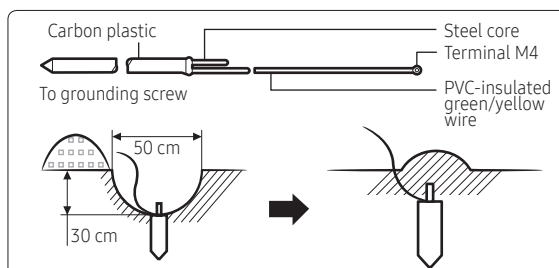

- 3 Finish wrapping insulating tape around the rest of the pipes leading to the outdoor unit.
- 4 Install a green/yellow coloured earthing wire:
  - If the earthing wire is too short, connect an extension lead in a mechanical way and wrap it with insulating tape (do not bury the connection).
  - Secure the earthing wire in position with staples.

### NOTE

- If the earthing electrode is installed in an area with heavy traffic, its wire must be connected securely.
- 5 Carefully check the installation by measuring the earthing resistance with a earth resistance tester. If the resistance is above the required level, drive the electrode deeper into the ground or increase the number of earthing electrodes.
  - 6 Connect the earthing wire to the electrical component box inside of the outdoor unit.

# Installation Procedure

## Step 13 Setting an indoor unit address and installation option

### Setting the indoor unit address and inspecting the pipes automatically

#### ⚠ CAUTION

- This product is prohibited one indoor unit installation. Don't use pipe checking operation and auto addressing mode when one indoor unit is installed.

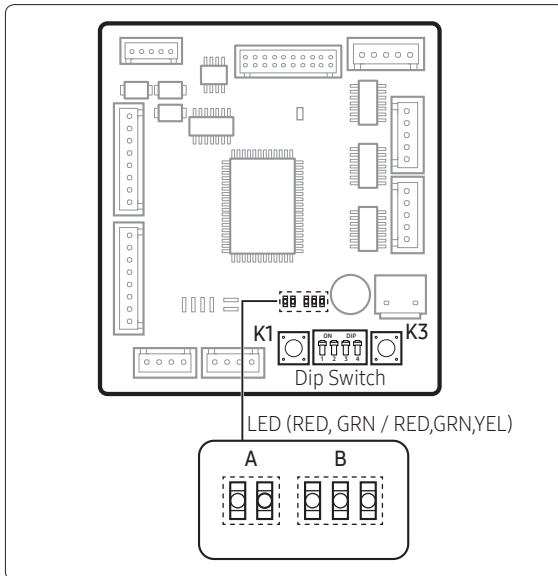

- ●: On, ○: Off, ⊙: Blinking

- Turn on the outdoor unit, and then check whether the LED indications are displayed as shown in the following table:

A		B		
RED	GRN	RED	GRN	YEL
●	○	●	○	○

- If the LED indications of the part B are different from the indications shown in the table, see Troubleshooting on page 30 and take corrective actions.

- Press the K1 button once to start the address setting and pipe inspection automatically.

The LED indications change as shown in the following table, and the automatic address setting starts.

A		B		
RED	GRN	RED	GRN	YEL
○	●	●	○	○

- When communication between the outdoor unit and the indoor units starts normally, the LED indications change as shown in the following table.

After this, the outdoor unit starts the automatic pipe inspection.

A		B		
RED	GRN	RED	GRN	YEL
○	●	●	⊙	○

- Check whether the automatic pipe inspection is finished successfully.

- If all the installation procedures (including automatic address setting and pipe inspection) are finished successfully, the LED indications change as shown in the following table, and the outdoor unit stops.

A		B		
RED	GRN	RED	GRN	YEL
○	○	●	⊙	○

- If automatic address setting or pipe installation fails the LED indications change as shown in the following table, and the outdoor unit stops.

Turn off all indoor and outdoor units, see Troubleshooting on page 30 and take corrective actions, and then take all steps again starting from 1.

A		B		
RED	GRN	RED	GRN	YEL
○	●	Display Error Specification (Refer to the Troubleshooting section)		

### Installing an additional indoor unit after installation

- 1 After installing the indoor unit while the outdoor unit is turned off, turn on the outdoor unit, and check if the LED indications change as shown in the following table:

A		B		
RED	GRN	RED	GRN	YEL
○	○	●	○	○

- 2 Press the K1 button once. The LED indications change as shown in the following table.

A		B		
RED	GRN	RED	GRN	YEL
○	●	●	○	○

- 3 After a while, the LED indications change as shown in the following table.

A		B		
RED	GRN	RED	GRN	YEL
○	○	●	◐	○

- 4 Press the K1 button to start a reinstallation. (Refer to 3 and 4 in Setting the indoor unit address and inspecting the pipes automatically.

A		B		
RED	GRN	RED	GRN	YEL
○	●	●	◐	○

### Setting the indoor unit addresses manually

- 1 Turn off the switch 1 of the DIP switch, and then turn on the outdoor unit.

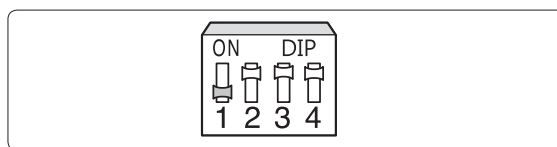



- 2 Manually set the indoor unit options by referring to page 22~26.
- 3 Press the K3 button once or reset the outdoor unit.

#### NOTE

- Key information

K1	Pipe Checking Operation
K3	Reset

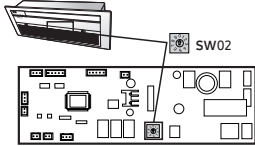
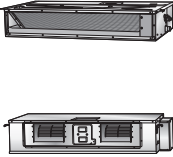
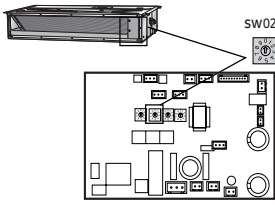
# Installation Procedure

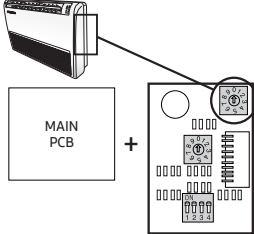
TYPE	PICTURE	MODEL	TO SET ADDRESSING MANUALLY BY ROTARY SWITCH "SW02"
SLIM1 WAY		MH026FS** MH035FS**	
SLIM DUCT MSP-DUCT		NJ026LHX** NJ035LHX** MH052FU**	
CONSOLE		MH026FJ** MH035FJ** MH052FJ**	

ROTARY SWITCH "SW02" POSITION ACCORDING TO REFRIGERANT CIRCUIT CONNECTED  
(0=A; 1=B; 2=C; 3=D; 4=E)

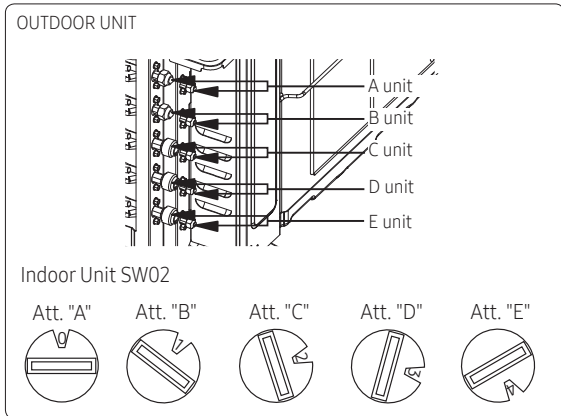

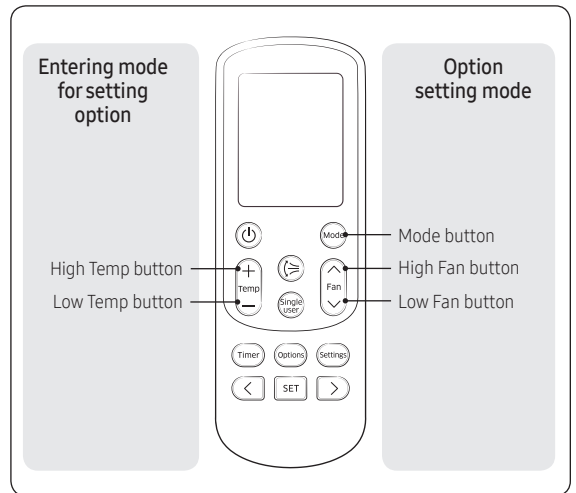

## Setting Option (AJN\*\*/AR\*\*)



### Setting Option

- 1 Remove batteries from the remote controller
- 2 Insert batteries and enter the option setting mode while pressing High Temp button and Low Temp button.

- 3 Each time you press Low Fan button, 7-seg on left side is increased by "1" and each time you press High Fan button, 7-seg on right side is increased by "1"
- 4 You press  button to move to the next setting page.
- 5 After setting option, press  button to check whether the option code you input is correct or not.

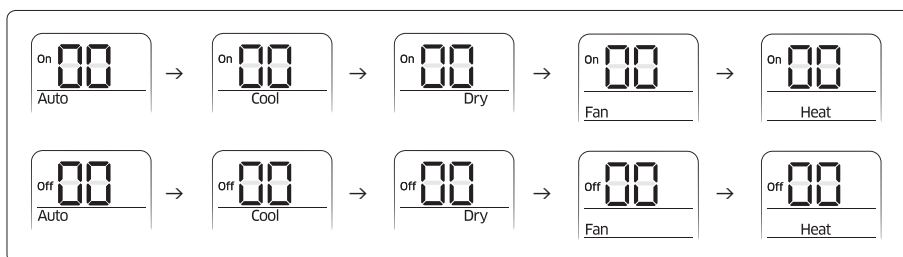



- 6 Press operation button  with the direction of remote control for set.







### CAUTION

- SEG1, SEG7, SEG13, SEG19 are not set as page option.
- Set the SEG1, SEG7 as ON status and SEG13, SEG19 as OFF status.
  - Set the each option separately since you cannot set the ADDRESS setting and indoor unit installation setting option at the same time.

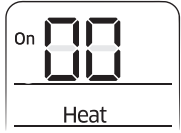
### The procedure of setting option

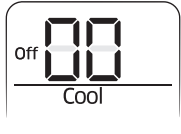
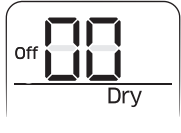
Operation	Indication
<b>Step 1</b> 1 Remove the batteries from the remote controller. 2 Insert batteries while pressing High Temp Button and Low Temp Button.	
<b>Step 2</b> 1 Press Low Fan button to enter SEG2 value. 2 Press High Fan button to enter SEG3 value.	
<b>Step 3</b> Press Mode button to be change to Cool mode in the ON status. 1 Press Low Fan button to enter SEG4 value. 2 Press High Fan button to enter SEG5 value.	
<b>Step 4</b> Press Mode button to be changed to DRY mode in the ON status. 1 Press Low Fan button to enter SEG6. 2 Press High Fan button to enter SEG8.	

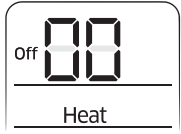
# Installation Procedure

Operation	Indication
<p><b>Step 5</b> Press Mode button to be changed to FAN mode in the ON status.</p> <ol style="list-style-type: none"> <li>1 Press Low Fan button to enter SEG9 value.</li> <li>2 Press High Fan button to enter SEG10 value.</li> </ol>	
<p><b>Step 6</b> Press Mode button to be changed to HEAT mode in the ON status.</p> <ol style="list-style-type: none"> <li>1 Press Low Fan button to enter SEG11 value.</li> <li>2 Press High Fan button to enter SEG12 value.</li> </ol>	
<p><b>Step 7</b> Press Mode button to be changed to AUTO mode in the OFF status.</p> <ol style="list-style-type: none"> <li>1 Press Fan button to enter SEG14 value.</li> <li>2 Press High Fan button to enter SEG15 value.</li> </ol>	
<p><b>Step 8</b> Press Mode button to be changed to Cool mode in the OFF status.</p> <ol style="list-style-type: none"> <li>1 Press Low Fan button to enter SEG16 value.</li> <li>2 Press High Fan button to enter SEG17 value.</li> </ol>	
<p><b>Step 9</b> Press Mode button to be changed to DRY mode in the OFF status.</p> <ol style="list-style-type: none"> <li>1 Press Low Fan button to enter SEG18 value.</li> <li>2 Press High Fan button to enter SEG20 value.</li> </ol>	
<p><b>Step 10</b> Press Mode button to be changed to FAN mode in OFF status</p> <ol style="list-style-type: none"> <li>1 Press Low Fan button to enter SEG21 value.</li> <li>2 Press High Fan button to enter SEG22 value.</li> </ol>	
<p><b>Step 11</b> Press Mode button to be changed to HEAT mode in the OFF status</p> <ol style="list-style-type: none"> <li>1 Press Low Fan button to enter SEG23 value.</li> <li>2 Press High Fan button to enter SEG24 value.</li> </ol>	
<p><b>Step 12</b> Press Mode button to check whether the option code you entered is correct or not. Press operation button  to enter option.</p>	



## Setting an indoor unit address (MAIN/RMC)

- 1 Check whether power is supplied or not.
  - When the indoor unit is not plugged in, there should be additional power supply in the indoor unit.

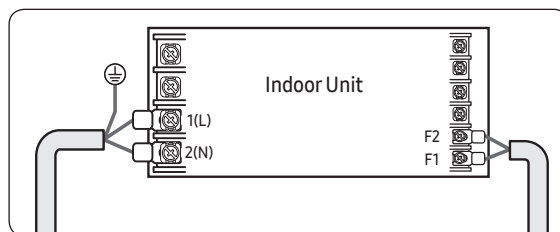

- 2 The panel(display ) should be connected to an indoor unit to receive option.
- 3 Before installing the indoor unit, assign an address to the indoor unit according to the air conditioning system plan.
- 4 Assign an indoor unit address by wireless remote controller.
  - The initial setting status of indoor unit ADDRESS(MAIN/RMC) is "0A0000-100000-200000-300000"
  - There is no need to assign extra ADDRESS for 1:1 installation between indoor unit and outdoor unit.

Option No. : 0AXXXX-1XXXXX-2XXXXX-3XXXXX

Option	SEG1		SEG2		SEG3		SEG4		SEG5		SEG6	
Explanation	Page		Mode		Setting main address		100-digit of indoor unit address		10-digit of indoor unit		A single digit of indoor unit	
Indication and details	Indication	Details	Indication	Details	Indication	Details	Indication	Details	Indication	Details	Indication	Details
		0		A		0	No Main address	0~9	100-digit	0~9	10-digit	0~9
					1	Main address setting mode						
Option	SEG7		SEG8		SEG9		SEG10		SEG11		SEG12	
Explanation	PAGE				Setting RMC address				Group channel(*16)		Group address	
Indication and Details	Indication	Details	Indication	Details	Indication	Details	Indication	Details	Indication	Details	Indication	Details
	1				0	No RMC address			RMC1	1~F	RMC2	1~F
				1	RMC address setting mode							

\* You must set RMC address setting mode when using the centralized Control.

### **⚠ CAUTION**

- When "A"~"F" is entered to SEG4~6, the indoor unit MAIN ADDRESS is not changed.
- If you set the SEG 3 as 0, the indoor unit will maintain the previous MAIN ADDRESS even if you input the option value of SEG4~6.
- If you set the SEG 9 as 0, the indoor unit will maintain previous RMC ADDRESS even if you input the option value of SEG11~12.

- 5 The MAIN address is for communication between the indoor unit and the outdoor unit. Therefore, you must set it to operate the air conditioner properly

# Installation Procedure

## Setting an indoor unit installation option (suitable for the condition of each installation location)

- 1 Check whether power is supplied or not.
  - When the indoor unit is not plugged in, there should be additional power supply in the indoor unit.

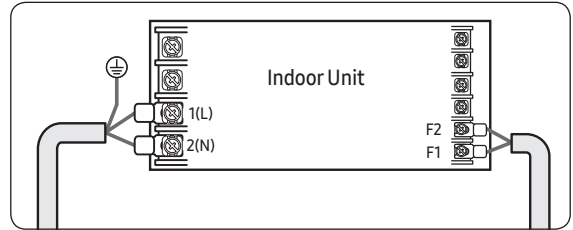





- 2 The panel(display ) should be connected to an indoor unit to receive option.
- 3 Before installing the indoor unit, assign an option to the indoor unit according to the air conditioning system plan.
  - The default setting of an indoor unit installation option is "02000-100000-200000-300000".
  - Individual control of a remote controller(SEG20) is The function that controls an indoor unit individually when there is more than one indoor unit.
- 4 Set the indoor unit option by wireless remote controller.
  - When entering Address option, connect remote controller receiver.

Option	SEG1		SEG2		SEG3		SEG4		SEG5		SEG6	
Explanation	PAGE		MODE						Central control			
Indication and Details	Indication	Details	Indication	Details	Indication	Details	Indication	Details	Indication	Details	Indication	Details
	0		2		0		0		0	No use	0	
									1	Use		
Option	SEG7		SEG8		SEG9		SEG10		SEG11		SEG12	
Explanation	PAGE										Master / Slave	
Indication and Details	Indication	Details	Indication	Details	Indication	Details	Indication	Details	Indication	Details	Indication	Details
	1		0		0		0		0		0	Slave
											1	Master
Option	SEG13		SEG14		SEG15		SEG16		SEG17		SEG18	
Explanation	PAGE		External control		External control output				Buzzer			
Indication and Details	Indication	Details	Indication	Details	Indication	Details	Indication	Details	Indication	Details	Indication	Details
			0	No use	0	Thermo ON	0		0	Use	0	
			1	On/Off control	1	Operation ON	0		1	No Use	0	
			2	Off control								
			3	Window On/Off control1)								
Option	SEG19		SEG20		SEG21		SEG22		SEG23		SEG24	
Explanation	PAGE											
Indication and Details	Indication	Details	Indication	Details	Indication	Details	Indication	Details	Indication	Details	Indication	Details
	3		0		0		0		0		0	

- ✳ If you input a number other than 0~4 of the individual control of the indoor unit(SEG20), the indoor is set as "indoor 1".
- The window on/off function applies to the following unit
    - AJN\*\*\*/AR\*\*

## Setting to Cool or Heat only mode

This function enables the indoor units connected to the outdoor unit to operate in a specific mode.

AJXX*MCJ*EH			
Set the indoor mode	Switch	Switch Selection	
		3	4
Cooling and Heating		OFF	OFF
		ON	ON
Only Cooling		ON	OFF
Only Heating		OFF	ON

## Step 14 Cool and Heat modes operation test

After installing the outdoor and indoor units, test the **Cool** and **Heat** modes.

- When you test the **Cool** mode, set the set temperature of the indoor unit to the lowest one. And when you test the **Heat** mode, set the set temperature of the indoor unit to the highest one.
- Check if each indoor unit operates normally and then also check if all indoor units operate normally together.
  - Check both of the Cool and Heat modes.
- About 20 minutes after the air conditioner is started, check the temperature difference between the air inlet and outlet of the indoor unit. If the temperature difference is larger than the value given in the following table, the operation is normal.

Mode	Temperature
Cool	Approximately 8 °C
Heat	Approximately 12 °C

### CAUTION

- If the outdoor unit is turned off and then immediately turned on again, the compressor does not operate for about 3 minutes.
- During the Cool mode, frost may temporarily develop on valves and other parts.

# Extra Procedures

## Pumping down refrigerant

### WARNING

- After installing the product, be sure to perform leak tests on the piping connections. After pumping down refrigerant to inspect or relocate the outdoor unit, be sure to stop the compressor and then remove the connected pipes.
  - Do not operate the compressor while a valve is open due to refrigerant leakage from a pipe or an unconnected or incorrectly connected pipe. Failure to do so may cause air to flow into the compressor and too a high pressure to develop inside the refrigerant circuit, leading to an explosion or product malfunction.

Pump-down is an operation intended to collect all the system refrigerant in the outdoor unit.

This operation must be carried out before disconnecting the refrigerant pipe in order to avoid refrigerant loss to the atmosphere.

- 1 Turn the system on in cooling with fan operating at high velocity and then let the compressor run for more than 5 minutes. (Compressor will immediately start, provided 3 minutes have elapsed since the last stop.)
- 2 Release the valve caps on High and Low pressure side.
- 3 Use L-wrench to close the valve on the high pressure side.
- 4 After approximately 2 minute, close the valve on the low pressure side.
- 5 Stop operation of the air conditioner by pressing the (Power) button on the indoor unit or remote control.
- 6 Disconnect the pipes.

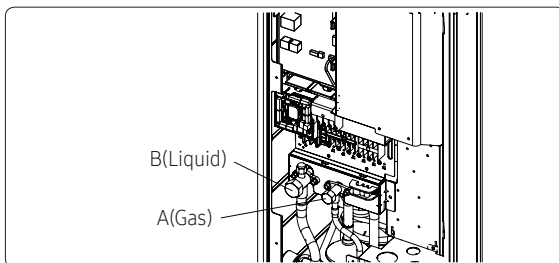

## Relocating the indoor and outdoor units

- 1 Pump down refrigerant. See **Pumping down refrigerant** on page 28.
- 2 Remove the power cord.
- 3 Disconnect the assembly cable from the indoor and outdoor units.
- 4 Remove the flare nuts connecting the indoor units and the pipes. At this time, cover the pipes of the indoor unit and the other pipes using a cap or vinyl plug to avoid foreign material entering.
- 5 Disconnect the pipes connected to the outdoor units. At this time, cover the valve of the outdoor units and the other pipes using a cap or vinyl plug to avoid foreign material entering.

Note: Make sure you do not bend the connection pipes in the middle and store together with the cables.
- 6 Move the indoor and outdoor units to a new location.
- 7 Remove the mounting plate for the indoor unit and move it to a new location.

## Using the stop valve

### Opening the stop valve

- 1 Open the cap and turn the stop valve anticlockwise by using a hexagonal wrench.
- 2 Turn it until the axis is stopped.

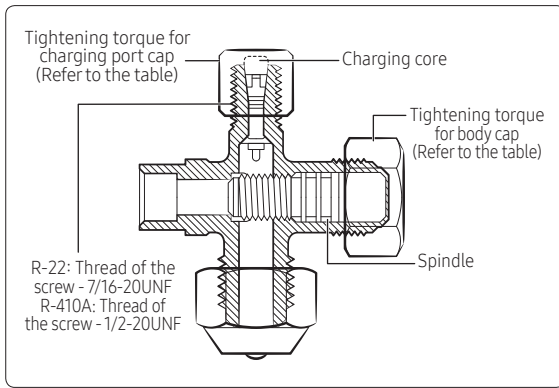

- 4 Tighten the cap securely.

Outer Diameter (mm)	Tightening torque	
	Body cap (N•m)	Charging port cap (N•m)
Ø6.35	20 to 25	10 to 12
Ø9.52	20 to 25	
Ø12.70	25 to 30	
Ø15.88	30 to 35	

(1 N•m=10 kgf•cm)

### NOTE

- Do not apply excessive force to the stop valve and always use special instruments. Otherwise, the stopping box can be damaged and the back sheet can leak.
- If the watertight sheet leaks, turn the axis back by half, tighten the stopping box, then check the leakage again. If there is no leakage any more, tighten the axis entirely.

### Closing the stop valve

- 1 Remove the cap.
- 2 Turn the stop valve clockwise by using a hexagonal wrench.
- 3 Tighten the axis until the valve reached the sealing point.
- 4 Tighten the cap securely.

### CAUTION

- When you use the service port, always use a charging hose, too.
- Check the leakage of refrigerant gas after tightening the cap.
- Must use a spanner and wrench when you open/ tighten the stop valve.

# Appendix

## Troubleshooting

The table below list the self-diagnostic routines. For some of error, you must contact an authorized service center.

If an error occurs during the operation, it is displayed on the outdoor unit HUB PCB.

- The error codes in the list are for reference only. They are not displayed on the outdoor unit HUB PCB.
- If an error occurs while the product is operating normally, all LEDs of the A part are turned off.
- If an error occurs during the installation, the green LED of the A part turns on. Take corrective actions, and then see Setting the indoor unit addresses automatically on page 20 and proceed with setting the indoor unit addresses again.
- ● : On, ○ : Off, ⊙ : Blinking

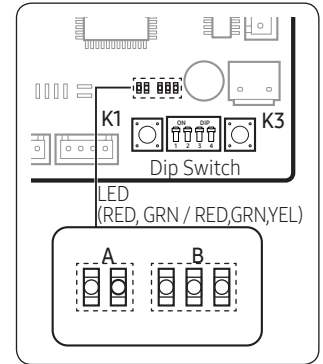

Display (B part)			Error Code	Explanation	Remark
Red	Green	Yellow			
⊙	●	●	E201	The number of indoor unit mismatched	
			E202	Communication error between the outdoor and indoor unit	
●	●	⊙	E203	Outdoor communication error between main micom and inverter micom	
⊙	○	●	E206	Outdoor communication error between main micom and hub micom	
⊙	○	⊙	E221	Outside temperature sensor error (Short/Open)	
⊙	●	⊙	E237	Condenser temperature sensor error (Short/Open)	
○	⊙	⊙	E251	Compressor Discharge temperature sensor error (Short/Open)	
○	○	⊙	E320	Compressor OLP sensor error (Short/Open)	
⊙	⊙	○	E330	EvaIn1 Sensor error (Short/Open)	
			E331	EvaIn2 Sensor error (Short/Open)	
			E332	EvaIn3 Sensor error (Short/Open)	
			E333	EvaIn4 Sensor error (Short/Open)	
			E334	EvaIn5 Sensor error (Short/Open)	
⊙	⊙	⊙	E335	EvaOut1 Sensor error (Short/Open)	
			E336	EvaOut2 Sensor error (Short/Open)	
			E337	EvaOut3 Sensor error (Short/Open)	
			E338	EvaOut4 Sensor error (Short/Open)	
			E339	EvaOut5 Sensor error (Short/Open)	

Display (B part)			Error Code	Explanation	Remark
Red	Green	Yellow			
○	⊙	●	E401	Outdoor unit freezing - Safety control (Compressor stop)	Check pipe length, indoor unit filter, refrigerant leakage/charge and service port
			E404	Outdoor unit overload - Safety control (Compressor stop)	Check pipe length, refrigerant leakage/charge
			E440	High temperature(over 30°C) or low temperature(under -10°C) of outdoor as heating mode	
			E441	Low temperature(under -10°C) of outdoor as cooling mode	
●	○	⊙	E416	Outdoor unit high discharge temperature - Safety control (Compressor stop)	Check pipe length, refrigerant leakage/charge
○	○	●	E458	Outdoor Fan Error	
○	⊙	○	E461	Inverter compressor starting failure (5 times)	
●	⊙	●	E462	Compressor trip by input current control mode (PFC over current)	
○	⊙	●	E463	Compressor trip by OLP temperature control mode	
⊙	○	○	E464	DC Peak system error (Over current)	
○	●	⊙	E465	Compressor Vlimit Error	
⊙	●	○	E466	Inverter DC link Voltage error (under 150V, over 410V)	
			E483	H/W Detect DC Link over voltage Error	
●	○	●	E467	Abnormal compressor running (Compressor Rotation Error)	
●	⊙	⊙	E468	Current sensor error (Short/Open)	
⊙	⊙	●	E469	DC-Link voltage sensor error (Short/Open)	
			E488	Error of the input current sensor	
○	●	○	E470	Outdoor unit EEPROM Error	
			E471	Inverter micom option read/write error	
●	⊙	⊙	E474	Inverter IPM Heat Sink sensor error (Short/Open)	
			E485	Inverter input current sensor error (Short/Open)	
⊙	●	○	E484	PFC Overload error (Over current)	
○	●	⊙	E500	Inverter IPM over heat error	
○	●	●	E554	The refrigerant leaks completely from the outdoor unit.	

**SAMSUNG ELECTRONICS CO., LTD.**

107, Hanamsandan 6beon-ro, Gwangsan-gu, Gwangju-si, Korea 62218

**Samsung Electronics**

Service Department

PO Box 12987, Blackrock, Co. Dublin. Ireland

or

Blackbushe Business Park, Yateley, GU46 6GG. UK

