



Air Conditioner installation manual

imagine the possibilities

Thank you for purchasing this Samsung product.

SAMSUNG

Contents

Preparation

Safety precautions	3
Required tools for installation	6
Accessories	6
Selecting a location for installation	7
Required space for product installation	7

Installation

Installing an indoor unit	8
Connecting a refrigerant pipe	9
Cutting or flaring a pipe	10
Leak test and insulation	11
Installing a drain pipe	13
Connecting a drain hose	14
Leak test	14
Wiring work	15
Setting an indoor unit address and installation option	21
Changing a specific option	32

Others

Troubleshooting	33
Checking after installation	35
Trial operation and transference to a user	35

Safety precautions

Before installing the product, look through the following 'Warning' and 'Caution'. Since the contents below are written for your safety, please keep them rigorously.

*** This model uses R-410A refrigerant.**

- If impurities(moisture, foreign matters)are mixed with the new refrigerant R-410A, product capacity and reliability can deteriorate. Please comply with regulations when installing refrigerant pipes.
- When mixed refrigerant is charged, it should be liquid type.
(If gas type mixed refrigerant is charged, product capacity and reliability can deteriorate.)



WARNING

- Always disconnect the air conditioner from the power supply before servicing it or accessing its internal components.
- Verify that installation and testing operations are performed by qualified personnel.
- Verify that the air conditioner is not installed in an easily accessible area.

General information

- ▶ Carefully read the content of this manual before installing the air conditioner and store the manual in a safe place in order to be able to use it as reference after installation.
- ▶ For maximum safety, installers should always carefully read the following warnings.
- ▶ Store the operation and installation manual in a safe location and remember to hand it over to the new owner if the air conditioner is sold or transferred.
- ▶ This manual explains how to install an indoor unit with a split system with two SAMSUNG units. The use of other types of units with different control systems may damage the units and invalidate the warranty. The manufacturer shall not be responsible for damages arising from the use of non compliant units.
- ▶ The manufacturer shall not be responsible for damage originating from unauthorized changes or the improper connection of electric and hydraulic lines. Failure to comply with these instructions or to comply with the requirements set forth in the "Operating limits" table, included in the manual, shall immediately invalidate the warranty.
- ▶ The air conditioner should be used only for the applications for which it has been designed: the indoor unit is not suitable to be installed in areas used for laundry.
- ▶ Do not use the units if damaged. If problems occur, switch the unit off and disconnect it from the power supply.
- ▶ In order to prevent electric shocks, fires or injuries, always stop the unit, disable the protection switch and contact SAMSUNG's technical support if the unit produces smoke, if the power cable is hot or damaged or if the unit is very noisy.
- ▶ Always remember to inspect the unit, electric connections, refrigerant tubes and protections regularly. These operations should be performed by qualified personnel only.
- ▶ The unit contains moving parts, which should always be kept out of the reach of children.
- ▶ Do not attempt to repair, move, alter or reinstall the unit. If performed by unauthorized personnel, these operations may cause electric shocks or fires.
- ▶ Do not place containers with liquids or other objects on the unit.
- ▶ All the materials used for the manufacture and packaging of the air conditioner are recyclable.
- ▶ The packing material and exhaust batteries of the remote control(optional) must be disposed of in accordance with current laws.
- ▶ The air conditioner contains a refrigerant that has to be disposed of as special waste. At the end of its life cycle, the air conditioner must be disposed of in authorized centers or returned to the retailer so that it can be disposed of correctly and safely.

Safety precautions

Installing the unit

IMPORTANT : When installing the unit, always remember to connect first the refrigerant tubes, then the electrical lines.

Always disassemble the electric lines before the refrigerant tubes.

- ▶ Upon receipt, inspect the product to verify that it has not been damaged during transport. If the product appears damaged, DO NOT INSTALL it and immediately report the damage to the carrier or retailer (if the installer or the authorized technician has collected the material from the retailer).
- ▶ After completing the installation, always carry out a functional test and provide the instructions on how to operate the air conditioner to the user.
- ▶ Do not use the air conditioner in environments with hazardous substances or close to equipment that release free flames to avoid the occurrence of fires, explosions or injuries.
- ▶ The air conditioner should be used only for the applications for which it has been designed: the indoor unit is not suitable to be installed in areas used for laundry.
- ▶ Our units must be installed in compliance with the spaces indicated in the installation manual to ensure either accessibility from both sides or ability to perform routine maintenance and repairs. The units' components must be accessible and that can be disassembled in conditions of complete safety either for people or things.

For this reason, where it is not observed as indicated into the Installation Manual, the cost necessary to reach and repair the unit (in safety, as required by current regulations in force) with slings, trucks, scaffolding or any other means of elevation won't be considered in-warranty and charged to end user.

Power supply line, fuse or circuit breaker

- ▶ Always make sure that the power supply is compliant with current safety standards. Always install the air conditioner in compliance with current local safety standards.
- ▶ Always verify that a suitable grounding connection is available.
- ▶ Verify that the voltage and frequency of the power supply comply with the specifications and that the installed power is sufficient to ensure the operation of any other domestic appliance connected to the same electric lines.
- ▶ Always verify that the cut-off and protection switches are suitably dimensioned.
- ▶ Verify that the air conditioner is connected to the power supply in accordance with the instructions provided in the wiring diagram included in the manual.
- ▶ Always verify that electric connections (cable entry, section of leads, protections...) are compliant with the electric specifications and with the instructions provided in the wiring scheme. Always verify that all connections comply with the standards applicable to the installation of air conditioners.
- ▶ Be sure not to perform power cable modification, extension wiring, and multiple wire connection.
 - It may cause electric shock or fire due to poor connection, poor insulation, or current limit override.
 - When extension wiring is required due to power line damage, refer to "How to connect your extended power cables" in the installation manual.



- Make sure that you earth the cables.
 - Do not connect the earth wire to the gas pipe, water pipe, lighting rod or telephone wire. If earthing is not complete, electric shock or fire may occur.
- Install the circuit breaker.
 - If the circuit breaker is not installed, electric shock or fire may occur.
- Make sure that the condensed water dripping from the drain hose runs out properly and safely.
- Install the power cable and communication cable of the indoor and outdoor unit at least 1 m away from the electric appliance.
- Install the indoor unit away from lighting apparatus using the ballast.
 - If you use the wireless remote controller, reception error may occur due to the ballast of the lighting apparatus.
- Do not install the air conditioner in following places.
 - Place where there is mineral oil or arsenic acid. Resin parts flame and the accessories may drop or water may leak. The capacity of the heat exchanger may reduce or the air conditioner may be out of order.
 - The place where corrosive gas such as sulfurous acid gas generates from the vent pipe or air outlet. The copper pipe or connection pipe may corrode and refrigerant may leak.
 - The place where there is a machine that generates electromagnetic waves. The air conditioner may not operate normally due to control system.
 - The place where there is a danger of existing combustible gas, carbon fiber or flammable dust. The place where thinner or gasoline is handled. Gas may leak and it may cause fire.

Required tools for installation

General tools





- ① Vacuum pump
- ② Torque wrench
- ③ Pipe cutter
- ④ Reamer
- ⑤ Pipe bender
- ⑥ Level
- ⑦ Screw driver
- ⑧ Spanner
- ⑨ Drill
- ⑩ L wrench
- ⑪ Measuring tape

Tools for trial operation

- ① Thermometer
- ② Insulation resistance tester
- ③ Voltage detector

Accessories

Before installing the product, check the following accessories are included with your air conditioner.

<p>Refrigerant pipe insulator</p> 	<p>Cable tie</p> 	<p>User's manual</p> 	<p>Installation manual</p> 
---	--	--	--

Selecting a location for installation

- ▶ Select a location for installation that satisfies the following conditions and customer demands.
 1. A place where air can be well distributed.
 2. A place where air can pass through without any interference.
 3. A place where condensed water can be well drained.
 4. A place where maintenance of the product can be carried out without inconvenience.
 5. A place where enough length of pipe (within the allowable length) can be installed between the indoor unit and outdoor unit.
 6. The product should be installed on even and sturdy floor.
 7. The product should not be installed in a humid place such as entrance door or kitchen.
 8. The product should not be exposed to the sunlight. (If necessary, place a sunshade for the product.)
 - Otherwise, the surface of the product may discolor due to the direct sunlight.

Required space for product installation

- ▶ To use the installation space efficiently, refer to the 'Corner installation' as shown below.

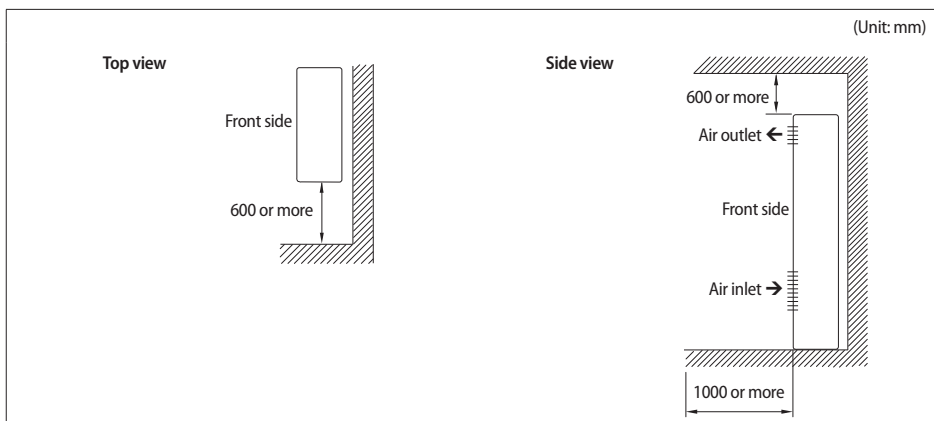

Installing an indoor unit

Stand type

1. The indoor unit should be installed in a place where there is no obstacle around the product, where pipe or electric work can be conveniently carried out and where the indoor unit cannot be shaken or fall by vibration or external shock.
2. The hole for pipe connection on the wall should be drilled at the height of 150~200 mm or lower and it needs to slope slightly downward. (Refer to the table below.)
 - If the height of the hole for pipe connection is 200 mm or higher, the indoor unit drain hose should be installed through the hole for drain hose(Ø35 mm) which is above the hole for pipe connection.

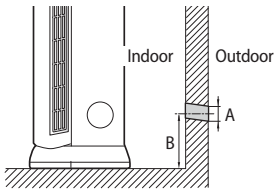

Model	Diameter (A)	Height(B)
AM280RNPDKH	90 mm	150 mm or less

3. Select the pipe direction and drill a hole on the cover of the indoor unit by knocking the cover with a hand or tool.
 - Pipe can be installed on left, right, or rear side of the indoor unit.

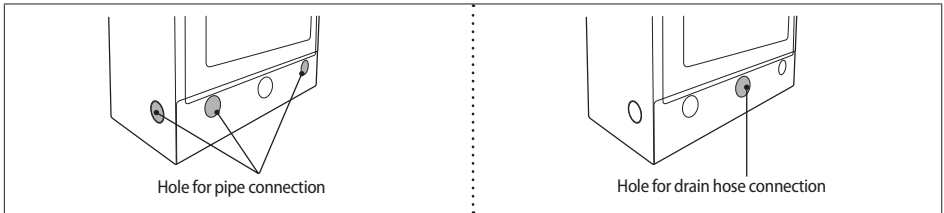

4. For AM280RNPDKH model
 - After detaching the front air inlet of the indoor unit, loosen the 4 bolts at the bottom of the product to remove the wooden supports.

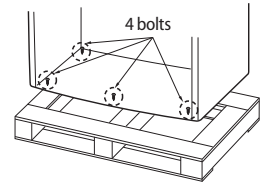

Connecting a refrigerant pipe

The indoor unit is connected to a liquid pipe, gas pipe and drain pipe. The inside of the refrigerant pipe should be cleaned.

1. Purging the pipe

- ▶ The indoor unit is packed with nitrogen gas to protect the product in delivery. Remove the stopper of the pipe and purge the pipes.



- Do not remove the stopper until you are ready to work on the pipe connection to prevent foreign substance from entering the pipe.

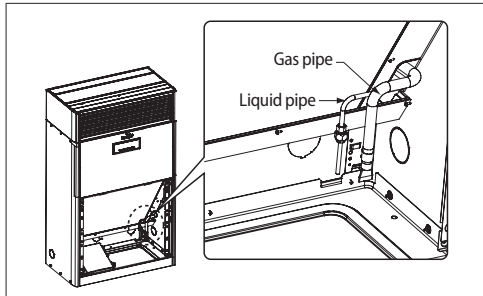

2. Connecting the pipe

- ▶ Place the pipes to each liquid and gas pipe of the indoor unit and turn the nuts of flaring part by hand, then tighten the nuts by using a torque wrench. When tightening the nuts, correct torque should be applied depending on the pipe size.
- ▶ When cutting the pipes, refer to the 'Cutting or flaring a pipe' section.
- ▶ For wall mounted type, the pipe can be installed on left, right, bottom and rear side of the indoor unit.
- * Correct tightening torque should be applied depending on the diameter of the pipe. Tighten the nuts firmly to prevent any refrigerant leak.

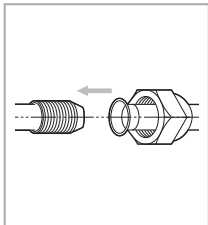

Outer diameter (D, mm)	Torque (N·m)	Flaring (L, mm)	Flaring shape
6.35	14~18	8.7~9.1	
9.52	34~42	12.8~13.2	
12.70	49~61	16.2~16.6	
15.88	68~82	19.3~19.7	

* 1 N·m = 10 kgf·cm



- When brazing work is required for the pipe, nitrogen blowing work should be carried out.
- Apply the refrigerating oil on the surface of the flaring part to prevent refrigerant gas leak.
- When bending the connection pipe, make sure that the pipe does not have any cracks or twists.
- When the refrigerant pipe is not correctly connected and the compressor is operating with the service valve opened, the refrigerant pipe intakes air and creates high pressure inside the refrigerant cycle, which causes explosion or injury.

Cutting or flaring a pipe

1. Check that all the required tools are prepared.
 - ▶ Pipe cutter, flaring tool, reamer, die, etc.
2. Use the pipe cutter to cut the pipe and make sure that the cut edge remains at 90° angle with the edge of the pipe.
 - ▶ When cutting the pipe, make sure that the cut edge is not oblique, rough, or burred.

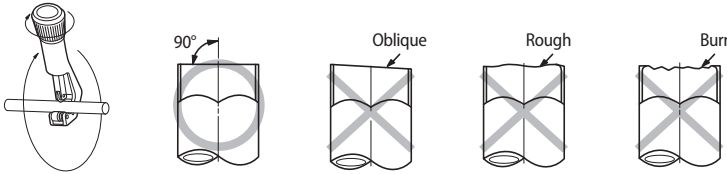

3. To prevent a gas leak, remove all burrs at the cut edge of the pipe using a reamer or trim the rough part with a pipe cutting tool.
4. Carry out the flaring work with a flaring tool.

[Flaring tools]

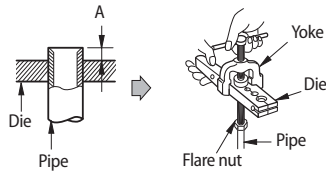
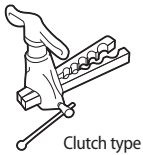

	Pipe diameter (D, mm)	Depth of flaring part (A, mm)		
		Using flaring tool for R-410A	Using conventional flaring tool	
			Clutch type	Wing nut type
	6.35	0 ~ 0.5	1.0 ~ 1.5	1.5 ~ 2.0
	9.52	0 ~ 0.5	1.0 ~ 1.5	1.5 ~ 2.0
	12.70	0 ~ 0.5	1.0 ~ 1.5	1.5 ~ 2.0
	15.88	0 ~ 0.5	1.0 ~ 1.5	1.5 ~ 2.0

5. Check that the flaring shape is correct.
 - ▶ When carrying out the flaring work, make sure the flaring part is not inclined, damaged, cracked or uneven.

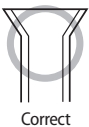

Leak test and insulation

Testing gas leak

- ▶ Use the nitrogen gas to test refrigerant gas leak of liquid and gas pipe connection part.
For detailed information on the leak test, refer to the installation manual of an outdoor unit.

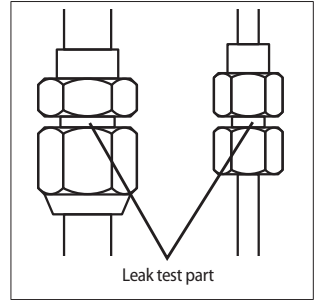

Insulating the pipe

After carrying out the gas leak test, insulate the refrigerant pipe.

1. Selecting an insulator of the refrigerant pipe
 - ▶ Insulate both the liquid and gas pipe while considering the thickness of the insulator depending on each pipe size.
 - ▶ Indoor temperature 30 °C and humidity below 85 % are the standard condition. If the insulator is used in high humidity condition, use one grade thicker insulator by referring to the table below.

Pipe	Pipe size (mm)	Insulation type [Heating/Cooling(mm)]		Remarks
		Standard [30 °C, 85 %]	High humidity [30 °C, over 85 %]	
EPDM, NBR				
Liquid pipe	6.35 ~ 9.52	9 t	9 t	Heat resistant temperature is 120 °C or more
	12.70 ~ 50.80	13 t	13 t	
Gas pipe	6.35	13 t	19 t	
	9.52 ~ 25.40	19 t	25 t	
	28.58 ~ 44.45		32 t	
	50.80	25 t	38 t	

- ▶ When installing the insulator in places and conditions as below, use the same insulator that is used in high humidity conditions.
 - <Geographic condition>
 - High humidity places such as near shoreline, hot spring, lake or river, and ridge (when the part of the building is covered by earth and sand.)
 - <Operation condition>
 - Restaurant ceiling, sauna, swimming pool etc.
 - <Building construction condition>
 - The ceiling which is frequently exposed to moisture, and where cooling is not provided (The pipe installed at a corridor of a dormitory and studio or near an exit that opens and closes frequently.)
 - The place where the pipe is installed is highly humid due to the lack of ventilation system.

Leak test and insulation

2. Insulate the refrigerant pipe.

- ▶ If the pipe is not insulated correctly, condensed water may form on the surface of the pipe or product capacity may decrease.
- ▶ Check that the curved part of the pipe is firmly covered by the insulator.

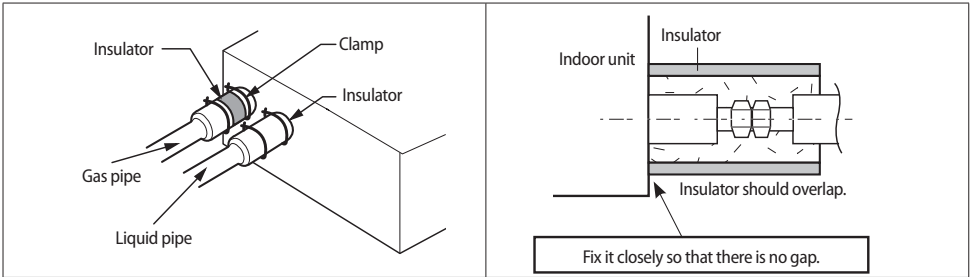

Single pipe system

- ▶ The gas pipe and liquid pipe can be attached together but make sure that they are not excessively pressed each other.
- ▶ When the gas pipe and liquid pipe are attached together, use 1 grade thicker insulator.

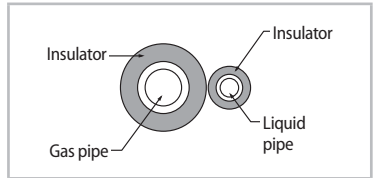

Single pipe system after distribution kit

- ▶ When installing the gas pipe and the liquid pipe, allow 10 mm of space between the pipes.
- ▶ When the gas pipe and liquid pipe are attached together, use 1 grade thicker insulator.

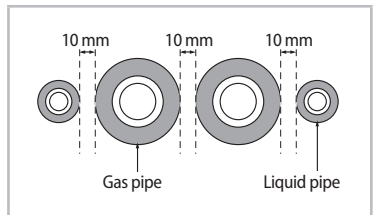

- The insulator of the pipe should not be disconnected or cracked. Apply adhesives on the connection part of the insulator to prevent it from getting damp.
- Cover the insulator of the refrigerant pipe with a sealing tape if the insulator can be exposed to sunlight. (Make sure that the thickness of the insulator is not decreased by the sealing tape.)
- When insulating the pipe, make sure that the thickness of insulator on the curved part or on the part contacted with the pipe hanger is not decreased.
- When the thickness of the insulator is decreased, increase the thickness of the insulator by using additional insulator.

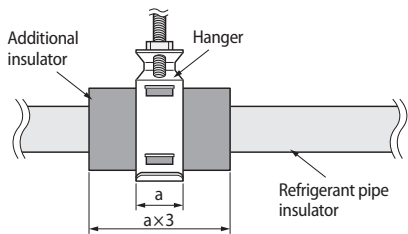

Installing a drain pipe

1. Depending on the height of the hole on the wall, install the drain pipe as shown below.

▶ When the height of the hole for pipe on the wall is lower than the hole for pipe of the indoor unit

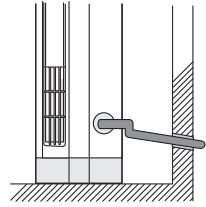

▶ When the height of the hole for pipe on the wall is higher than the hole for pipe of the indoor unit

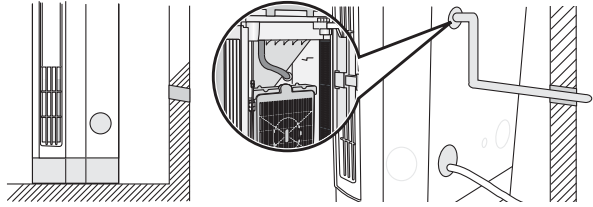

2. When the drain hose installation is completed, pour water to check that the water is well drained.

3. When passing the pipe through the wall, be careful not to make the situations as shown below.

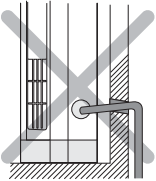
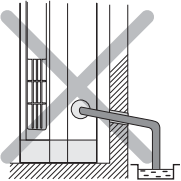
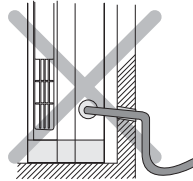
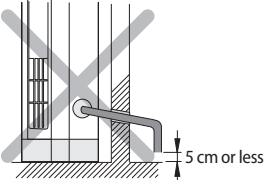
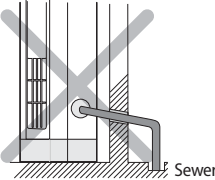
 <ul style="list-style-type: none">• Hole on the wall is higher.	 <ul style="list-style-type: none">• Tip of the hose is immersed in the water.	 <ul style="list-style-type: none">• Pipe is bent.
 <ul style="list-style-type: none">• Gap between the pipe and the ground is close.	 <ul style="list-style-type: none">• Tip of the hose is within the sewer.	

Connecting a drain hose

1. After connecting the drain hose to the connection part of the drain board, fix the drain hose with tape or cable tie.
2. Cover the drain hose closely with the insulator to prevent water leak.

Pipe material	PVC pipe (ø 25)
Insulator	Foamed polyethylene

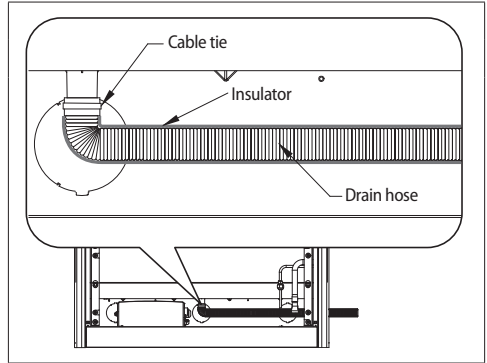

Leak test

1. Pour water into the drain board or drain test hole of the indoor unit.
2. Check that water is well drained at the end of the drain pipe.
3. If water leaks, check that the indoor unit is installed on level ground and connection of drain hose and drain pipe is correct. If not, proper action should be taken.



- After connecting the drain pipe to the indoor unit, drainage test should be carried out. If the leak test is not carried out correctly, water may enter the indoor area, which may cause property damage.
- When pouring water into the drain board or drain test hole, the water should not overflow.
- The leak test should be carried out at least for at least 24 hours.

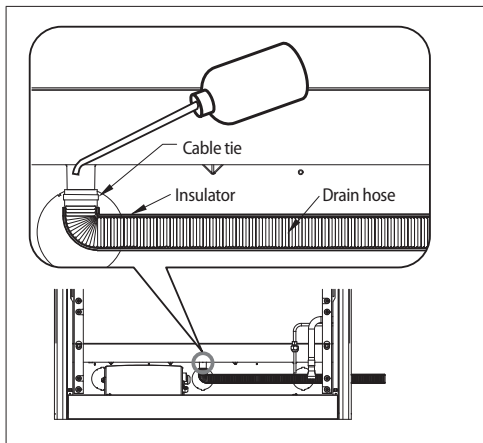

Wiring work

Connecting a power cable and communication cable

- ▶ Disconnect the power supply before the wiring work.
- ▶ The power cable and communication cable between indoor units should be within 10 % of the maximum allowable length of the cable or voltage drop.
- ▶ Install the circuit breaker(ELCB, MCCB, ELB) that can cover the number of connected indoor units.
- ▶ Connect the F3 and F4 (the wire connected with COM2:CN33) of the indoor unit to the communication cable of the wired remote controller.
- ▶ Connect all the wires firmly by using a correct tool and tighten them by applying correct torque so that the cables can withstand external force. Arrange the cables correctly to prevent the cover or other parts from loosening. If the cable is connected loosely, overheat, electric shock or fire may occur.

Torque (N·m)	
M4	1.2~1.8

- ▶ Install the power and communication cable in a protection tube to protect them from water or external shock.
- ▶ Connect the power cable to ELCB or MCCB and ELB.
- ▶ Between the power cable and communication cable, 50 mm or more space should be maintained.

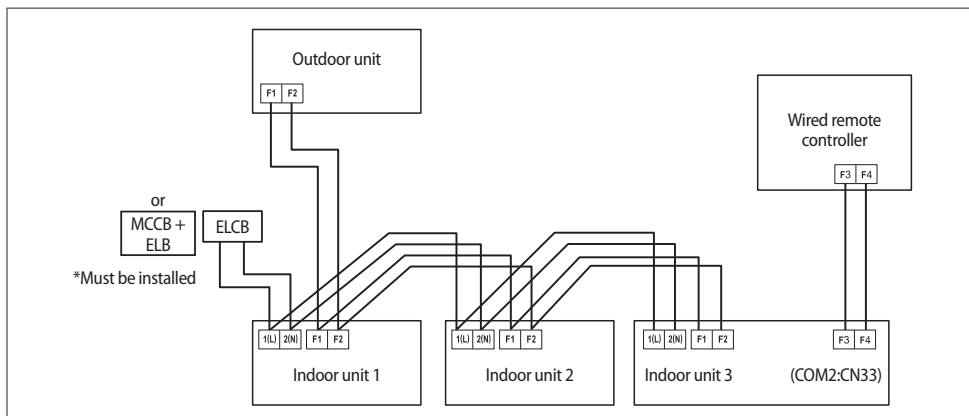

- The circuit diagram on the cables as shown above represents only outline, so it does not describe detailed instruction on the actual installation work.
- Basically, power supply for an indoor unit is separated from power supply for an outdoor unit.
- The communication cable should not branch due to possible communication error.
- The power cable for terminal block should not branch from 1 indoor unit to 2 indoor units.
- When peeling off outer sheath of the power cable, be careful not to damage the inner sheath of the cable by using a correct tool.
- More than 20 mm of power cable or communication cable of the indoor unit should be inside the electric box.
- The installation of communication cable should be separated from power cable or other communication cables.
- The connection cables between indoor units and outdoor units should not be too tight.

Wiring work

Selecting a solderless ring terminal

- ▶ Select the solderless ring terminal depending on the nominal dimension of the power cable.
- ▶ Cover and insulate the solderless ring terminal and connection part of the power cable.

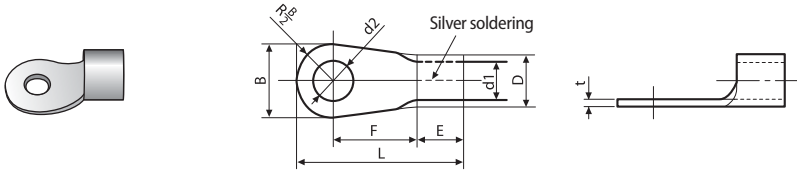

Nominal dimension for a cable (mm ²)		1.5		2.5		4
Nominal dimension for a screw (mm)		4	4	4	4	4
B	Standard dimension (mm)	6.6	8	6.6	8.5	9.5
	Allowance (mm)	±0.2		±0.2		±0.2
D	Standard dimension (mm)	3.4		4.2		5.6
	Allowance (mm)	+0.3 -0.2		+0.3 -0.2		+0.3 -0.2
d1	Standard dimension (mm)	1.7		2.3		3.4
	Allowance (mm)	±0.2		±0.2		±0.2
E	Min. (mm)	4.1		6		6
F	Min. (mm)	6		6		5
L	Max. (mm)	16		17.5		20
d2	Standard dimension (mm)	4.3		4.3		4.3
	Allowance (mm)	+0.2		+0.2		+0.2
t	Min. (mm)	0.7		0.8		0.9

Specification of electric cables between indoor units

Power supply (1 phase)	MCCB	ELB	Power cable	Ground wire	Communication cable
220 - 240 V~ / 50 Hz Max. : 253 V Min. : 187 V	X A	X A, 30 mA 0.1 s	2.5 mm ²	2.5 mm ²	0.75 ~ 1.5 mm ²

- * Select the power cable by referring to the formula 2 below.
- * Power Supply cords of parts of appliances for outdoor use shall not be lighter than polychloroprene sheathed flexible cord. (Code designation IEC:60245 IEC 57 / CENELEC: H05RN-F or IEC:60245 IEC 66 / CENELEC: H07RN-F)

1. Select the capacity of ELB and MCCB by referring to the formula below.

$$\text{The capacity of ELB, MCCB } X[A] = 1.25 \times 1.1 \times \sum A_i$$

- * X : The capacity of ELB, MCCB
- * $\sum A_i$: Sum of rated currents of each indoor unit.

- * Rated current

Model	Rated current (A)
AM280RNPDKH	4.73

2. When selecting the thickness of cable or length of cable, make sure that the sum of voltage drop between indoor units is 10 % or less of input power (220 - 240 V).

$$\sum_{k=1}^n \left(\frac{\text{Coef} \times 35.6 \times L_k \times i_k}{1000 \times A_k} \right) < 10 \% \text{ of input voltage}[V]$$

- * Coef: Use about 1.55 in consideration of contact resistance when tightening the terminal of a wire.
- * L_k : Distance between indoor units [m], A_k : Thickness of a wire (mm²)
- i_k : Electric current between indoor units[A]

Wiring work

Example of Installation

- ▶ Selecting the thickness of wire when Total length of power cable $L = 100$ (m), Initial input current $i = 10$ [A], Electric current consumption for each indoor unit 1 [A], and total number of indoor unit installation 10.

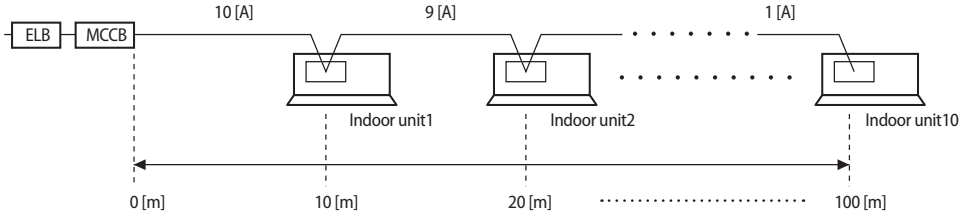

- ▶ Apply following formula.

$$\sum_{k=1}^n \left(\frac{\text{Coef} \times 35.6 \times L_k \times i_k}{1000 \times A_k} \right) < 10\% \text{ of input voltage [V]}$$

* Calculation

- Installing with 1 sort of wire.

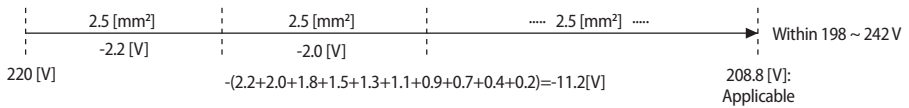



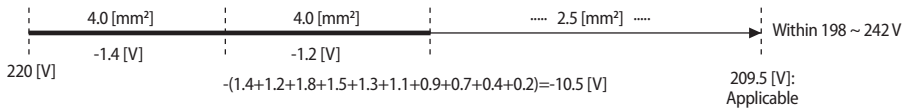

- Installing with 2 sorts of wires.



How to connect your extended power cables

1. Prepare the following tools.

Tools	Crimping pliers	Connection sleeve (mm)	Insulation tape	Contraction tube (mm)
Spec	MH-14	20xØ6.5(HxOD)	Width 19mm	70xØ8.0(LxOD)
Shape				

2. As shown in the figure, peel off the shields from the rubber or wire of the power cable.

- Peel off 20 mm of cable shields from the pre-installed tube.



- For information about the power cable specifications for indoor and outdoor units, refer to the installation manual.
- After peeling off cable wires from the pre-installed tube, insert a contraction tube.

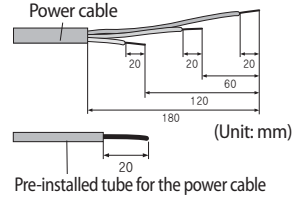

3. Insert both sides of core wire of the power cable into the connection sleeve.

► Method 1

- Push the core wire into the sleeve from both sides.

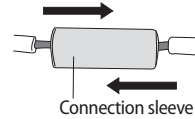

► Method 2

- Twist the wire cores together and push it into the sleeve.

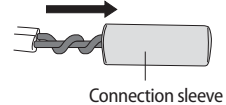

4. Using a crimping tool, compress the two points and flip it over and compress another two points in the same location.

- The compression dimension should be 8.0.
- After compressing it, pull both sides of the wire to make sure it is firmly pressed.

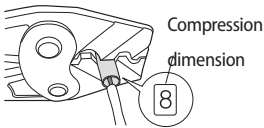

► Method 1

Compress it 4 times.

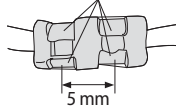

► Method 2

Compress it 4 times.

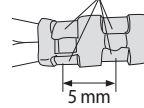

Wiring work

5. Wrap it with the insulation tape twice or more and position your contraction tube in the middle of the insulation tape. Three or more layers of insulation are required.

► Method 1

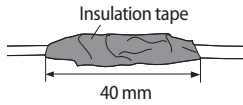

► Method 2

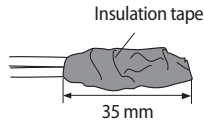

6. Apply heat to the contraction tube to contract it.

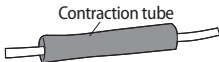

7. After tube contraction work is completed, wrap it with the insulation tape to finish.

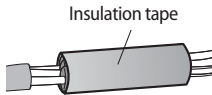

CAUTION

- Make sure that the connection parts are not exposed to outside.
- Be sure to use insulation tape and a contraction tube made of approved reinforced insulating materials that have the same level of withstand voltage with the power cable. (Comply with the local regulations on extensions.)



WARNING

- In case of extending the electric wire, please DO NOT use a round-shaped Pressing socket.
- Incomplete wire connections can cause electric shock or a fire.

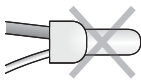

Setting an indoor unit address and installation option

Set the indoor unit address and installation option with remote controller option.

Set the each option separately since you cannot set the ADDRESS setting and indoor unit installation setting option at the same time. You need to set twice when setting indoor unit address and installation option.

Procedure of option setting

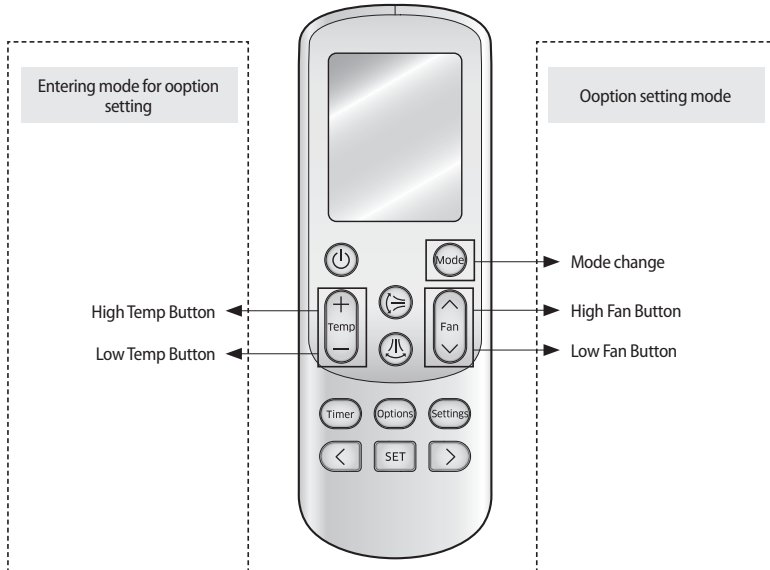

Step 1. Entering setting mode

1. Remove batteries from the remote controller.
2. While pressing and holding the Temp + and Temp - buttons, insert the batteries.
3. Check if you have entered the option setting stage.

Step 2. Procedure of option setting











































After entering the option setting stage, select the option as shown below.



- 24 digits are available to be input for the option setting.
- SEG1, SEG7, SEG13, and SEG19 are page option so they do not need to be set.
- Set the SEG2~SEG6, SEG8~SEG12 in 'ON' status and SEG14~18, SEG20~24 in 'OFF' status.

SEG1	SEG2	SEG3	SEG4	SEG5	SEG6	SEG7	SEG8	SEG9	SEG10	SEG11	SEG12	On(SEG1~12)	Off(SEG13~24)
0	X	X	X	X	X	1	X	X	X	X	X	on 00 Auto	off 00 Auto
SEG13	SEG14	SEG15	SEG16	SEG17	SEG18	SEG19	SEG20	SEG21	SEG22	SEG23	SEG24		
2	X	X	X	X	X	3	X	X	X	X	X		

Setting an indoor unit address and installation option

Option setting	Status
<p>1. Setting SEG2, SEG3 option</p> <p>Press Low Fan button(V) to enter SEG2 value.</p> <p>Press High Fan button(^) to enter SEG3 value.</p> <p>Each time you press the button,  →  → ...  →  will be selected in rotation.</p>	  SEG2 SEG3
<p>2. Setting Cool mode</p> <p>Press Mode button to change to Cool mode in the ON status.</p>	
<p>3. Setting SEG4, SEG5 option</p> <p>Press Low Fan button(V) to enter SEG4 value.</p> <p>Press High Fan button(^) to enter SEG5 value.</p> <p>Each time you press the button,  →  → ...  →  will be selected in rotation.</p>	  SEG4 SEG5
<p>4. Setting Dry mode</p> <p>Press Mode button to change to DRY mode in the ON status.</p>	
<p>5. Setting SEG6, SEG8 option</p> <p>Press Low Fan button(V) to enter SEG6 value.</p> <p>Press High Fan button(^) to enter SEG8 value.</p> <p>Each time you press the button,  →  → ...  →  will be selected in rotation.</p>	  SEG6 SEG8
<p>6. Setting Fan mode</p> <p>Press Mode button to change to FAN mode in the ON status.</p>	
<p>7. Setting SEG9, SEG10 option</p> <p>Press Low Fan button(V) to enter SEG9 value.</p> <p>Press High Fan button(^) to enter SEG10 value.</p> <p>Each time you press the button,  →  → ...  →  will be selected in rotation.</p>	  SEG9 SEG10
<p>8. Setting Heat mode</p> <p>Press Mode button to change to HEAT mode in the ON status.</p>	
<p>9. Setting SEG11, SEG12 option</p> <p>Press Low Fan button(V) to enter SEG11 value.</p> <p>Press High Fan button(^) to enter SEG12 value.</p> <p>Each time you press the button,  →  → ...  →  will be selected in rotation.</p>	  SEG11 SEG12
<p>10. Setting Auto mode</p> <p>Press Mode button to change to AUTO mode in the OFF status.</p>	
<p>11. Setting SEG14, SEG15 option</p> <p>Press Low Fan button(V) to enter SEG14 value.</p> <p>Press High Fan button(^) to enter SEG15 value.</p> <p>Each time you press the button,  →  → ...  →  will be selected in rotation.</p>	  SEG14 SEG15
<p>12. Setting Cool mode</p> <p>Press Mode button to change to Cool mode in the OFF status.</p>	

Option setting	Status
13. Setting SEG16, SEG17 option Press Low Fan button(V) to enter SEG16 value. Press High Fan button(^) to enter SEG17 value. Each time you press the button, → → ... → will be selected in rotation.	 SEG16 SEG17
14. Setting Dry mode Press Mode button to change to Dry mode in the OFF status.	 Dry
15. Setting SEG18, SEG20 option Press Low Fan button(V) to enter SEG18 value. Press High Fan button(^) to enter SEG20 value. Each time you press the button, → → ... → will be selected in rotation.	 SEG18 SEG20
16. Setting Fan mode Press Mode button to change to Fan mode in the OFF status.	 Fan
17. Setting SEG21, SEG22 option Press Low Fan button(V) to enter SEG21 value. Press High Fan button(^) to enter SEG22 value. Each time you press the button, → → ... → will be selected in rotation.	 SEG21 SEG22
18. Setting Heat mode Press Mode button to change to HEAT mode in the OFF status.	 Heat
19. Setting SEG23, SEG24 mode Press Low Fan button(V) to enter SEG23 value. Press High Fan button(^) to enter SEG24 value. Each time you press the button, → → ... → will be selected in rotation.	 SEG23 SEG24

Step 3. Checking the option you have set

After option setting is completed, press the Mode button to check whether the setting value you have input is correct or not.

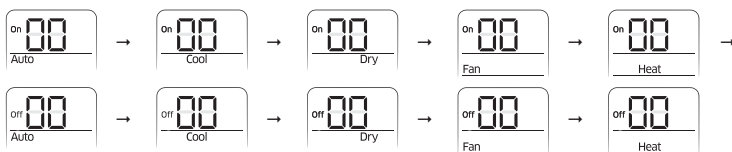

Step 4. Inputting an option

Press the button while aiming the remote controller towards the indoor unit to complete the setting. For the correct option setting, you must input the option twice.

Step 5. Checking operation

1. Reset the indoor unit by pressing the RESET button of indoor unit or outdoor unit.
2. Take the batteries out of the remote controller and insert them again and then press the button.

Setting an indoor unit address and installation option

Setting an indoor unit address (MAIN/RMC)

- Check whether power is supplied to the indoor unit or not.
 - When power is not supplied to the indoor unit, there should be additional source of power supply to the indoor unit.
- The panel(display) should be connected to the indoor unit to receive option.
- Depending on the installation condition of the air conditioner, each indoor unit address (MAIN/RMC) should be set.
- Set the indoor unit address(MAIN/RMC) by using a remote controller.
 - The default setting value of the indoor unit address (MAIN/RMC) is "0A0000-100000-200000-300000".

Option No. : 0AXXXX-1XXXXX-2XXXXX-3XXXXX

Option	SEG1	SEG2	SEG3	SEG4	SEG5	SEG6						
Explanation	PAGE	MODE	Setting Main address	Hundreds digit of indoor unit address	Tens digit of indoor unit address	Unit digit of indoor unit address						
Remote Controller Display	-											
Indication and Details	Indication	Details	Indication	Details	Indication	Details	Indication	Details	Indication	Details	Indication	Details
	0	A	0	No Main address	0~9	Hundreds digit	0~9	Tens digit	0~9	Unit digit		
			1	Main address setting mode								
Option	SEG7	SEG8	SEG9	SEG10	SEG11	SEG12						
Explanation	PAGE		Setting RMC address		Group channel(*16)	Group address						
Remote Controller Display	-											
Indication and Details	Indication	Details	Indication	Details	Indication	Details	Indication	Details				
	1		0	No RMC address			RMC1	0~F	RMC2	0~F		
			1	RMC address setting mode								



- When "A"~"F" is input to SEG5~6, the indoor unit main address is not changed.
- If you set the SEG 3 as 0, the indoor unit will maintain the existing main address even if you input the option value of SEG5~6.
- If you set the SEG 9 as 0, the indoor unit will maintain existing RMC address even if you input the option value of SEG11~12.
- You cannot set SEG11 and SEG12 as F value at the same time.

Setting an indoor unit installation option (suitable for the condition of each installation location)

1. Check whether power is supplied or not.
 - When power is not supplied to the indoor unit, there should be additional source of power supply to the indoor unit.
2. The panel(display) should be connected to an indoor unit to receive option.
3. Depending on the installation condition, set the installation option of the indoor unit.
 - The default setting value of the indoor unit installation option is "020010-100000-200000-300000".
 - Individual control setting (SEG20) is the function that controls an indoor unit individually when there is more than one indoor unit.
4. Set the indoor unit option by using a remote controller.

02 series installation option





SEG1	SEG2	SEG3	SEG4	SEG5	SEG6
0	2	-	External room temperature sensor / Minimizing fan operation when thermostat is off	Central control	FAN RPM compensation
SEG7	SEG8	SEG9	SEG10	SEG11	SEG12
1	-	-	-	EEV Step when heating stops	-
SEG13	SEG14	SEG15	SEG16	SEG17	SEG18
2	External control	External control output / External heater On or Off signal	-	Buzzer	-
SEG19	SEG20	SEG21	SEG22	SEG23	SEG24
3	Individual control of a remote controller	Heating setting compensation / Removing condensated water in heating mode	Oil return / EEV opening step in defrost mode	-	-

- ▶ When setting the option other than above SEG values, the option will be set as "0".
- ▶ SEG5 central control option is basically set as 1(Use), so you don't need to set the central control option additionally to use the central control function. However, if the central control is not connected but it doesn't indicate an error message or if the indoor unit needs to be excluded from the central control, you need to set the central control option as 0 (Disuse).
- ▶ The external output of SEG15 is generated by MIM-B14 connection. (Refer to the manual of MIM-B14.)



Setting an indoor unit address and installation option

02 series installation option(Detailed)

Option No. : 02XXXX-1XXXXX-2XXXXX-3XXXXX

Option	SEG1		SEG2		SEG3		SEG4			SEG5		SEG6			
Explanation	Page		Mode		-		Use of external room temperature sensor / Minimizing fan operation when thermostat is off			Use of central control		FAN RPM compensation			
Remote controller display	-				-										
Indication and Details	Indication	Details	Indication	Details	Indication	Details	Indication	Details		Indication	Details	Indication	Details		
								Use of External room temperature sensor	Minimizing fan operation when thermostat is off						
	0		2		-		0	Disuse	Disuse	1	Use	0	Disuse	0	Disuse
							1	Use	Disuse			1	-		
							2	Disuse	Use ^(*)			2	-		
3							Use	Use ^(*)	3			-			
										4	RPM compensation				

Option	SEG7		SEG8		SEG9		SEG10		SEG11			SEG12	
Explanation	Page		-		-		-		EEV opening step when heating stops			-	
Remote controller display	-		-		-		-					-	
Indication and Details	Indication	Details	Indication	Details	Indication	Details	Indication	Details	Indication	Details		Indication	Details
									0	Default value			
	1	-		-	-	1	Noise decreasing setting		-				

Option	SEG13		SEG14		SEG15			SEG16		SEG17		SEG18				
Explanation	Page		Use of external control		Setting the output of external control / External heater On/Off signal			-		Buzzer control		-				
Remote controller display	-							-				-				
Indication and Details	Indication	Details	Indication	Details	Indication	Details		Indication	Details	Indication	Details	Indication	Details			
						Setting the output of external control	External heater On/Off signal									
	2		0		Disuse		0	Thermo on	-	-	1	Disuse buzzer	-			
							1	ON/OFF control	1						Operation ON	-
							2	OFF control	2						-	Use ^(*)
3							Window ON/OFF control	3	-						Use ^(*)	

Option	SEG19	SEG20	SEG21			SEG22	SEG23	SEG24				
Explanation	Page	Individual control of a remote controller	Heating setting compensation / Removing condensated water in heating mode			Oil return / EEV opening step in defrost mode	-	-				
Remote controller display	-						-	-				
Indication and Details	Indication	Details	Indication	Details	Indication	Details		Indication	Details	Indication	Details	
	3		0 or 1	Channel 1	0	Default ^{(*)3}	Disuse	0	Default value	1	Oil return or noise decreasing in defrost mode	-
		1		1	2 °C	Disuse						
		2	Channel 2	2	5 °C	Disuse						
		3	Channel 3	3	Default ^{(*)3}	Use ^{(*)4}						
		4	Channel 4	4	2 °C	Use ^{(*)4}						
				5	5 °C	Use ^{(*)4}						

^{(*)1} Minimizing fan operation when thermostat is off

- Fan operates for 20 seconds at an interval of 5 minutes in heat mode.

^{(*)2} When the following 2 or 3 is used as external heater On/Off signal, the signal for monitoring external contact control will not be output.

2: Fan is turned on continually when the external heater is turned on,

3: Fan is turned off when the external heater is turned on with cooling only indoor unit

Cooling only indoor unit: To use this option, install the Mode Select switch (MCM-C200) on the outdoor unit and fix it as cool mode.

* If Fan is set to off for cooling only indoor unit by setting the SEG9=3 or SEG15=3, you need to use an external sensor or wired remote controller sensor to detect indoor temperature exactly.

^{(*)3} Default setting value

- 4Way Cassette, Mini 4Way Cassette: 5 °C
- Other indoor units: 2 °C

^{(*)4} This function can be applied to 4 Way Cassette and Mini 4 Way Cassette only. If the air conditioner operates the heating mode immediately after finishing the cooling mode, the condensated water in the drain pan becomes water vapor by the heat of the indoor unit heat exchanger. Since the water vapor might be condensed on the indoor unit, which may fall into a living space, use this function to get rid of the water vapor out of the indoor unit by operating the fan (for maximum 20 minutes) even when the indoor unit is turned off after cooling mode is turned to heating mode.

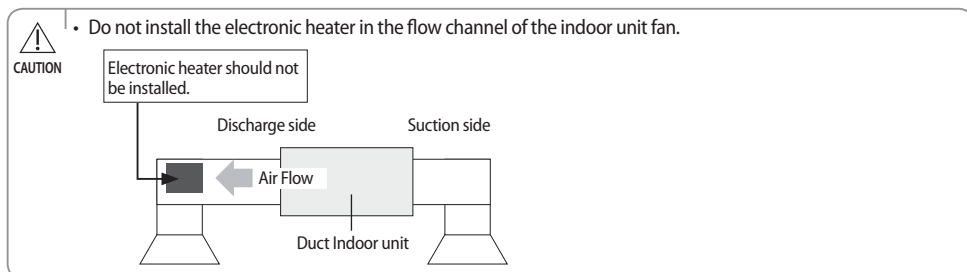

Setting an indoor unit address and installation option









Setting an indoor unit address and installation option

05 series installation option

SEG1	SEG2	SEG3	SEG4	SEG5	SEG6
0	5	Use of AutoChangeOver for HR only in Auto mode	(When setting SEG3) Standard heating temp. Offset	(When setting SEG3) Standard cooling temp. Offset	(When setting SEG3) Standard for mode change Heating → Cooling
SEG7	SEG8	SEG9	SEG10	SEG11	SEG12
1	(When setting SEG3) Standard for mode change Cooling → Heating	(When setting SEG3) Required time for mode change	Long pipe or compensation option for height difference between indoor units	MTFC	-
SEG13	SEG14	SEG15	SEG16	SEG17	SEG18
2	-	-	-	-	Control variables when using hot water / external heater
SEG19	SEG20	SEG21	SEG22	SEG23	SEG24
3	-	-	-	-	-

05 series installation option(Detailed)

Option No. : 05XXXX-1XXXaXX-2XXXXX-3XXXXX

Option	SEG1		SEG2		SEG3		SEG4		SEG5		SEG6		
Explanation	PAGE		MODE		Use of AutoChangeOver for HR only in Auto mode		(When setting SEG3) Standard heating temp. Offset		(When setting SEG3) Standard cooling temp. Offset		(When setting SEG3) Standard for mode change Heating → Cooling		
Remote Controller Display	-												
Indication and Details	Indication	Details	Indication	Details	Indication	Details	Indication	Details	Indication	Details	Indication	Details	
	0		5		0	Follow product option	0	0	0	0	0	0	1
					1	Use Auto Change Over for HR only	1	0.5	1	0.5	1	1.5	
							2	1	2	1	2	2	
							3	1.5	3	1.5	3	2.5	
							4	2	4	2	4	3	
							5	2.5	5	2.5	5	3.5	
							6	3	6	3	6	4	
7							3.5	7	3.5	7	4.5		
Option	SEG7		SEG8		SEG9		SEG10		SEG11		SEG12		
Explanation	PAGE		(When setting SEG3) Standard for mode change Cooling → Heating		(When setting SEG3) Required time for mode change		Long pipe or compensation option for height difference between indoor units		MTFC		-		
Remote Controller Display	-										-		
Indication and Details	Indication	Details	Indication	Details	Indication	Details	Indication	Details	Indication	Details	-	-	
	1		0	1	0	5 min.	0	Use default value	0	Disuse	2	Use	-
			1	1.5	1	7 min.	1	1) Height difference ^(*) is more than 30 m or 2) Distance ^(**) is longer than 110 m					
			2	2	2	9 min.							
			3	2.5	3	11 min.							
			4	3	4	13 min.	2	1) Height difference ^(*) is 15~30 m or 2) Distance ^(**) is 50~110 m					
			5	3.5	5	15 min.							
			6	4	6	20 min.							
7			4.5	7	30 min.								

Setting an indoor unit address and installation option

Option	SEG13	SEG14	SEG15	SEG16	SEG17	SEG18 ^{(*)3}							
Explanation	-	-	-	-	-	Control variables when using hot water / external heater							
Remote Controller Display	-	-	-	-	-								
Indication and Details	-	-	-	-	-	-	-	-	-	Indication	Details		
	2		-	-	-	-	-	-	-			Set temp. for heater On/Off	Delay time for heater On
											0	At the same time as thermo on	No delay
											1	At the same time as thermo on	10 minutes
											2	At the same time as thermo on	20 minutes
											3	1.5 °C	No delay
											4	1.5 °C	10 minutes
											5	1.5 °C	20 minutes
											6	3.0 °C	No delay
											7	3.0 °C	10 minutes
											8	3.0 °C	20 minutes
											9	4.5 °C	No delay
											A	4.5 °C	10 minutes
											B	4.5 °C	20 minutes
											C	6.0 °C	No delay
										D	6.0 °C	10 minutes	
										E	6.0 °C	20 minutes	

^{(*)1} Height difference : The difference of the height between the corresponding indoor unit and the indoor unit installed at the lowest place.
For example, When the indoor unit is installed 40 m higher than the indoor unit installed at the lowest place, select the option "1".

^{(*)2} Distance : The difference between the pipe length of the indoor unit installed at the farthest place from an outdoor unit and the pipe length of the corresponding indoor unit from an outdoor unit.
For example, when the farthest pipe length is 100 m and the corresponding indoor unit is 40 m away from an outdoor unit, select the option "2". (100 - 40 = 60 m)

^{(*)3} Heater operation when the SEG9 of O2 series installation option is set to using hot water heater or when SEG15 is set to using external heater

e.g. 1) Setting O2 series SEG9 = "1" / Setting O5 series SEG18 = "0": Hot water heater is turned on at the same time as the heating thermostat is on, and turned off when the heating thermostat is off.

e.g. 2) Setting O2 series SEG15 = "2" / Setting O5 series SEG18 = "A":

Room temp. ≤ set temp. + f(heating compensation temp.)



- External heater is turned on when the temperature is maintained as 4.5 °C for 10 minutes.

Room temp. > set temp. + f(heating compensation temp.)

- External heater is turned off when the temperature is maintained as 4.5 °C + 1 °C (1 °C is the Hysteresis for On/Off selection.)

Changing a specific option

You can change each digit of set option.

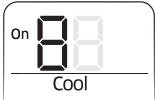
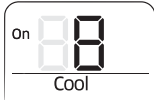
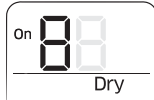
Option	SEG1		SEG2		SEG3	
Explanation	Page		Mode		Option mode to change	
Remote controller display	-					
Indication and Details	Indication	Details	Indication	Details	Indication	Details
	0		D		Option mode	1~6
Option	SEG4		SEG5		SEG6	
Explanation	Tens digit of option SEG to change		Unit digit of option SEG to change		Changed value	
Remote controller display						
Indication and Details	Indication	Details	Indication	Details	Indication	Details
	Tens digit of SEG	0~9	Unit digit of SEG	0~9	Changed value	0~F



- When changing a digit of an indoor unit address setting option, set the SEG3 as 'A'.
- When changing a digit of indoor unit installation option, set the SEG3 as '2'.

NOTE

Ex) When setting the 'buzzer control' into disuse status.

Option	SEG1	SEG2	SEG3
Explanation	Page	Mode	Option to change
Setting	0	D	2
Option	SEG4	SEG5	SEG6
Explanation	Tens digit of option SEG to change	Unit digit of option SEG to change	Changed value
Setting	1	7	1



CAUTION

- If you are using heat pump model, mixed operation mode (two or more indoor units operating in different operation mode simultaneously) is not available when the indoor units are connected to one outdoor unit. If you set the master indoor unit with a remote controller, outdoor unit will operate in the mode which was set in the master indoor unit.

Troubleshooting

If a problem occurs to the air conditioner, the following error codes will appear on the display of the indoor unit or outdoor unit.

Error detection and re-operation

- ▶ If an error occurs during operation, an error code will appear and all the operations are stopped except the display panel.
- ▶ If you re-operate the air conditioner by a remote controller or switch, it will operate normally at first, then detect an error.

Detected errors indicated on display

Error description	Error code
Error on indoor room temperature sensor (Open/short)	E121
1. Error on Eva-in sensor (Open/short)	E122
2. Error on Eva-out sensor (Open/short)	E123
3. Error on discharge temperature sensor (Open/short)	E126
1. Error on outdoor temperature sensor	E221
2. Error on cond sensor	E237
3. Error on discharge sensor	E251
Other outdoor unit sensor errors that are not on the above list	
1. When there is no communication between the indoor and outdoor units for 2 minutes	E101
2. Communication error received from the outdoor unit	E102
3. 3 minute tracking error on outdoor unit	E202
4. Communication error after tracking due to unmatching number of installed units	E201
5. Error due to using the same communication address twice.	E108
6. Error due to incomplete communication address setting	E109
Other outdoor unit communication errors that are not on the above list	
Self diagnosis error display	
1. Error due to opened EEV (2nd detection)	E151
2. Error due to closed EEV (2nd detection)	E152
3. Eva in sensor is detached	E128
4. Eva out sensor is detached	E129
5. Thermal Fuse Open Error	E198

Troubleshooting

Error description	Error code
1. COND mid sensor is detached	E241
2. Refrigerant leakage (2nd detection)	E554
3. Abnormally high temperature on Cond (2nd detection)	E450
4. Low pressure s/w (2nd detection)	E451
5. Abnormally high temperature on discharged air on outdoor unit (2nd detection)	E416
6. Indoor unit shut-down due to unconfirmed error on outdoor unit	E559
7. Error due to reverse phase detection	E425
8. Comp stop due to freeze detection (6th detection)	E403
9. High pressure sensor is detached	E301
10. Low pressure sensor is detached	E306
11. Outdoor unit compression ratio error	E428
12. Outdoor sump down_1 protection control	E413
13. Compressor down due to low pressure sensor protection control_1	E410
14. Simultaneous opening of cooling/heating MCU SOL valve (1st detection)	E180
15. Simultaneous opening of cooling/heating MCU SOL valve (2nd detection)	E181
Other outdoor unit self-diagnosis errors that are not on the above list	
EEPROM error	E162
EEPROM option error	E163
Error due to incompatibility with an indoor unit that special consumption tax is applied.	E164

- * If you turn off the air conditioner when the error display is on, all the displays are turned off.
- * If you re-operate the air conditioner, it will operate normally at first, then detect and display an error again.
- * When E108 error occurs, change the address and reset the system.
e.g. When the address of the indoor unit #1 and #2 are set as 5, address of the indoor unit #1 will become 5 and indoor unit #2 will display E108, A002.

Checking after installation

- ▶ Before supplying power to the product, measure the grounding resistance of power terminal (3 phases: R,S,T,N/1 phase: L,N) and outdoor unit by using a DV 500 V insulation resistance tester.
 - Measured value should be 30 MΩ or above.



- Do not measure the communication terminal as the communication circuit of it can be damaged.
- Check whether the communication terminal becomes short circuit by using a circuit tester.

Trial operation and transference to a user

1. Before supplying power to the product, measure the grounding resistance of power terminal (3 phases: R,S,T,N/1 phase: L,N) and outdoor unit by using a DV 500 V insulation resistance tester.
 - Measured value should be 30 MΩ or above.



- Do not measure the communication terminal as the communication circuit of it can be damaged.
- Check whether the communication terminal becomes short circuit by using a circuit tester.

2. Check the power voltage (L, N) before supplying power and then turn on the switch.

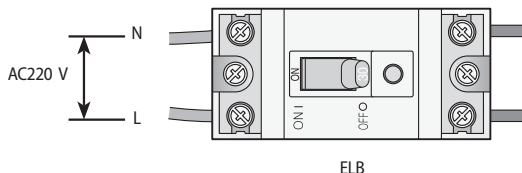

3. After completing the installation, check the followings to make sure indoor unit operates without a problem.

- ▶ Strength of the ground on which indoor unit is installed
- ▶ Refrigerant gas leak
- ▶ Power supply status
- ▶ Insulating capacity of refrigerant pipe insulator
- ▶ Drainage status
- ▶ Connection with a circuit breaker, grounding status
- ▶ Status of each operation mode

4. After completing the trial operation, instruct customers how to use the air conditioner.

- ▶ Turn on/off the air conditioner
- ▶ Operation mode and instruction of each function
- ▶ Cleaning the air conditioner and replacing a filter



- When carrying out the trial operation, operate the indoor unit individually to obtain the S-NET data.
- After completing the installation, trial operation, and transference, advise the users to keep the user's manual and installation manual.

SAMSUNG

