

Installation and user manual **EN**



Filomuro

DC Inverter

SLW

We would first of all like to thank you for having chosen one of our products.

We are sure you will be happy with it because it represents the state of the art in the technology of home air conditioning.

By following the suggestions contained in this manual, the product that you have purchased will operate without problems giving you optimum room temperatures with minimum energy costs.

Innova S.r.l

Compliance

This unit complies with the following European Directives:

- Low voltage 2014/35/UE;
- Electromagnetic compatibility 2014/30/UE ;

Symbols

The pictograms in the next chapter provide the necessary information for correct, safe use of the machine in a rapid,

unmistakable way.

Editorial pictograms

- | | |
|---|--|
| U User | S Service |
| - Refers to pages containing instructions or information for the user. | - Refers to pages containing instructions or information for the installer TECHNICAL CUSTOMER SERVICE. |
| I Installer | |
| - Refers to pages containing instructions or information for the installer. | |

Safety pictograms

- | | |
|---|---|
|  Generic danger |  Danger due to heat |
| - Signals to the personnel that the operation described could cause physical injury if not performed according to the safety rules. | - Signals to the personnel that the operation described could cause burns if not performed according to the safety rules. |
|  Danger of high voltage |  Prohibition |
| - Signals to the personnel that the operation described could cause electrocution if not performed according to the safety rules. | - Refers to prohibited actions. |

Table of contents

Symbols	2
GENERAL	5
General warnings	5
Essential safety rules	5
Product range	6
Rated technical specifications	6
<i>Filomuro</i> overall dimensions	7
Dimensions and weight during transportation	7
Dimensions and weight during transportation	7
INSTALLATION	8
Unit placement	8
Installation procedure	8
Installation clearances	8
Opening of aesthetic parts for installation of equipment and connections	9
High wall mount or flush with floor	11
Installation template (measured)	14
Hydraulic connections	16
Condensate drain	18
Filling the plant	19
Air exhaust when filling the system	19
Wiring	20
CONTROL PANEL INSTALLATION AND CONNECTION	21
ER0689 board connections	21
ER0690 connections	22
Fitting the wall-mounted remote control panel ECA649	23
Spring clamps -AB+ and CP connection	24
CP presence contact input connection	24
ECA649 connections	25
Diagram for BB0698 connections with 3-speed thermostats	26
BB0698 connection with 3-speed thermostats	27
LED signals	27
Water probe management with 3-speed thermostat	28
Diagram for BB0699 connections with 0-10 V DC thermostats/signals	29
BB0699 connections with 0-10 V thermostats	29
LED signals	29
BB0698 board + thermostat BM1151 Wiring diagram	30
BB0698 board + timer BM0152 Wiring diagram	31
OPERATING INSTRUCTIONS WITH REMOTE CONTROL (for command 0689)	32
Warnings	32
Management of the unit with the touch-screen and remote control	32
Functional description	33
Troubleshooting	36
INSTRUCTIONS FOR USE WITH WALL-MOUNTED CONTROL PANEL	37
SMART TOUCH wall-mounted electronic control panel with room probe	37
Display	37
Keys function	37
General start-up	38
Activation	38
Heating / cooling operating mode set-up	38
Stand By	38

Temperature selection	38
Automatic operation	39
Silent operation	39
Night function	39
Operation at maximum ventilation speed	39
Key locking	39
Minimum brightness reduction	39
Deactivation	40
Room temperature probe offset adjustment	40
Long term shut-down	40
Error signals	40
Electronic board with continuous modulation for remote thermostat connection	41
LED Signals (ref. A)	41
ROUTINE MAINTENANCE	42
Maintenance	42
External cleaning	42
Cleaning the air suction filter	43
Suggestions for power saving	44
TROUBLESHOOTING	45
Troubleshooting table	45

1.1 General warnings

- ⚠ After unpacking, make sure that all the components are present. If not, contact your vendor who sold the device to you.
- ⚠ Only qualified installer companies are authorised to install our devices. After having completed installation, the installer will issue a declaration of conformity to the plant manager, as required by the applicable standards and the guidelines provided by constructor's instruction manual supplied with the device.
- ⚠ These devices have been designed for room heating and/or air conditioning and must be used as intended and compatibly with their performance levels.
Any contractual and extra-contractual liability of constructor for harm caused to persons, animals or property by installation errors, improper adjustments, maintenance or use is excluded.
- ⚠ If water leaks out of the device, set the main switch to "Off" and close the water taps.
Contact our Technical Customer Service as soon as possible or professionally qualified staff and do not personally attempt to fix the problem.
- ⚠ If the device is to remain out of service for a prolonged period, make sure you carry out the following operations:
 - Set the main system switch to "Off"
 - Close the water taps
 - If there is danger of frost, make sure that you have added anti-freeze liquid into the circuits, or drain out the system otherwise.
- ⚠ A temperature that is too low or too high is harmful to health and is an unnecessary waste of energy.
Avoid direct contact with the air flow over an extended period.
- ⚠ Avoid keeping the installation premises closed for a long time. Frequently open the windows to ensure proper air circulation.
- ⚠ This instruction manual forms an integral part of the device and therefore must be carefully preserved and must ALWAYS travel with it, even if you transfer the device to another owner or relocate it to other premises.
If the manual gets damaged or lost, request a copy to your local Technical Customer Service.
- ⚠ All repair or maintenance interventions must be performed by the technical service department or by professionally qualified personnel as foreseen in this booklet. Do not modify or intervene on the appliance as this could create dangerous situations and the manufacturer will not be responsible for any damage caused.
- ⚠ Avoid contact: danger of burns.

1.2 Essential safety rules

- ⊖ Please keep in mind that the use of products powered by electricity and water call for operators to comply with certain essential safety rules:
 - ⊖ It is forbidden to children and unassisted disabled persons to use the device.
 - ⊖ It is forbidden to touch the device barefoot or with wet or damp body parts.
 - ⊖ It is forbidden to clean the device before having disconnected it from the mains by setting the main switch of the system to "off".
 - ⊖ It is forbidden to modify the safety or adjustment devices or adjust without authorisation and indications of the manufacturer.
- ⊖ It is forbidden to pull, unplug or twist the device's electric cables, even if it is disconnected from the mains.
- ⊖ Do not introduce objects and substances through the air inlet and outlet grilles.
- ⊖ It is forbidden to open the access doors of the device's internal parts without first having set the main switch of the system to "off".
- ⊖ It is forbidden to dispose of, or leave in the reach of children, the packaging materials which could become a source of danger.

- ⊖ It is forbidden to climb with your feet on the device and/or to place any kind of object on top of it.
- ⊖ The external components of the device can reach temperatures of more than 70 °C.

1.3 Product range

The cooler-radiators of the **Filomuro** range are available in the SLW version for high wall mount installation or flush with the floor in special circumstances. The terminal is available in three different performance levels and sizes, all with two-pipe configuration.

1.4 Rated technical specifications

TECHNICAL DATA (DC)				
<i>filomuro</i>		SLW 400	SLW 600	SLW 800
Coil water content	L	0.54	0.74	0.93
Maximum operating pressure	bar	10	10	10
Maximum water inlet temperature	°C	80	80	80
Minimum water inlet temperature	°C	4	4	4
Hydraulic connections	"	Eurokonus 3/4	Eurokonus 3/4	Eurokonus 3/4
Power supply voltage	V/ph/Hz	230/1/50	230/1/50	230/1/50
Maximum power consumption at maximum speed	W	17.6	19.8	26.5
Maximum power consumption at minimum speed	W	4.8	5.1	5.8
Length	mm	902	1,102	1,302
Height	mm	318	318	318
Depth	mm	128	128	128
Weight	kg	14	16	19

1.5 Filomuro overall dimensions

2 pipes

	U.M.	SLW 400	SLW 600	SLW 800
Dimensions				
L	mm	902	1,102	1,302

SLW

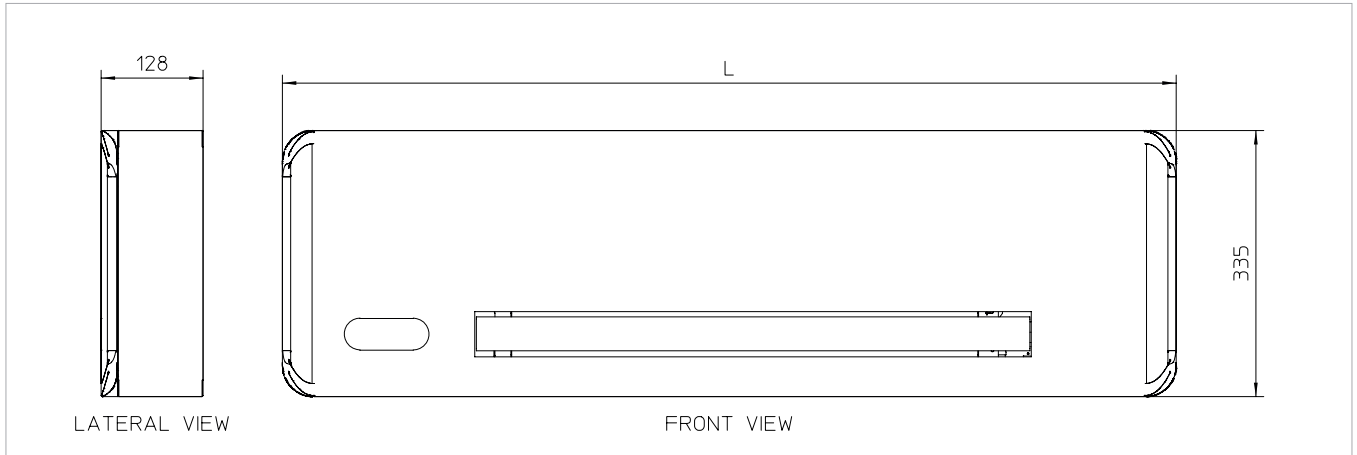

1.6 Dimensions and weight during transportation

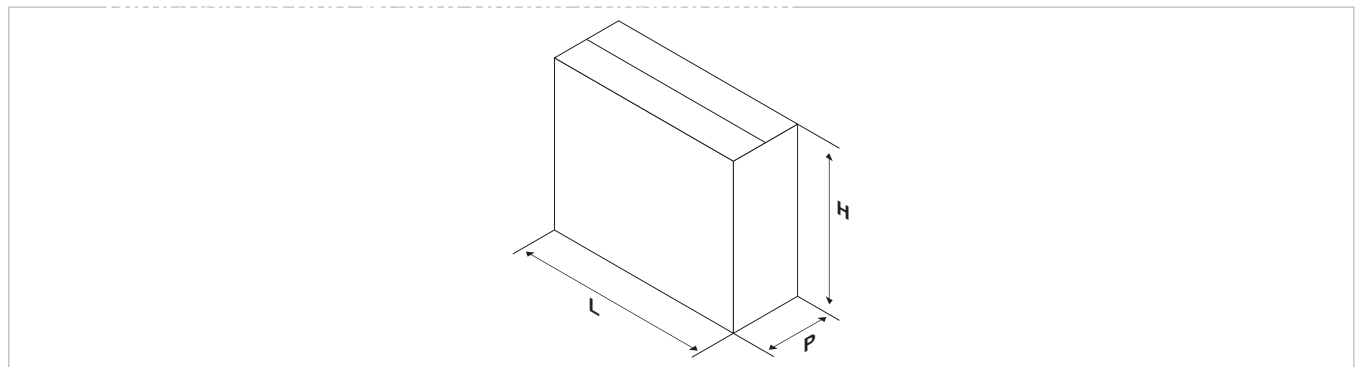

	M.E.	SLW 400	SLW 600	SLW 800
	kg	15	17	20
L	mm	1,035	1,235	1,435
H	mm	490	490	490
D	mm	213	213	213

INSTALLATION

2.1 Unit placement

- ⚠** Avoid installing the unit near:
- areas exposed to direct sunlight;
 - heat sources;
 - in damp areas and areas in which the unit can come into contact with water;
 - in environments with oil mists;
 - in environments subject to high frequencies.
- ⚠** Make sure that:
- the wall on which you intend to install the unit has an appropriate structure and capacity;
 - the wall surface is not crossed by pipelines or power lines;
 - the wall is perfectly level;
 - there are no obstructions nearby that could compromise the inlet and outlet airflow;
 - the wall on which you are installing the unit is (if possible) an external perimeter wall, in order to allow condensate drain outside the premises;
 - air flow is not directed towards by-standers.

2.2 Installation procedure

The assembly steps described below and their drawings refer to a version of the machine with connections on the right side.

For ideal installation and performance levels, carefully follow the instructions in the manual. Failure to do so may cause system malfunctions and automatically voids the warranty, and relieves the constructor of any harm caused

2.3 Installation clearances

The figure shows the minimum distances required of the fan coil from the walls and furniture on site.

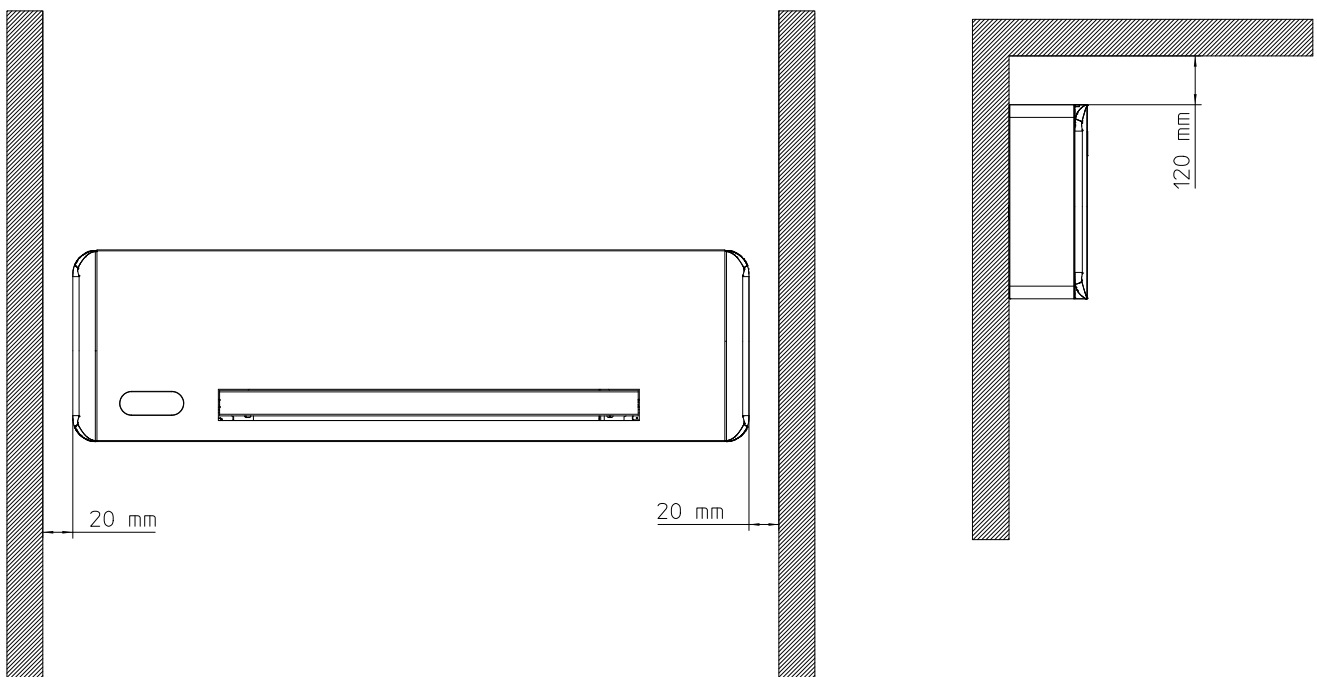

2.4 Opening of aesthetic parts for installation of equipment and connections

- Remove the side panels by unthreading them upwards - Remove the aesthetic front panel as shown in the figure; as shown in the figure below;
- Remove the 6 hex screws present on the sides of the front panel;

A	side panels
B	aesthetic front panel

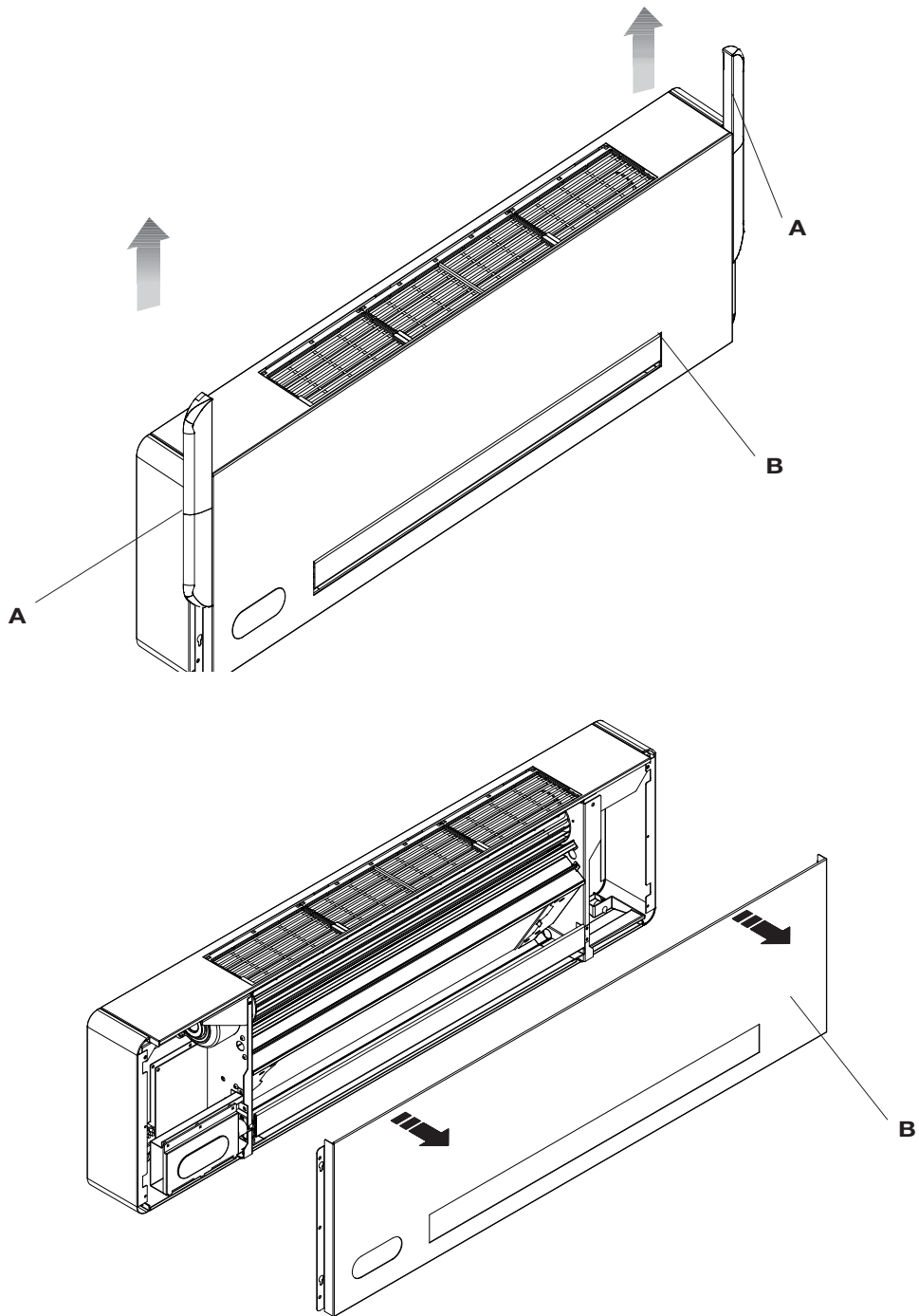

- Remove the upper grille by unthreading it in your direction - remove the side panels by lifting them upwards;
- and lifting it upwards, as shown in the figure;

A	upper grille
B	side panels

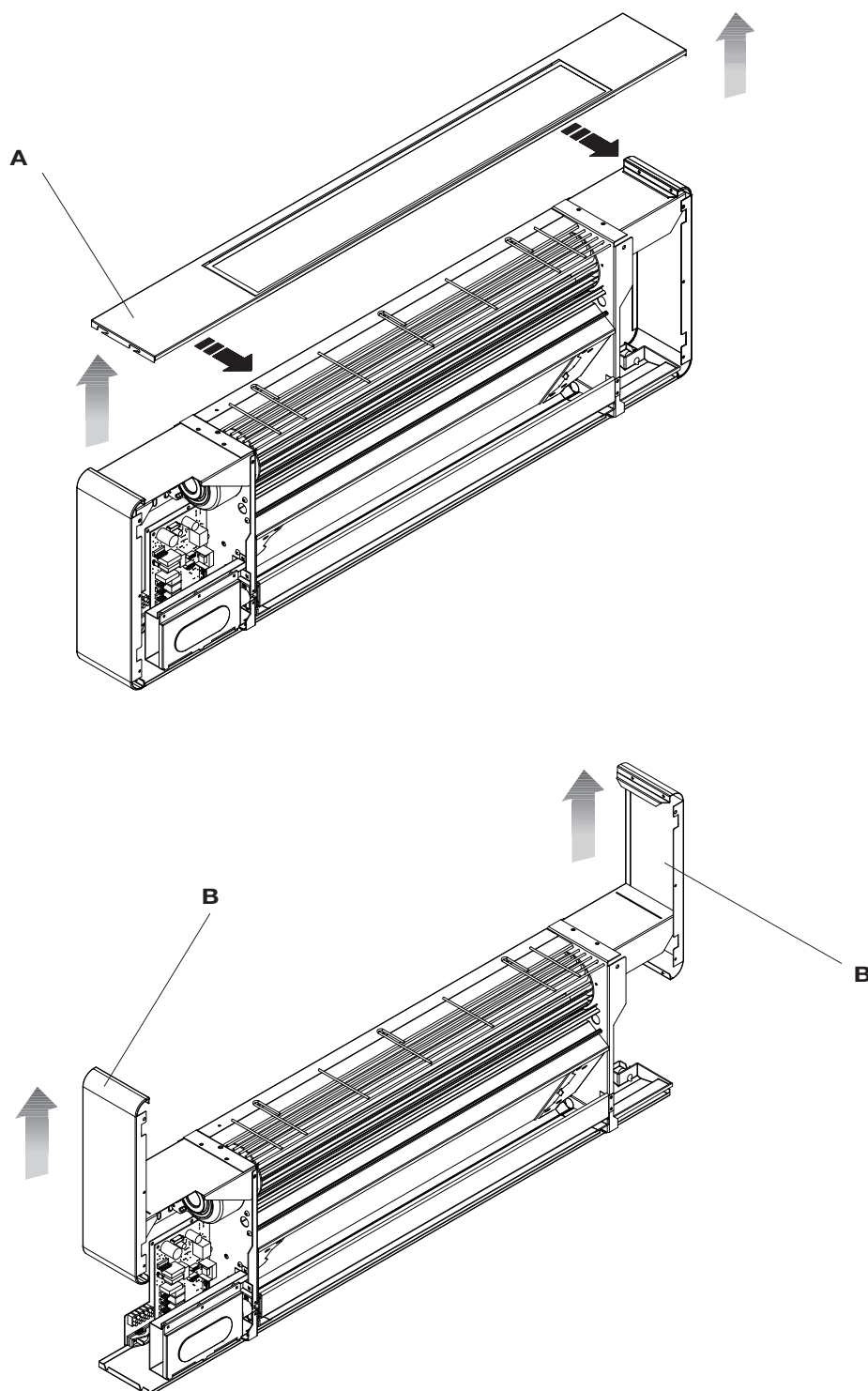

2.5 High wall mount or flush with floor

- For smooth installation, especially if you want to set-up the system before you install the device, we recommend installing a built-in cistern, as shown in the figure;
- If you do not complete installation of the device when installing the cistern, leave the water and condensate drain pipes hanging loose, so that you can later make the connections without joints;
- When you finally install the device, it will be possible to connect the cooler-radiator with a 90° fitting and socket with eurokonus connection;
- another option if you can comfortably bend the pipeline (which will depend on the depth of the installed cistern) is to install the eurokonus connection inside the pipeline;
- pay attention to the tilt angle of the condensate drain pipe, which must rest be laid on the lowermost part of the cistern so that the pipe's height never exceeds the height of the cooler-radiator drain connection;
- for the installation heights, refer to the installation template supplied with the device and which is shown in the following pages.

A	built-in cistern
B	connecting water pipelines

C	condensation drainage pipe
D	<i>filomuro</i> cooler-radiator

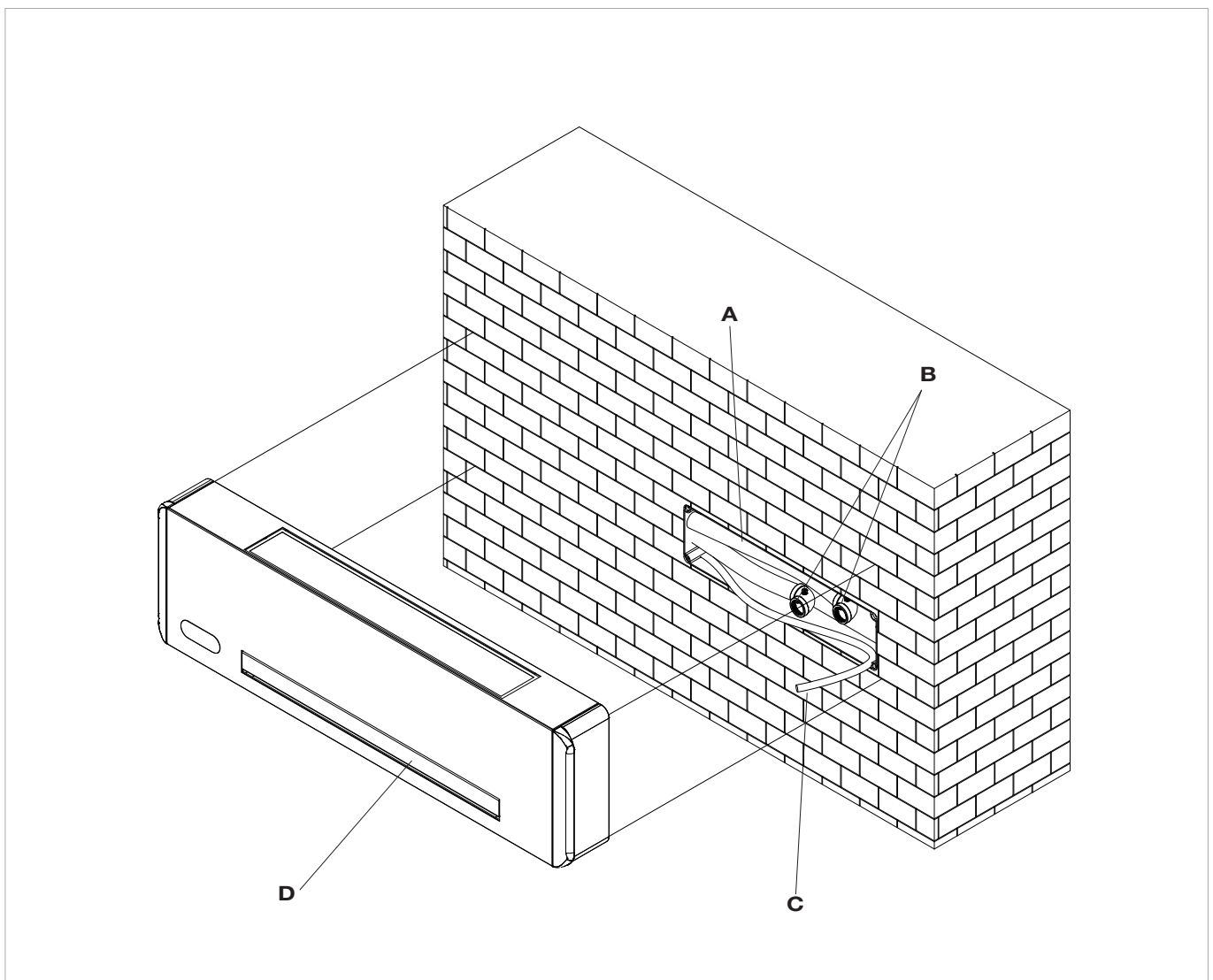

1. Use the paper template shown in full scale on the next page and trace the position of the two fixing brackets on the wall.
2. Drill a hole using a proper tip and insert the plugs (2 per bracket) then attach the two brackets. Do not over-tighten the screws so that you can adjust them with a spirit level.
3. Firmly fasten the brackets by tightening the four screws.
4. Check stability by moving the brackets to the right and left, up and down.
5. Assemble the unit, making sure it fastens properly onto the brackets and that it is stable.
6. Make sure the tilt angle of the cooler-radiator matches the measure shown in the figure below.

A plugs

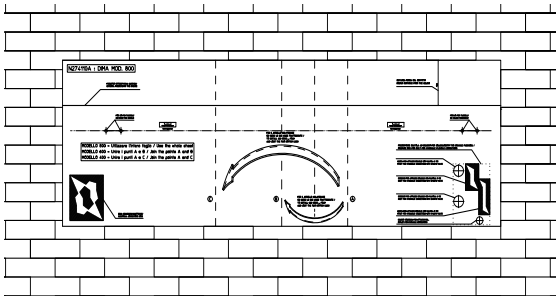

1.

B brackets

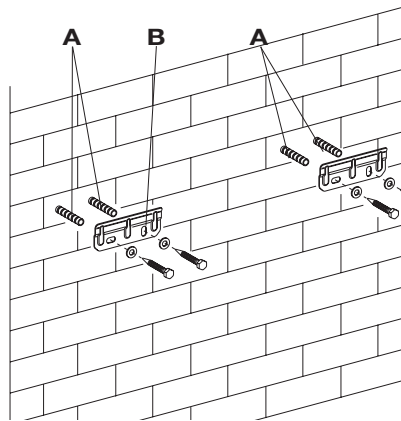

2.

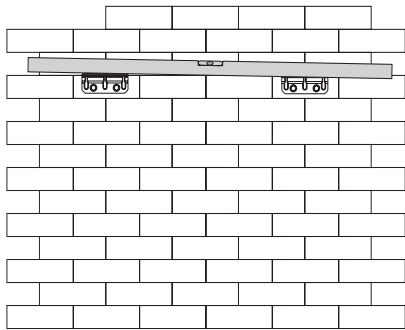

3.

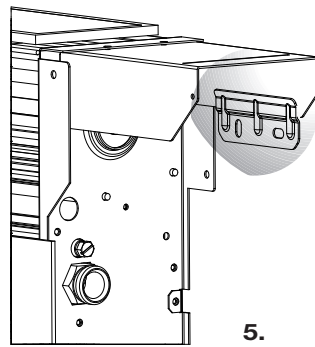

5.

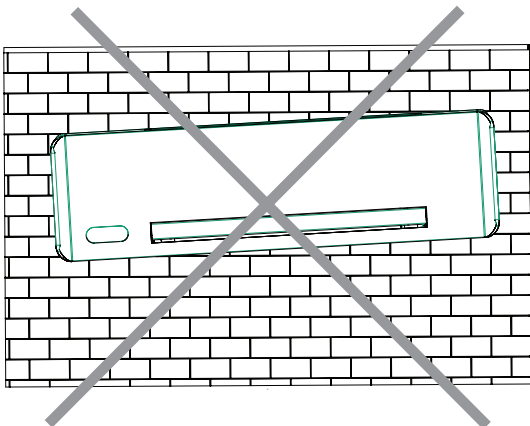

6. NO

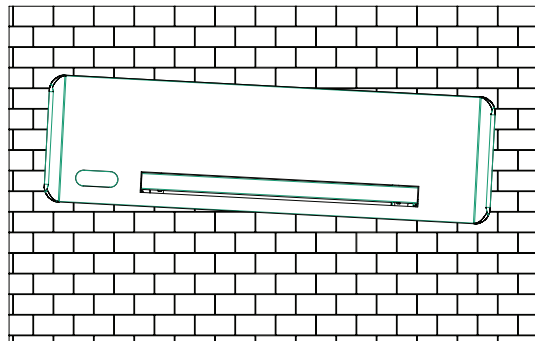

6. OK, max. tilt 1°

2.6 Installation template (measured)

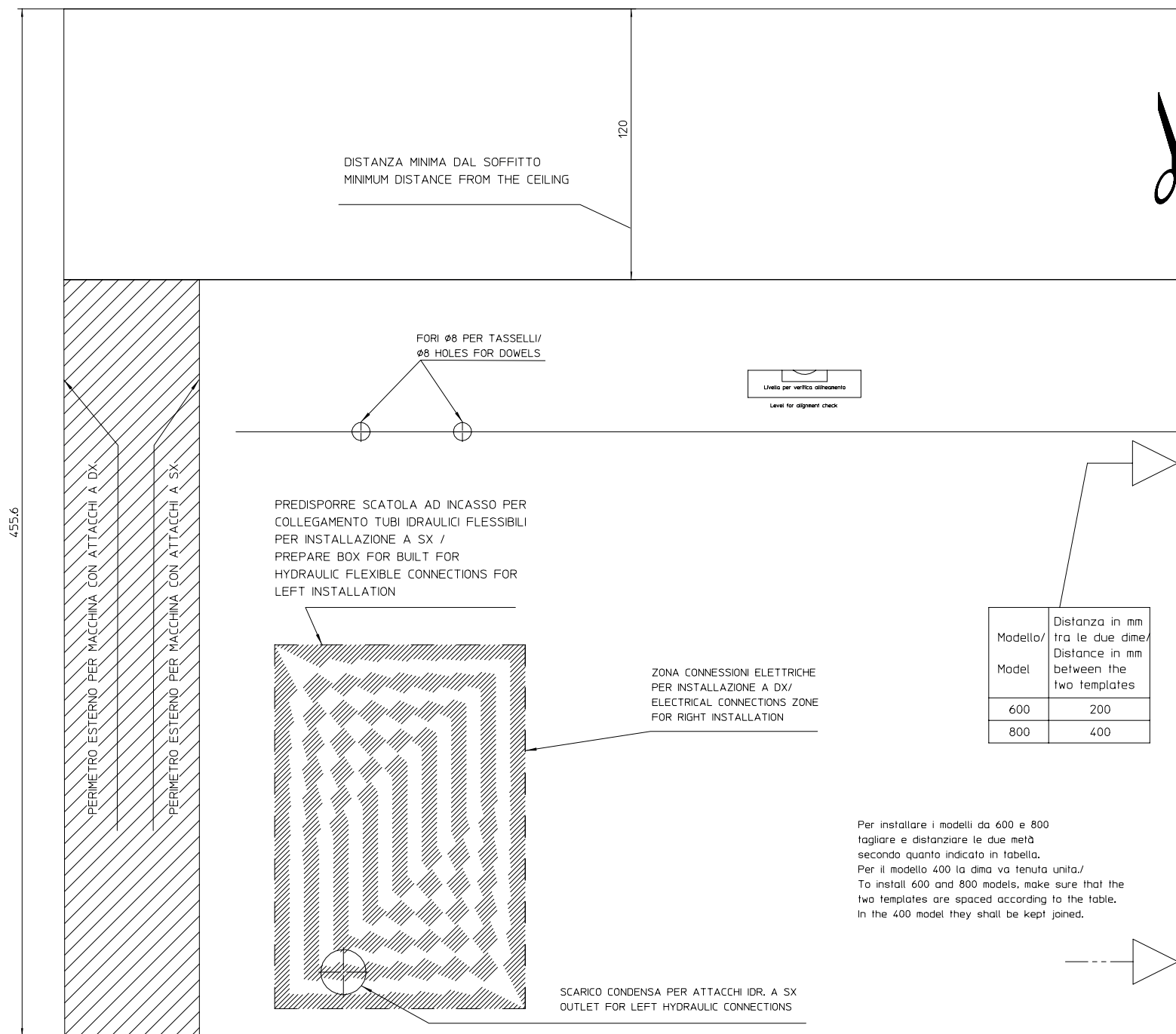

DIMA cod. N274110A
 TEMPLATE cod. N274110A

PERIMETRO SUPERIORE DELLA MACCHINA/
 UPPER PERIMETER OF THE MACHINE

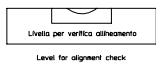

FORI Ø8 PER TASSELLI/
 Ø8 HOLES FOR DOWELS

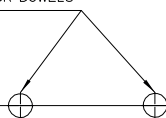

PREDISPORRE SCATOLA AD INCASSO PER
 COLLEGAMENTO TUBI IDRAULICI FLESSIBILI
 PER INSTALLAZIONE A DX /
 PREPARE BOX FOR BUILT FOR
 HYDRAULIC FLEXIBLE CONNECTIONS FOR
 RIGHT INSTALLATION

Modello/ Model	Distanza in mm tra le due dime/ Distance in mm between the two templates
600	200
800	400

ZONA CONNESSIONI ELETTRICHE
 PER INSTALLAZIONE A SX/
 ELECTRICAL CONNECTIONS ZONE
 FOR LEFT INSTALLATION

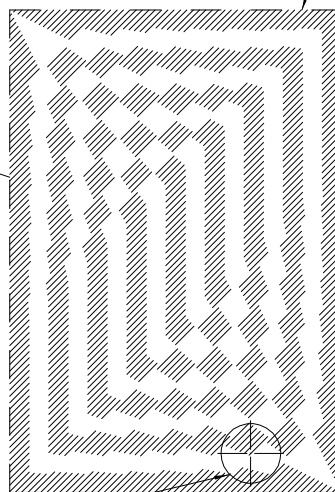

PERIMETRO ESTERNO PER MACCHINA CON ATTACCHI A DX

PERIMETRO ESTERNO PER MACCHINA CON ATTACCHI A SX

Per installare i modelli da 600 e 800 tagliare e distanziare le due metà secondo quanto indicato in tabella. Per il modello 400 la dima va tenuta unita. / To install 600 and 800 models, make sure that the two templates are spaced according to the table. In the 400 model they shall be kept joined.

PERIMETRO INFERIORE DELLA MACCHINA/
 LOWER PERIMETER OF THE MACHINE

SCARICO CONDENZA PER ATTACCHI IDR. A DX
 OUTLET FOR RIGHT HYDRAULIC CONNECTIONS

2.7 Hydraulic connections

	U.M.	400	600	800
Pipeline diameter	mm	14	16	18

The engineer is responsible for choosing the right water lines and their size, in accordance with good installation practices and the applicable laws, keeping in mind that under-sized pipelines lead to poor system operation.

To make the connections:

- position the water lines
- tighten the connections using the "wrench against wrench" method
- check for any fluid loss
- apply a lining to the connections (use proper insulating material)

The hydraulic lines and fittings must be thermally insulated.

Avoid partial insulation of the pipes.

Avoid over-tightening the pipes to avoid damage to the insulation.

To ensure water tightness of the threaded connections, use hemp and green paste; the use of teflon tape is recommended if you have poured anti-freeze liquid in the water circuit.

Carefully check that the insulation is tight, in order to prevent the formation and dripping of condensate.

Connection of the fan coil flush with the wall with a 2-way manual valve (code I20686)

No electrical connections are necessary if you opt for the 2-way manual valve.

Simply connect the pipeline to the delivery and return lines as shown in the figure, with the delivery line at the bottom;

A	fan coil
C	thermoelectric motor

IN	water inlet pipe fitting
OUT	water outlet pipe fitting

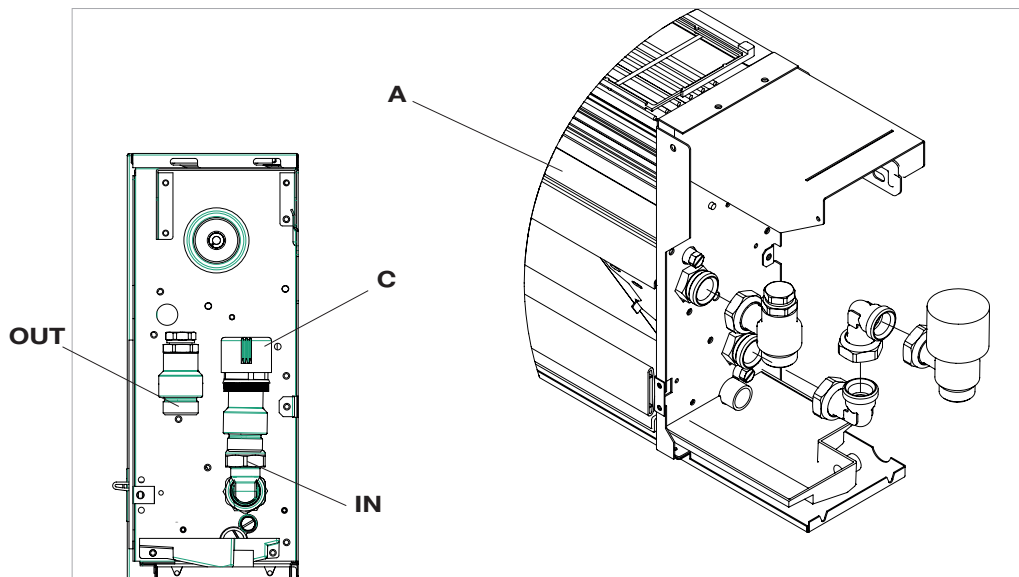

Connection of the fan coil flush with the wall with a 2-way valve and thermoelectric command (V20687)

Connect the pipeline to the delivery and return lines as shown in the figure, with the delivery line at the top;

Comply with the requirements for electrical connections, as described in para. 2.13

A	fan coil
B	electric cable entry hole
C	thermoelectric motor

IN	water inlet pipe fitting
OUT	water outlet pipe fitting

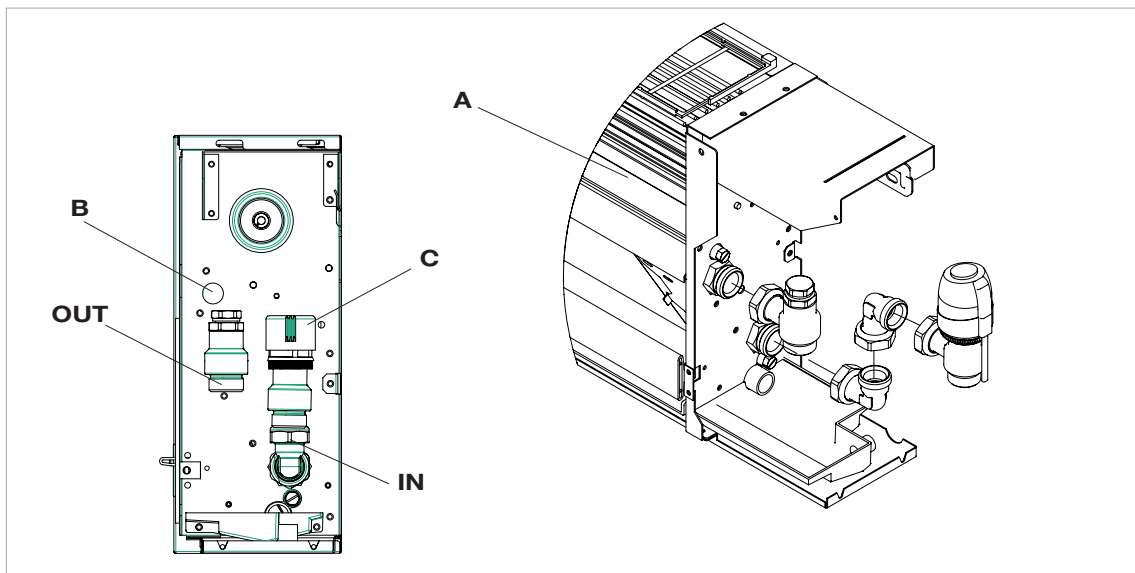

Connect the filomuro cooler-radiator to the 3-way diverter valve unit with thermo-electric motor (V30688)

Connect the pipeline to the delivery and return lines as shown in the figure, with the delivery line at the top;

Comply with the requirements for electrical connections, as described in para. 2.13

A	fan coil
B	electric cable entry hole
C	thermoelectric motor

IN	water inlet pipe fitting
OUT	water outlet pipe fitting

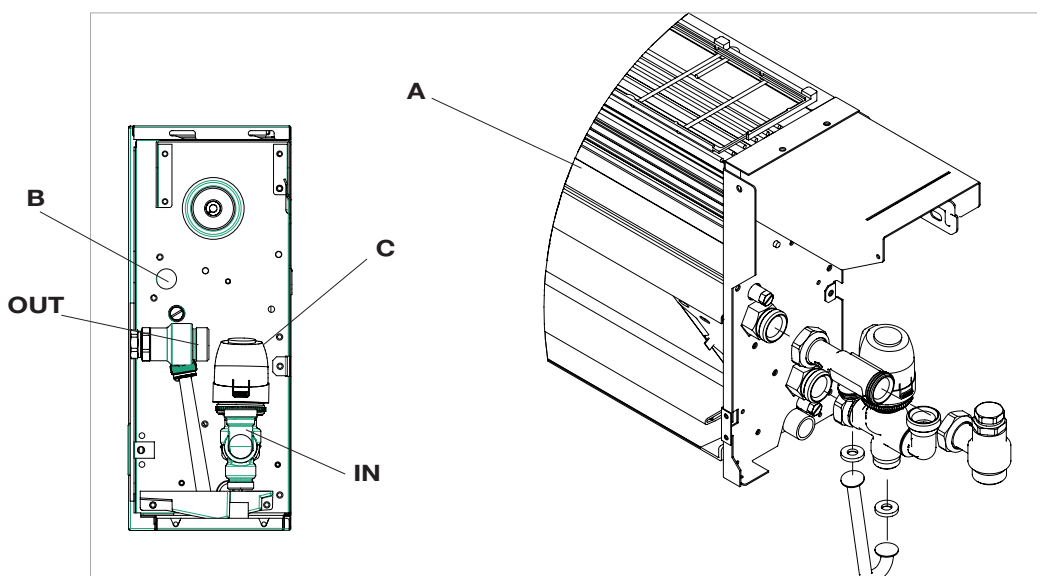

2.8 Condensate drain

The condensate drain network must be sized appropriately (minimum inner pipe diameter: 14 mm) and the pipeline positioned so that it maintains a consistent slope along the line (never less than 1%). The drain pipe connects directly to the drain pan installed at the bottom on the side panel under the hydraulic connections.

- If possible, make the condensate liquid flow directly onto a gutter or into a "white water" drain.
- If the liquid is discharged into a sewer, we recommend that you install a trap-vent to prevent bad odours from rising back up into the building. The curve of the trap must be lower than the condensate tray.
- If you need to drain the condensate into a container, it must remain open and the pipe must not be immersed in water to prevent adhesion and back-pressure that would obstruct free flow.
- If the drain pipe has to overcome a gap in height due to its particular installation which would obstruct condensate

flow, remember to install a pump:

These pumps are commonly available on the market.

However, it is advisable that after installing the pump you check proper flow of the condensate liquid, pouring it in very slowly (about 1/2 l of water in about 5-10 minutes) into the drain pan.

Condensate drain pipe assembly

Connect the drain connection of the drain pan that collects the condensate fluid to a hose and tighten it properly. Make

sure the drip-guard extension is present and that it has been properly installed.

A	drain connection
B	liquid drain pipe

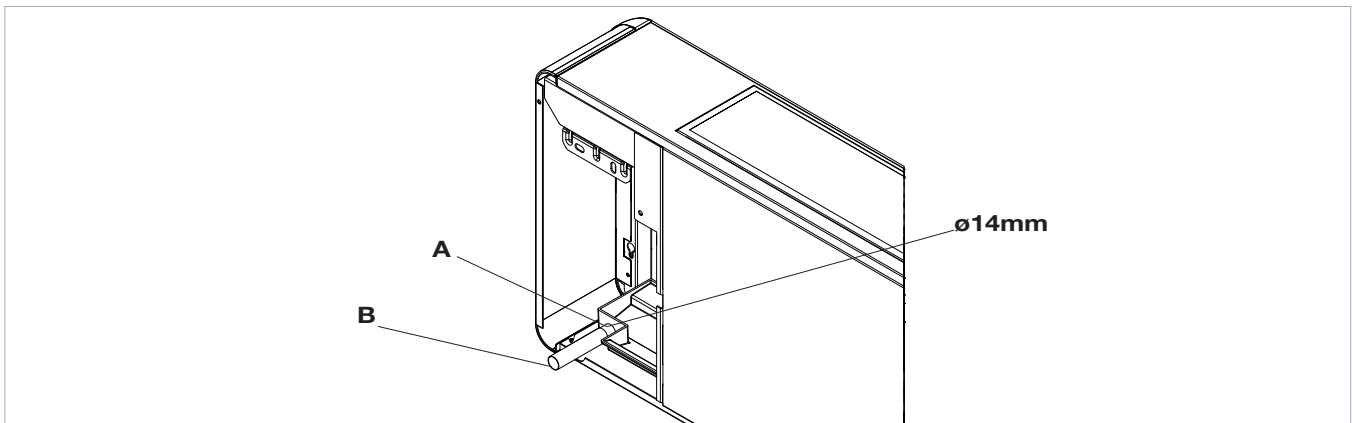
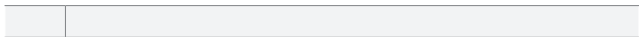

Pay attention to the tilt of the condensate drain pipe when it channels condensate outside the premises as shown in the figure.

A	fan coil
B	condensate drain pipe

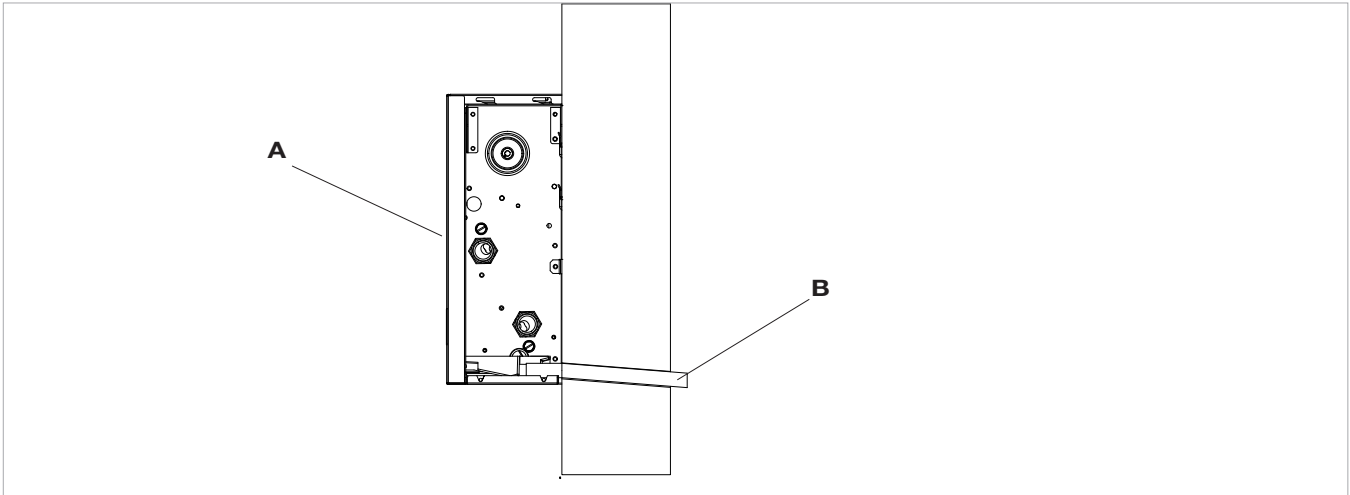

2.9 Filling the plant

When starting the system, make sure that the fan coil is already running, use its cap to press the valve shutter and lock-shield on the hydraulic unit is open. If there is a power black-out and the thermal valve is open it.

2.10 Air exhaust when filling the system

- Open all the system's shut-off devices (whether manual or automatic); Check the tightness of the gaskets.
- Start filling the system by slowly opening the water tap;
- With the aid of a screwdriver, work the vent on the uppermost coil connection (see figure below); We recommend that you repeat this operation whenever the device has been running for a few hours and that you regularly check the system's pressure.
- When water begins to leak out of the breather valves, close them and continue to fill the system (as per the rated specifications).

A	Coil vent
----------	-----------

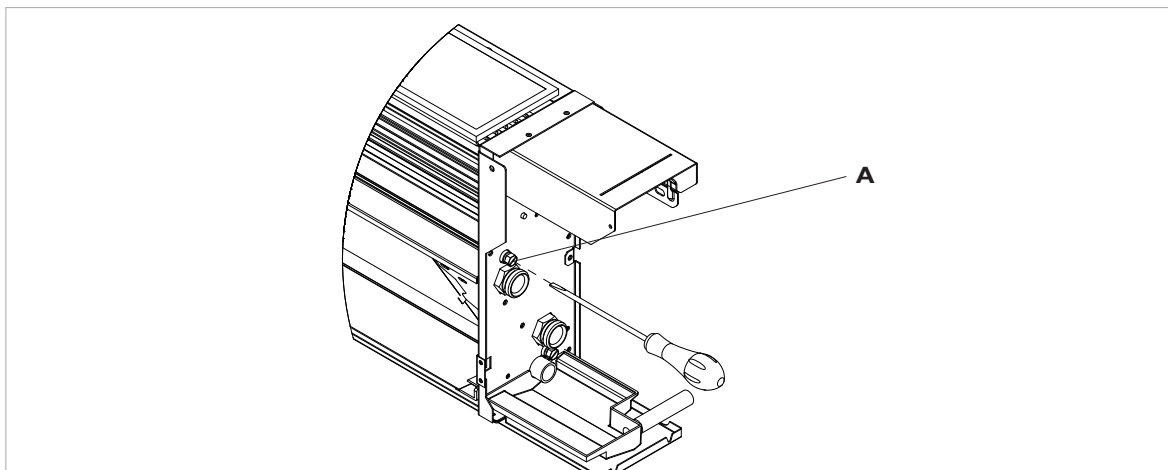

2.11 Wiring

- Access the electrical parts as described in para. 2.4.
- An on/off switch with delayed fuses or an automatic circuit breaker (2A) must be installed to supply power to the system.
- Because the wiring features a suppression filter, as required by the applicable laws and standards, which naturally induces micro-dispersion on the ground, it is best to install selective circuit breakers upstream of the system.
- For safety reasons, the on/off switch referred to above should be installed near the device or at any rate in open view.
- The power cables must be equipped with copper conductors having the following unitary sections (the values indicated refer to a maximum line length of 15 mm). The cables must be appropriate for the type of installation, in accordance with the applicable CEI standards.

	U.M.	SLW 400	SLW 600	SLW 800
Power conductor (phase + neutral)	mm ²	1.5	1.5	1.5
protective conductor section G/V	mm ²	1.5	1.5	1.5

CONTROL PANEL INSTALLATION AND CONNECTION

EN

3.1 ER0689 board connections

- ⚠ Before you connect the cooler-radiator, make sure that:
 - the voltage and frequency match the values on the device's nameplate.
 - The power line has an efficient ground connection and is appropriately sized for the unit's maximum current absorption (minimum cable section: 1.5 mm²).

in the upper part of the wall).
In any case, you must check that the power supply is protected against overload and/or short-circuits.

- ⚠ If you need to replace the power cable, contact only the technical customer service or qualified staff, in compliance with the applicable national laws.

In order to prevent any risk of electric shock, it is essential to disconnect the main circuit breaker before making any electrical connections and performing maintenance on the equipment.

You can use a cable embedded in the wall in the position traced with the installation template to make the electrical connection (recommended connection for devices installed

H2	water temperature probe 10 kΩ
M1	fan motor DC inverter
EV	water solenoid valve (230V/50Hz 1A powered output)
L-N	230V/50Hz electrical power supply connection
G	protective conductor

CP	presence sensor input (if closed, the fan coil goes into stand-by.)
AIR	Optional air probe (*)
DISPLAY	control panel (display) wiring

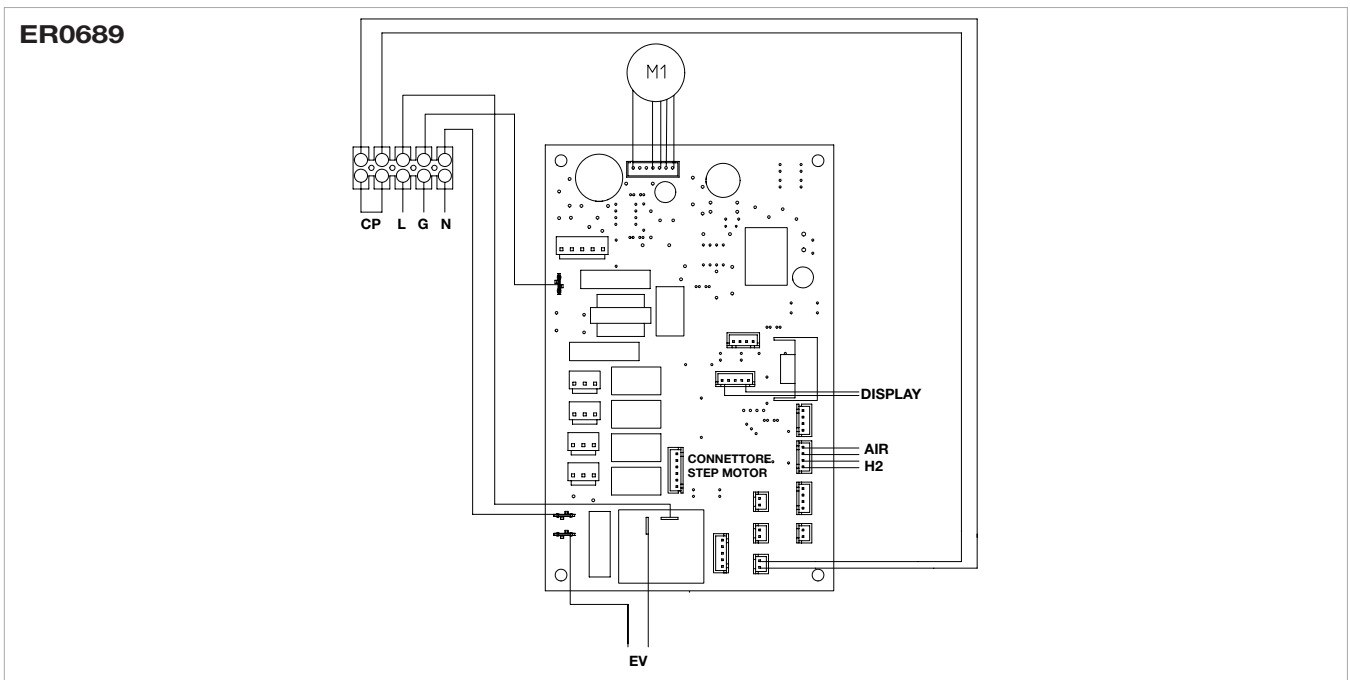

CP presence contact input connection

When the CP contact opens (connected to a clean contact, not live) the unit is in stand-by mode and the display reads "CP".

that inhibits the unit as: opening window contact, remote on/off, infrared presence sensor, enabling badge, etc.

Through this contact, you can connect an external device

3.2 ER0690 connections

-AB+	serial connection for wall-mounted remote control ECA649 (respect the AB polarisation)
H2**	hot water temperature probe 10 kΩ
M1	fan motor DC inverter
Y1	hot water solenoid valve (230V/50Hz 1A powered output)
L-N	230V/50Hz electrical power supply connection
BO	boiler go-ahead output (free contact max 1A)
CH	chiller go-ahead output (free contact max 1A)
CP	presence sensor input (if closed, the fan coil goes into stand-by.)
AIR	Optional air probe (*)
SM	Step motor (diffuser)

*	Connect as an alternative to the air probe of the ECA649 wall-mounted control panel
**	If after powering the equipment the board detects the probe, the start-up will take place under normal conditions with minimum water temperature in heating (30 °C) and maximum water temperature in cooling (20 °C) functions. The board can also operate without a water probe, case in which the fan stop thresholds will be ignored

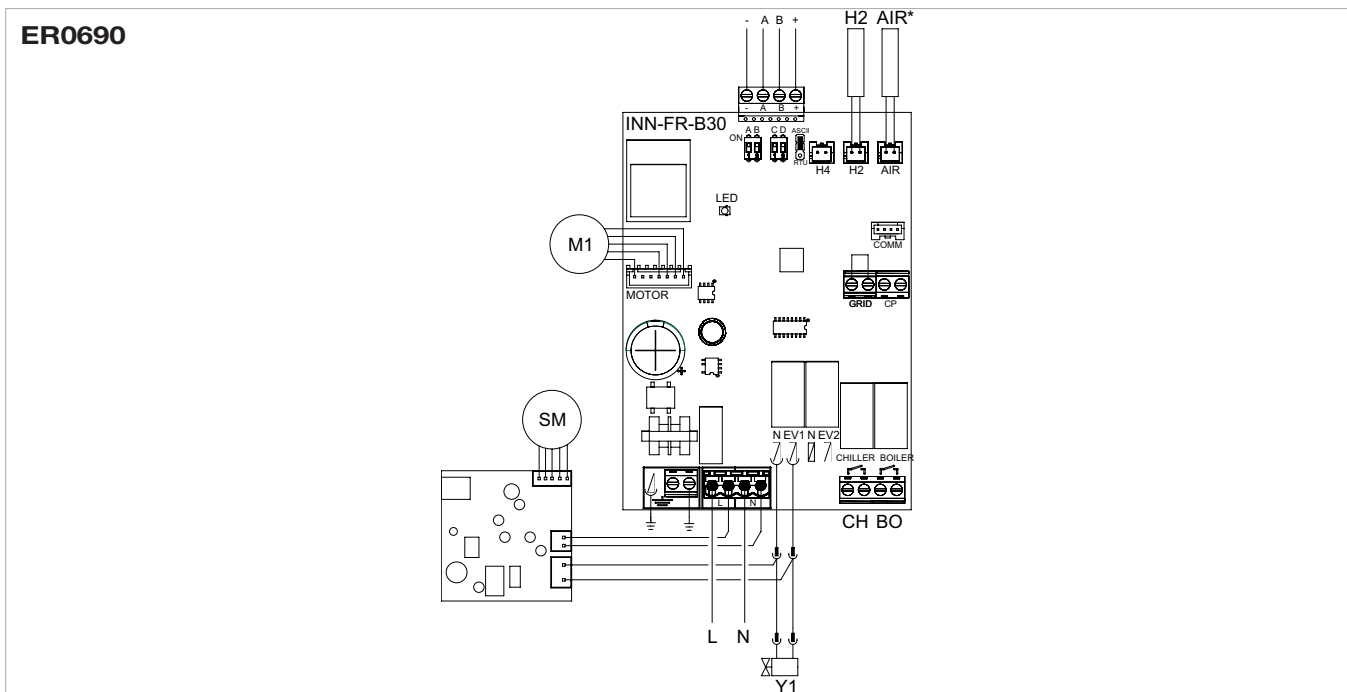

The 4 spring terminals (ref. A) intended for the connection of the ECA649 wall-mounted control panel are compatible with 0.2 to 1.5 mm² section (0.75 mm² if connecting 2 conductors to the same terminal) rigid or flexible cables, while if they are provided with lugs with plastic collar, their maximum section should be of 0.75 mm².

Strip the cable by 8 mm and then if the cable is rigid you should be able to insert it easily while if it is flexible you will need to use some nose pliers. Insert the cables completely and make sure they are properly fixed by pulling them slightly.

3.3 Fitting the wall-mounted remote control panel ECA649

The wall-mounted ECA649 is an electronic thermostat (fitted with temperature probe optionally removable in one of the fancoils connected to it) with the possibility of controlling one or more cooler-convactor/cooler-radiators (up to a maximum of 30) equipped with electronic control for allowing remote control ER0690.

Install the wall-mounted remote control ECA649 away from doors or windows and sources of heat (heaters, convectors, stoves, direct sunlight), on internal walls at a height of about 1.5 m from the floor.

The wall-mounted remote control is already assembled in the package, therefore before mounting them the two parts must be disconnected by unhooking the two protruding notches

on their back (A).

Use the base of the control (ref. B in figure) to trace the fixing point on the wall (use the two opposite holes).

Then proceed with the operations below:

drill the holes in the wall;

route the electric wires through the window on the base;

fix the base of the control to the wall using suitable plugs;

perform the electrical connection and then close the control paying attention not to crush the conductors.

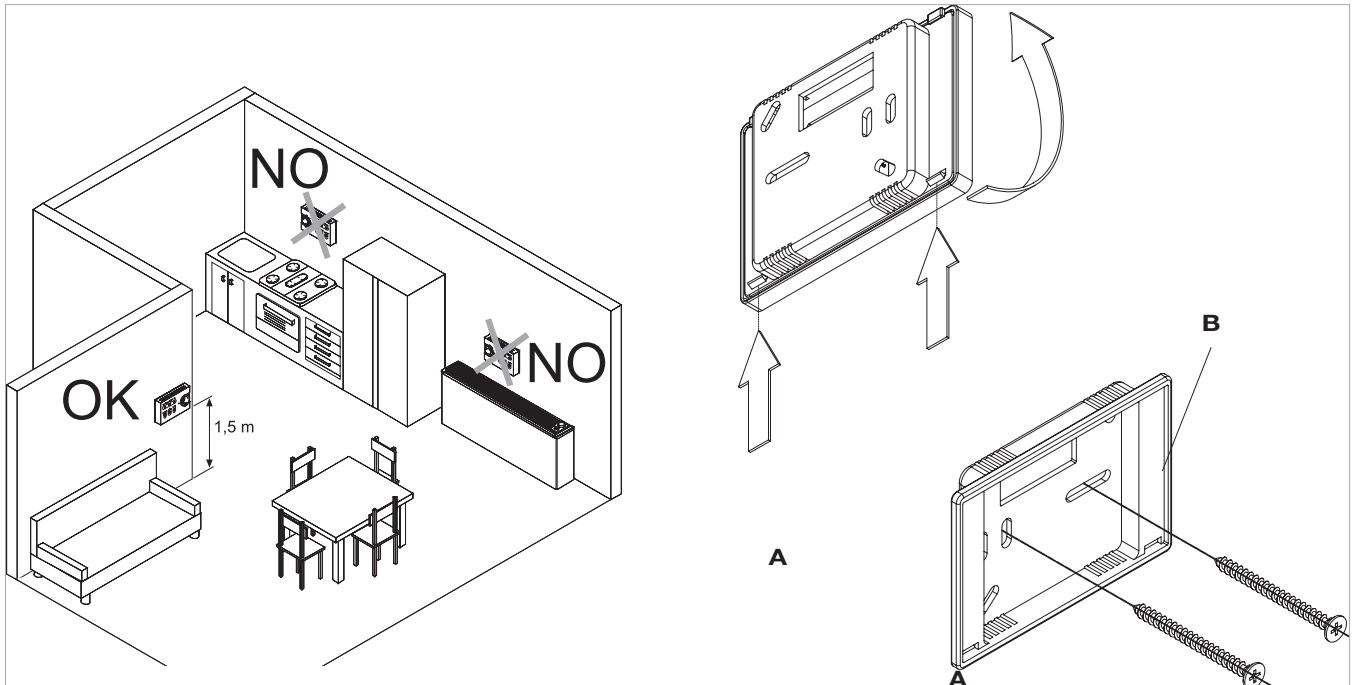

3.3.1 Spring clamps -AB+ and CP connection

The spring terminals intended for the electrical connections are compatible with 0.2 to 1.5 mm² section rigid or flexible cables, while if they are provided with lugs with plastic collar, their maximum section is reduced to 0.75 mm².

For correct and secure connection follow the operations below:

strip the cable by 8 mm as shown below;

if the cable is rigid you should be able to insert its end easily, while if it is flexible you should use a pair of nose grippers;

insert the cables completely and make sure they are properly fixed by pulling them slightly;

To disconnect the cables use a screwdriver to press the corresponding white notch (ref.C) and remove the conductor.

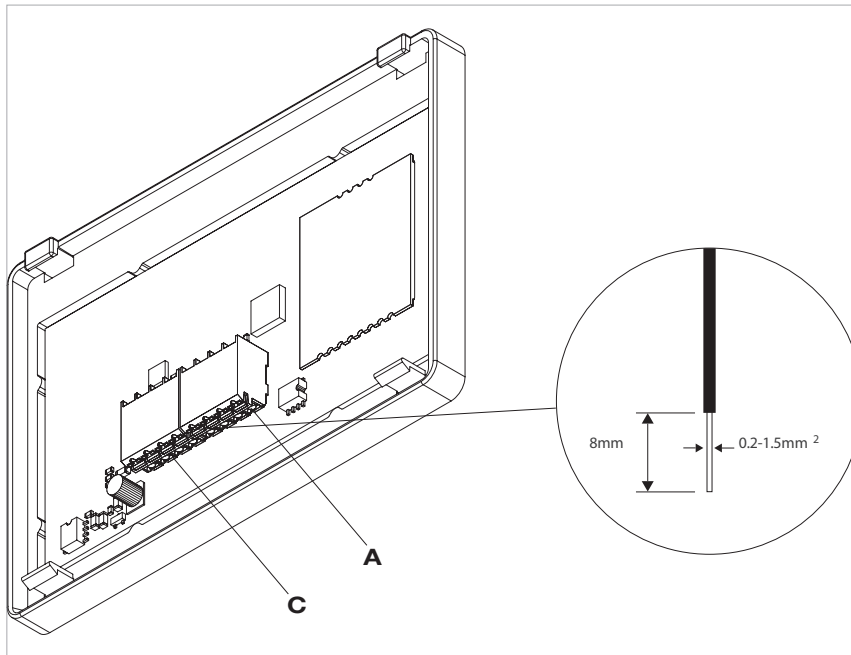

3.3.2 CP presence contact input connection

When the contact connected to the CP (ref. A) input is closed all the users connected will be switched off. If the contact is open the unit is active, if the contact is closed the unit is deactivated and by pressing a key the symbol  flashes.

 The input cannot be connected in parallel to one of another electronic board (use separate contacts).

3.3.3 ECA649 connections

Connect the RS485 line of the wall-mounted remote control to one or more (up to a maximum of 30) units equipped with electronic remote control ER0690 through a bipolar cable suitable for RS485 serial connection, keeping it separate from power supply cables.

the indications "A" and "B" on each peripheral device connected (for the connection it is preferable to use a bipolar shielded cable with a minimum section of 0.35 mm²);

- Chase out the wall in order to minimise the length of the leads;
- complete the line with the 120 Ω resistance supplied;
- do not make "star" connections;
- the connection with cable RS485 is polarised, observe

connect the + and - power supply terminals of the wall-mounted terminal, 5 V DC voltage, on one of the ER0690 boards, respecting the polarities.

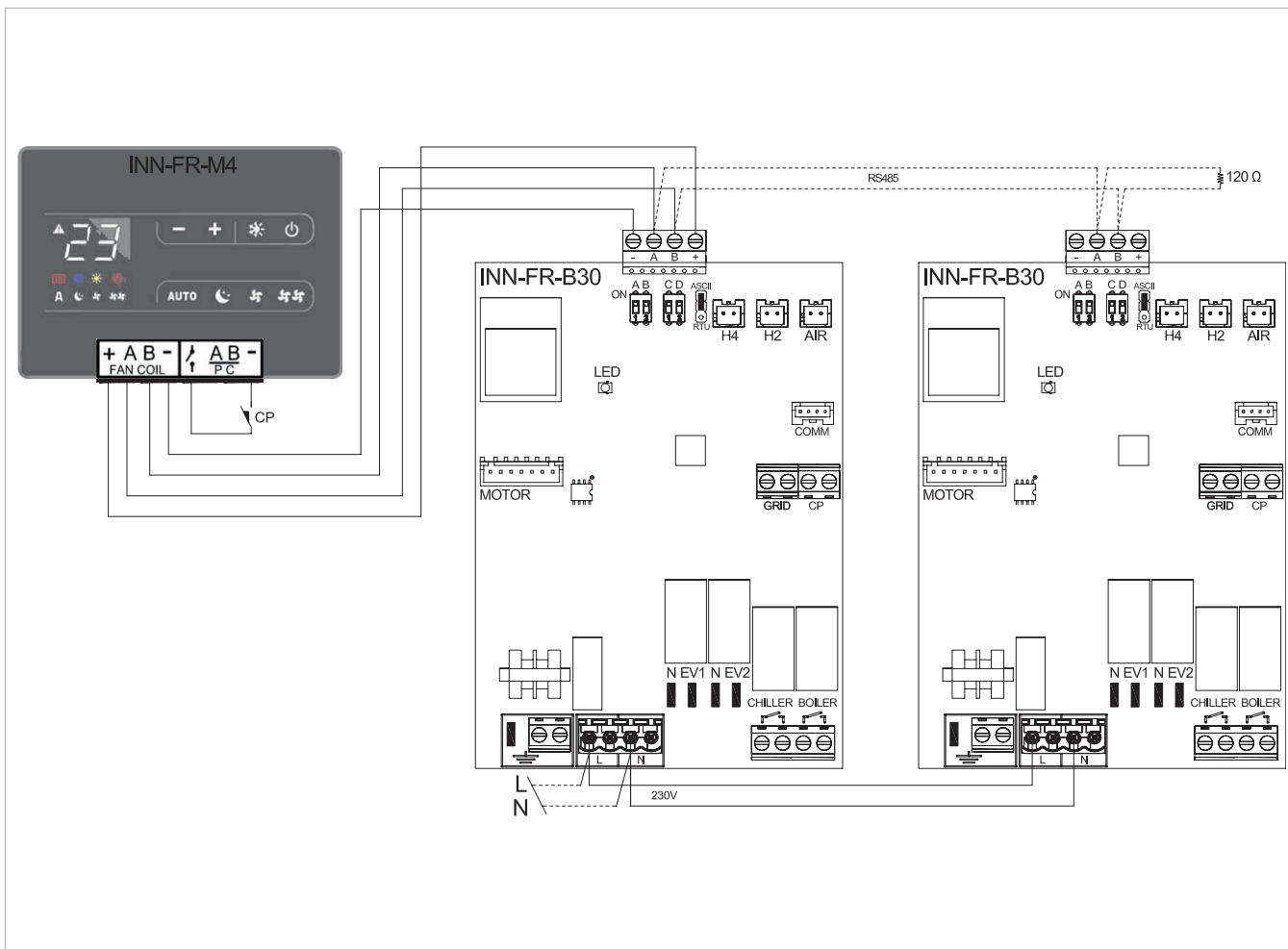

3.4 Diagram for BB0698 connections with 3-speed thermostats

Make the electrical connections to a thermostat that is suitable for the purpose, according to the diagram in the picture

L-N	230V-50Hz electric power supply
EV	electrovalve consent input
V1	maximum fan speed
V2	medium fan speed
V3	minimum fan speed
V4	supersilent speed
E	heating, cooling selection input. See Water probe management paragraph
Y1	hot water solenoid valve (230 V/50 Hz 1A powered output)
M1	fan motor DC inverter
SM	Step motor (diffuser)

TA	3 speed thermostat (to buy, install and connect by the installer)
CV	thermostat consent
SV	speed selector
H2*	water temperature probe (10 kΩ)
*	located in the battery on the machine. See the Water probe management paragraph

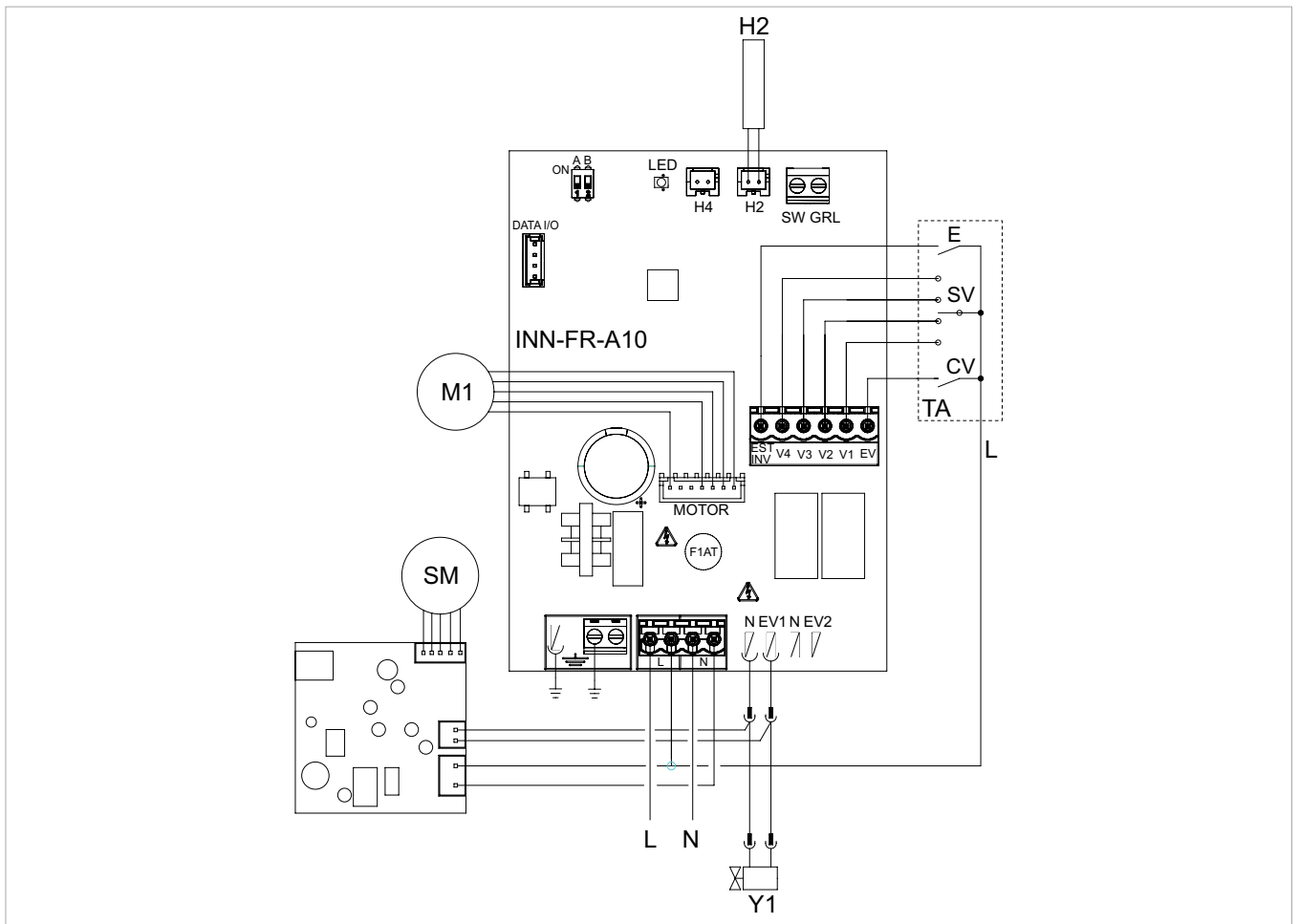

3.4.1 BB0698 connection with 3-speed thermostats

The CV input is the ON/OFF of the board, which goes into stand-by with the input open. It must be bridged to clamp L of the 230V electric power supply to activate the electrovalve Y1.

The 4 inputs of speeds V1, V2, V3 and V4, when bridged to clamp L of the 230 V electric power supply, activate the fan. The sequence is: maximum speed (equal to 1400 rpm on clamp V1), medium speed (1100rpm on clamp V2), minimum speed (680rpm on clamp V3) and supersilent speed (400rpm on clamp V4).

Connect the 3 speeds of the thermostat to 3 of the 4 available inputs based on the characteristics and use of the location:

for example connect the medium V2, minimum V3 and supersilent V4 speeds for residential application that requires maximum silence, or connect V1, V2 and V3 for commercial application where the heating capacity is the main aspect.

In the event of simultaneous closure of several inputs, the motor will run at a number of revolutions equal to that set by the connection with the highest speed.

One can connect several boards in parallel to a single thermostat, even using several speeds.

3.4.2 LED signals

The LED (ref. A) is off if input CV is not closed (stand-by condition).

It is switched on upon closure of contact CV and signals standard operation.

- It emits a single flash + pause for fan stop alarm due to unsuitable water (with H2 water probe connected).
- 2 flashes + pause for motor alarm (for example jamming due to foreign bodies or fault in the rotation sensor).
- 3 flashes + pause for water probe alarm disconnected or faulty.

3.4.3 Water probe management with 3-speed thermostat

If the BB0698 board is used with electromechanical thermostats, or other commercial commands, provided with water probe, the on-board H2 probe will not be connected and the fan will be controlled from remote.

If the command does not feature a water probe management function, this function can be performed by the board instead by connecting the 10 kΩ probe located inside the battery to the H2 connector on the board (ref. B).

In this case the board runs the minimum water temperature functions for the heating mode and the maximum water temperature functions in the cooling mode; therefore if the water temperature is not suitable for active operation (above 20°C during the cooling mode, under 30°C in the heating mode) ventilation is stopped and the anomaly is signalled by a single flash + pause of the LED (ref. A). The heating/cooling discriminant is implemented through the SUM-

WIN input (ref. C) of the board: by leaving the input open, the board goes into heating mode; by closing it, it goes into cooling mode.

If after having connected the probe, it is disconnected or it detects inconsistent values (for example installation of a 2 kΩ probe instead of the correct one of 10 kΩ) the fault is signalled with 3 flashes + pause of the LED (ref. A) and by the operation block.

To confirm operation without the board disconnect and reconnect the board power.

This condition is stored by the board for all subsequent start-ups.

In any case, once the probe is connected normal operations are restored with temperature thresholds.

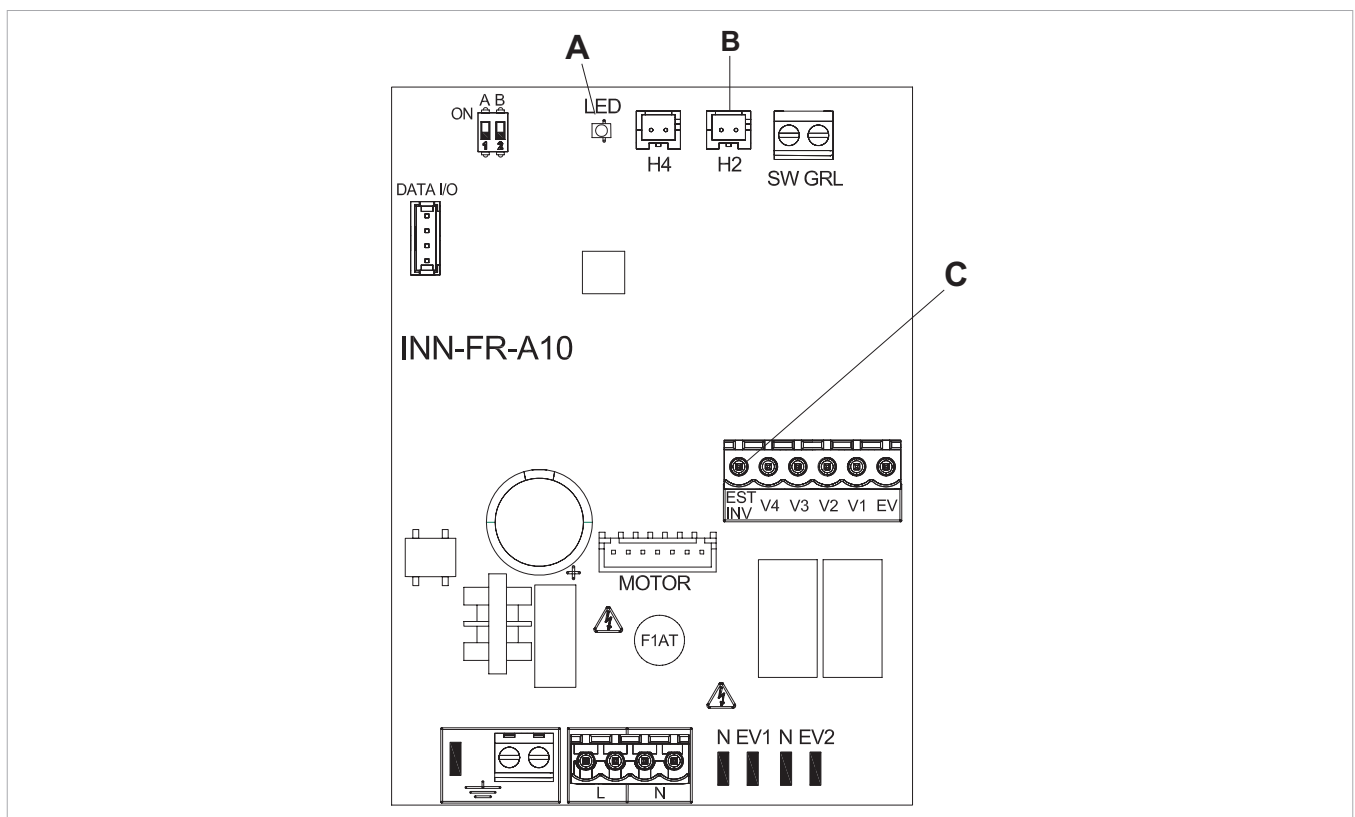

3.5 Diagram for BB0699 connections with 0-10 V DC thermostats/signals

Make the electrical connections to a thermostat that is suitable for the purpose, according to the diagram in the picture

L-N	230V-50 Hz electric power supply
10V	device pilot input 0÷10 V
Y1	hot water solenoid valve (230V/50Hz 1A powered output)

SM	Step motor (diffuser)
M1	fan motor DC inverter

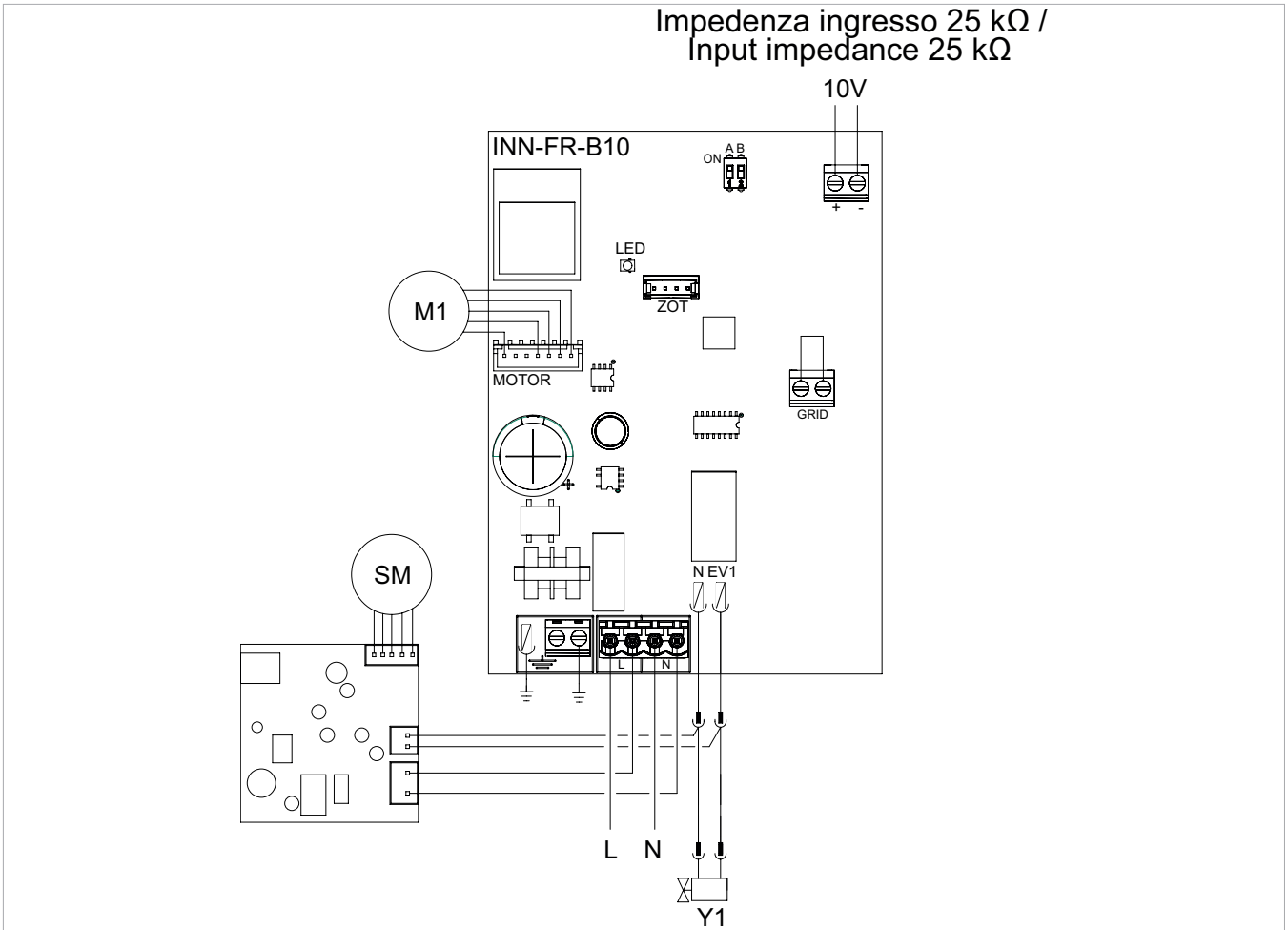

3.5.1 BB0699 connections with 0-10 V thermostats

The 10 V input activates solenoid valve Y1 and adjusts the number of rotations of the fan. The Y1 valve is enabled by voltage > 1 V DC and turns off when the same falls below 0.9 V DC.

The speed "ramp" provides a linear adjustment from the minimum value (400rpm) to the maximum value (1400rpm) for voltage values ≥ 1.1V÷10 V DC.

The motor is off with values below 1 V DC.

3.5.2 LED signals

The LED (ref. L) is off if the input signal is below 0.9 V. It is switched on for values over 1 V and signals standard operation.

- 2 flashes + pause for motor alarm (for example jamming due to foreign bodies or fault in the rotation sensor).

3.6 BB0698 board + thermostat BM1151 Wiring diagram

The wall-mounted control BM1151 is an electronic thermostat for powering an electrovalve and a presence sensor input (if with ON/OFF switch, a three-speed switch and a summer/winter switch. The control must be combined with the remote adjustment control BB0698. It is equipped with a live output

L-N	230V-50 Hz electric power supply
CP	presence sensor input (if closed, the fan coil goes into stand-by.)
EV	Enable input
V1	Max fan speed (1,400 rpm)
V2	Med fan speed (1,100 rpm)
V3	Min fan speed (680 rpm)
V4	Supersilent speed (400 rpm).

Y1	Water solenoid valve (230 V/50 Hz 1A powered output)
SM	Step motor (diffuser)
M1	DC inverter fan motor

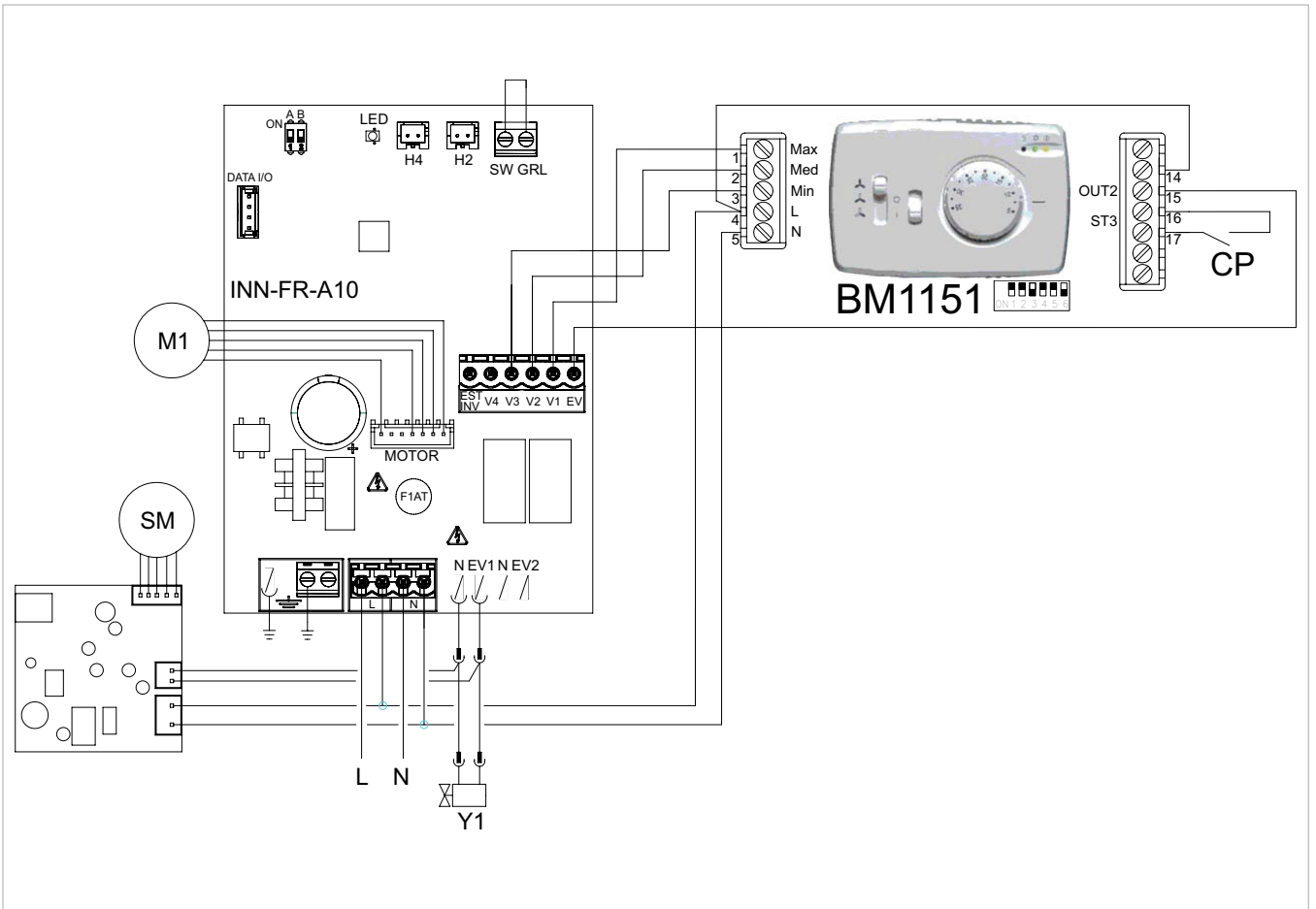

3.7 BB0698 board + timer BM0152 Wiring diagram

The built-in control kit BM0152 allows to adjust all the functions during the heating mode (30 °C) and maximum functions of the fan coil. It is equipped with a live output of 3 °C. It must be fitted in combination with the remote adjustment control BB0698.

adjusts the room temperature by acting on the three speeds of the fan coil. If it is connected to the 10 kΩ* water probe located in the device battery well, it controls the minimum

L-N	230V-50 Hz electrical supply
EV	Enable input
V1	Max fan speed (1,400 rpm)
V2	Med fan speed (1,100 rpm)
V3	Min fan speed (680 rpm)
V4	Supersilent speed (400 rpm)
Y1	water solenoid valve (230 V/50Hz 1A powered output)

SM	Step motor (diffuser)
M1	fan motor DC inverter
H2	Water temperature probe (10 kΩ*) located in the battery on the machine
*	The built-in control BM0152 allows, by setting an appropriate parameter, the management of the 2 kΩ temperature probes installed on the previous versions.

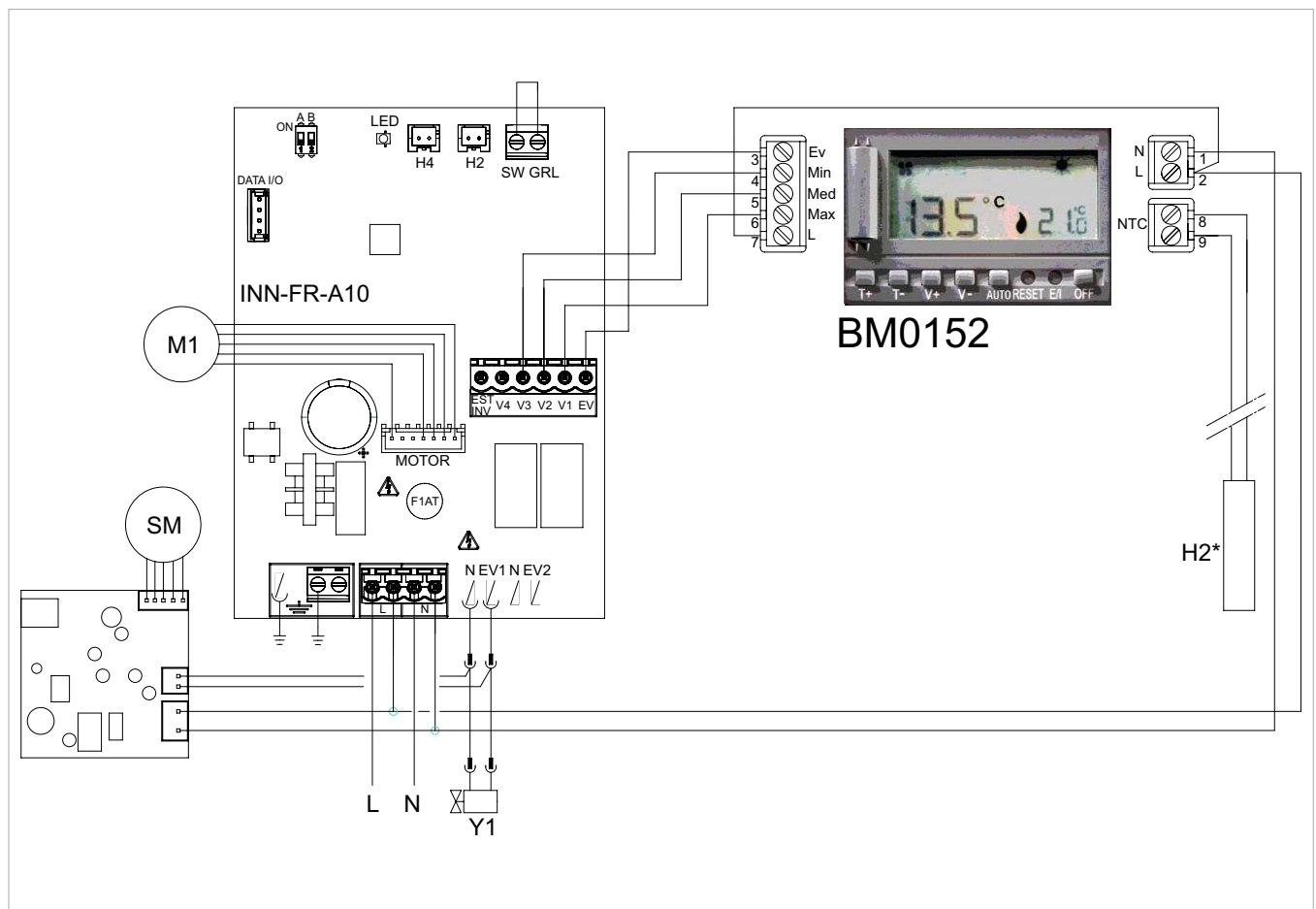

OPERATING INSTRUCTIONS WITH REMOTE CONTROL (for command 0689)

4.1 Warnings

- ⚠ Do not lean or sit on the body of the cooler-radiator to avoid damaging it.
- ⚠ Do not manually move the horizontal louver of the air outlet. Always use the remote control to move the louver.
- ⚠ If water leaks from the device, you must switch it off immediately and disconnect the power supply. Then, call the nearest customer service centre.
- ⚠ The device must not be installed in rooms where there are explosive gases or where there are conditions of humidity and temperature out of the limits defined in the installation manual.
- ⚠ Regularly clean the air filter as described in the relevant paragraph.

4.2 Management of the unit with the touch-screen and remote control

- 1 Remote control
- 2 Touch-screen display

KEY / DISPLAY:

- | | | | |
|--|--|--|--|
| | Setpoint | | Key to enable heating only mode (2) |
| | Up key | | Night comfort key |
| | Down key | | Airflow direction control key |
| | On/off key | | Fan speed control key |
| | Key to enable cooling only mode | | Key to set the Timer function (1) |
| | Key to enable dehumidification only mode | | Key to set the Timer function (2) |
| | Key to enable ventilation only mode | | Light sensor |
| | Key to enable heating only mode (1) | | Digital thermometer;
1÷7 bars - red in winter, blue in summer |
| | | | Not used |

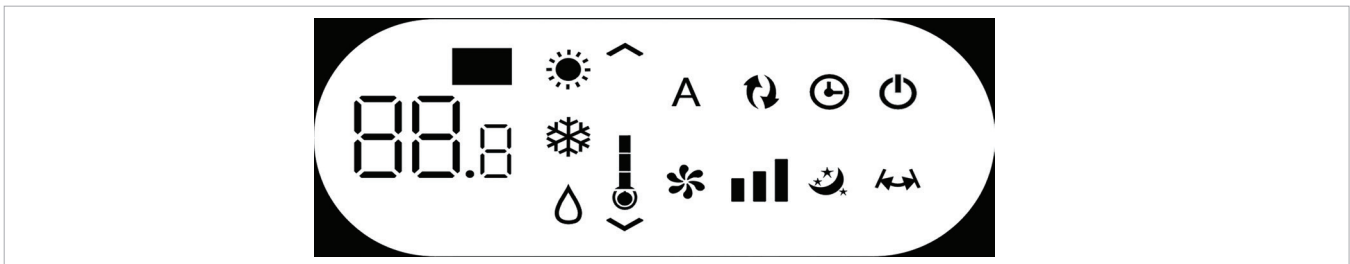

Normally the display shows the operating status (see the symbols. Functional description chapter) and any alarms (see the Alarms display paragraph). You can also select the various functions by pressing on the

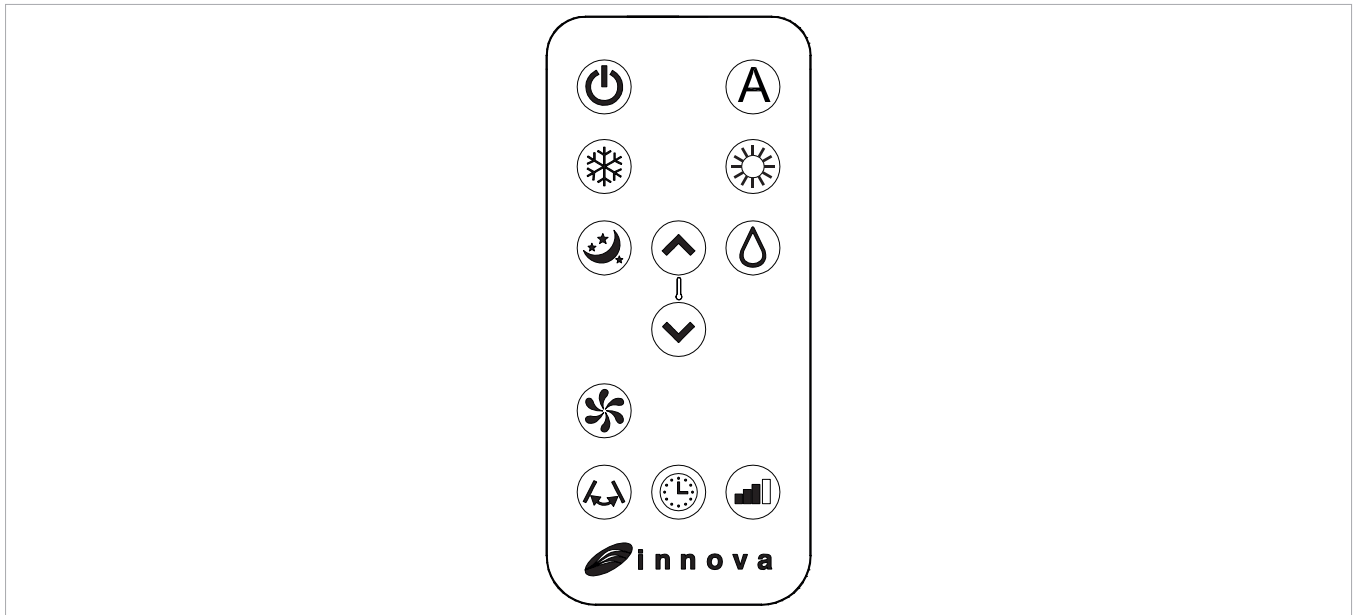

You can set the various functions by pressing the keys (see the keys function chapter).

device while you are using the remote.

⚠ The remote control supplied with the device is designed to provide maximum sturdiness and exceptional functionality, but should nonetheless be handled with caution.

Moreover:

- if other devices are being used within the premises that are operated by remote control (TVs, radios, stereos, etc.), you might experience some interference
- electronic and fluorescent lamps can interfere with communications between the remote control and the device.
- remove the battery in case of prolonged inactivity of the remote control.

Avoid:

- leaving it exposed to rain, spilling liquid on the keyboard or dropping it in water
- bumping it forcefully or letting it fall on hard surfaces
- leaving it exposed to direct sunlight
- placing obstacles between the remote control and the

Inserting the battery

Use only a dry 3V lithium battery CR2025 (included) with the remote control. Used batteries must be disposed of appropriately (WEEE) through special waste collection centres provided by the local authorities.

remote control. Make sure to insert the battery according to the +/- polarity. Close the cover after inserting the battery.

To insert the battery, open the slot on the bottom of the

4.3 Functional description













Main switch-on and operation







To control the device with the remote control or touch-screen display, make sure you have enabled the main switch on the power line (the technician who installed the device can help you locate the switch), or introduce a power plug on the device, plugging it into the system's socket.

unit, point the front of the remote towards the unit's display. The buzzer will emit a beep and a message will appear on the display to confirm that the command has been enabled. The maximum range to send commands is about 8 metres.

After you perform these steps, you can operate the system either by pressing the symbols on the touch-screen display or using the remote control. To send commands to the indoor



Key/Display	Operation
⚠	The keys of the remote control and touch-screen display perform the same function.
	When the unit is switched on, the preset set-point appears on the 3 digits of the display.
	<ul style="list-style-type: none"> • The room temperature set-point can range between 16 and 31 °C.
	⚠ Do not set a temperature that is too low or too high is harmful to health and is an unnecessary waste of energy.

Key/Display	Operation
	<p>Power on/off</p> <p>By pressing the appropriate key, you can switch the device off (standby) or on. The control panel has its own memory, therefore no settings will be lost in case of shut-down or power outage. The key is used to activate or deactivate the unit for short periods.</p> <p> If you plan to keep the device out of service for a prolonged time, remember to deactivate it by disconnecting the power or removing the power plug.</p>
	<p>Cooling only mode</p> <ul style="list-style-type: none"> When this operating mode is enabled, the device dehumidifies and cools the room.
	<ul style="list-style-type: none"> The temperature can be set between 16 and 31 °C. If the set temperature is lower than the room temperature, after three minutes (at the most) the cooler-radiator will start running and the device begins to deliver cold air, continuing to ventilate the room even if the device reaches the set-point.
	<p>Dehumidification only mode</p> <p>When this operating mode is enabled, the device dehumidifies the room. This function is particularly useful in midseason, namely in those days (as for instance rainy days) when the temperature is pleasant all round, but excess moisture causes a sense of unease. In this operating mode, there is no need to set the room temperature or fan speed, as the fan circulates steadily at minimum speed. In this mode, it is normal for the device to function intermittently.</p>
	<p>Ventilation only mode</p> <p>When you enable this function, the compressor remains inoperative and the device does not adjust the temperature or the humidity of the air in the room. THE MODE allows you to set the fan speed</p>
	<p>Heating only mode</p> <ul style="list-style-type: none"> When this operating mode is enabled, the device heats the room.
	<ul style="list-style-type: none"> You can set the temperature between 16 and 31 °C and if the temperature is higher than room temperature, after three minutes (at the most) the compressor goes off and the appliance begins to provide heat.
	<p>Night comfort key</p> <p>With the device switched on and the cooling or heating mode selected, pressing this key allows you to perform multiple functions in order to maximise the quietness of the device, saving on electricity and optimally adjusting the temperature for night comfort.</p> <p>In this mode the fan is set to minimum speed.</p> <p>This function should be activated just before falling asleep.</p> <ul style="list-style-type: none"> In cooling mode, the set temperature is increased by 1 °C after 1 hour and by 1 °C after 2 hours. After the second hour, the temperature setting is not altered any more and after 6 more hours the device shifts to stand-by. In heating mode, the set temperature is decreased by 1 °C after 1 hour and by 1 °C after 2 hours. After the second hour, the temperature setting is not altered any more and after 6 more hours the device shifts to stand-by. <p>This function is not available in the dehumidification only, ventilation only and automatic economy mode, and can be excluded at any time (ideally when you wake up) by pressing the key again.</p> <p>If you simultaneously set the Timer function, the device switches off after the preset time.</p>
	<p>Airflow direction control</p> <p>By pressing the appropriate key, you can set the constant oscillation of the air flow deflector, in which case the symbol on the display is on, or lock it in any position.</p> <p> IMPORTANT: Never force the flow deflector manually to move it. In cooling and dehumidification mode, the flow deflector's position is reset every 30 minutes in order to prevent the formation of dew.</p>
	<p>Fan speed control</p> <p>Repeatedly pressing this key will change the speed with the following sequence: Minimum, Medium, Maximum and Automatic.</p> <p>The higher the set speed, the higher the device's performance (but also the louder the noise). If you set the speed to Automatic (you will notice the 3 speed bars slide on the display), the micro-processor will adjust the speed automatically (the higher the difference between the room temperature and the set temperature, the higher the speed). The speed is reduced automatically as the room temperature gradually reaches the set temperature. In dehumidification only mode and night comfort mode, you cannot adjust the speed, as the unit can work only at low speed.</p>

Key/Display	Operation
	<p>Setting the Timer function</p> <ul style="list-style-type: none"> The device's operating logic allows the user to freely programme when it is to switch on or off.
	<ul style="list-style-type: none"> While the cooler-radiator is on, you can programme it to switch off by pressing the Timer key and then setting the number of hours (from 1 to 24) after which the device is to switch to stand-by. When the cooler-radiator is off, you can programme it to switch on by pressing the Timer key and then setting the number of hours (from 1 to 24) after which the device is to switch on.
	
	<ul style="list-style-type: none"> Next, press the enter key.
	<p>Touch-screen display keylock</p> <ul style="list-style-type: none"> To lock the keys, hold the Timer symbol on the touch-screen display pressed for 3 seconds. The keylock will prevent the user from enabling or disabling any function on the display. The stand-by symbol flashes intermittently every second. To turn off the keylock, press the Timer symbol again for 3 seconds on the touch-screen display. <p> Any selection from the remote control will deactivate the keylock!</p>

Alarms display

In the event of a malfunction, the display shows an alarm code. The device will nonetheless continue to perform certain functions (see OPERATION column).

Alarm displayed	Cause	Operation
E1	Room temperature probe (RT) failure.	It is possible to normally activate the Cooling, Dehumidification and Heating modes.
E2	Internal battery probe IPT failure	It is possible to normally activate the Cooling, Dehumidification and Heating modes.
E5	Indoor fan motor failure	You cannot activate any operating mode.
E7	Lack of communication with the display *	You cannot activate any operating mode.
CP	Presence contact CP open	The unit is enabled only if the contact is closed. Check the connection of the terminals.
 flashing	Incorrect water temperature	In heating mode, the water temperature is below 30 °C
 flashing	Incorrect water temperature	In cooling mode, the water temperature is above 20 °C

Operating the unit if the remote control is not available

If you lose the remote control, the batteries run out or the remote stops working, you can operate the device with the keys on the touch-screen display on-board the machine.

4.4 Troubleshooting

For the user it is important to distinguish any malfunction or performance levels that differ from the system's standard operating values (see technical specifications). The most common problems can be easily solved by the user by performing certain simple tasks (see the Troubleshooting paragraph), while some system alarms require that you contact the Technical Customer Service.

⚠ Please keep in mind that any attempt by unauthorised staff to repair the device automatically voids any form of warranty.

INSTRUCTIONS FOR USE WITH WALL-MOUNTED CONTROL PANEL

5.1 SMART TOUCH wall-mounted electronic control panel with room probe

The wall-mounted control panel ECA649 is a thermostat fitted with temperature probe with the possibility of controlling one or more (up to a maximum of 30) cooler-convector/cooler-radiators in broadcast (with simultaneous data transmission) equipped with electronic control for allowing remote control ECA649 or ESD645.

The control panel has its own memory, therefore no settings will be lost in case of shut-down or power outage.

⚠ Any failure of the individual terminals connected will not be signalled by the wall-mounted panel.

⚠ Thanks to the temperature probe it ensures anti-freeze

safety even when set to stand-by.

⚠ After 20 seconds from the last action the panel brightness will be reduced and on the display will appear the room temperature. Press any key to restore maximum brightness.



5.2 Display

The display also offers information on the statuses and on any active alarms through 8 specific symbols:

A	Automatic operation
	Silent operation
	Maximum ventilation speed
	Night function
	Heating on

	Cooling on
	Supervision on. Flashing with CP presence contact closed.
	Alarm indication (light on)
	Panel off indication
	Resistance enabled indication

5.3 Keys function

You can set the various functions through the 8 backlit keys:

	Temp + allows increasing the set temperature
	Temp - allows decreasing the set temperature
	Heating/Cooling: allows switching between heating and cooling
AUTO	The ventilation speed will be adjusted automatically between a minimum and a maximum value.



	Night function: the ventilation speed is significantly reduced and the set temperature is changed automatically
	Operation at maximum speed: allows setting the maximum ventilation speed
	ON/Stand-By: allows activating or putting the device in stand-by mode.
	Silent operation: allows limiting the ventilation speed by reducing its maximum value.

5.4 General start-up





In order to control the device from the control panel, it first has to be connected to mains. If a main power switch has been installed on the power line, it must be activated. - Start the system by toggling the main switch

5.5 Activation

To activate the device

Key	Operation	Display
	Press the ON stand-by key	From off to on
AUTO 	Select one of the 4 operating modes by pressing the relative key.	

5.6 Heating / cooling operating mode set-up

Key	Operation	Display
	Press the Heating / Cooling key for about 2 seconds to switch between heating and cooling operating modes; the selection is shown by 2 heating on or cooling on symbols that will light up.	
	In heating, the symbol is alight when the setpoint is higher than the room temperature, both are switched off when the setpoint is lower.	
	In cooling, the symbol is alight when the setpoint is lower than the room temperature, both are switched off when the setpoint is higher.	
	In 4-pipe versions provided with automatic cooling/heating regulation system if the 2 symbols are switched on at the same time it means that the setpoint has been reached (neutral band).	

5.7 Stand By

Key	Operation	Display
	Press the ON stand-by for about 2 s: When the device is in "stand-by" status (no function) there are no light signals on the display.	Off

When the control is in this operating mode, the anti-freeze safety is secured. If the room temperature falls below 5 °C the hot water solenoid valve outputs and boiler consent are activated.

5.8 Temperature selection

Key	Operation	Display
	Use the two increase and decrease keys to set the desired room temperature displayed on the 3 digit display.	20.5



The adjustment range goes from 16 to 28 °C, with a resolution of 0,5 °C, but the system also allows the out of range values 5°C and 40°C (except in automatic mode). The control is very precise, set it to the desired value and wait for it to run the adjustment based on the actually detected room temperature. These values should be set only for short periods of time, after which you must adjust the selection to an intermediate

5.9 Automatic operation

Key	Operation	Display
AUTO	Hold the AUTO key. The function activation will be signalled by the relative symbol on the display	A



The ventilation speed will be adjusted automatically between point based on an algorithm type PI. a minimum and a maximum value, based on the actual distance between the room temperature and the pre-set set-

5.10 Silent operation

Key	Operation	Display
	Hold the Silent key. The function activation will be signalled by the relative symbol on the display	



The ventilation speed is limited at a more reduced maximum value.

5.11 Night function

Key	Operation	Display
	Hold the Night function key. The function activation will be signalled by the relative symbol on the display	

By selecting this operating mode the ventilation speed is significantly reduced and the set temperature is changed automatically as follows:
 - after 2 hours in heating function;
 - increased by 1° C after one hour and by another degree after 2 hours in heating function;
 - decreased by 1° C after one hour and by another degree

5.12 Operation at maximum ventilation speed

Key	Operation	Display
	Hold the Max Operation key. The function activation will be signalled by the relative symbol on the display	

In this operating mode, you will immediately obtain maximum thermal and acoustic comfort. power output both in heating and in cooling. After reaching the desired room temperature you should select one of the other 3 operating modes to increase the

5.13 Key locking

Key	Operation	Display
+	Press both keys + and - at the same time for 3 seconds to activate the local lock up of all keys, the confirmation is represented by the text bL appearing on the display.	bL
-	The user will not be able to perform any adjustment and the text bL appears every time a key is pressed. Repeat the sequence to unlock the keys.	

5.14 Minimum brightness reduction

After 20 seconds from the last action the panel brightness display completely. will be reduced to increase the comfort during night use and on the display will appear the room temperature. If this level of brightness still bothers you you can turn off the

Key	Operation	Display
+	With the panel off press the + key for 5 seconds until the text 01 appears on the display. Use the - key to bring the value to 00 and wait 20 seconds to check for the correct configuration.	00

5.15 Deactivation

Key	Operation	Display
	Press the ON stand-by for about 2 s: When the device is in "stand-by" status (no function) there are no light signals on the display.	Off

The control ensures anti-freeze safety even when set to stand-by.

5.16 Room temperature probe offset adjustment

In some cases the detected values might not represent the actual deviations from the room temperature using a reliable real temperature due to the fact that the temperature probe tool!

is located in the lower section of the device.

Use this function to adjust the measured value shown on the display within a range of +/- 10 °C in steps of 0.1 °C.

Use this adjustment carefully and only after having found

Key	Operation	Display
	With the panel off hold the - key for 5 seconds to access the menu from which you can adjust (using the + and - keys) from -10 to +10 K in 0.1 K steps. After 20 seconds from the last action performed the panel turns off and the setting is saved.	00.0



5.17 Long term shut-down

For seasonal shut-downs or holidays proceed as follows:

- Disable the device.
- Set the main system switch to Off.

 The anti-freeze function is not on.

5.18 Error signals

Error	Display
Room temperature probe failure (located inside the thermostat).	 E1
Failure or connection of a double remote room probe on one of the two connected cooler-radiators.	 E2

5.19 Electronic board with continuous modulation for remote thermostat connection

The electronic board for remote control allows the control of all cooler-radiator functions from the wall-mounted ECA649 control panel.

You can connect to a remote command up to 30 cooler-radiators that will be controlled in broadcast (with simultaneous commands to all cooler-radiators).

It can be installed on all versions, the board has a green LED indicating the status and any faults.

The main operating parameters, the setpoint and the room temperature are transmitted from the wall-mounted remote

control panel ECA649 to all connected terminals in the network, ensuring smooth operation.

For cooler-radiators use please refer to the instructions of this control panel.

The 10 kΩ water temperature probe located in the device battery can manage the minimum in heating (30 °C) and maximum in cooling (20 °C) functions.

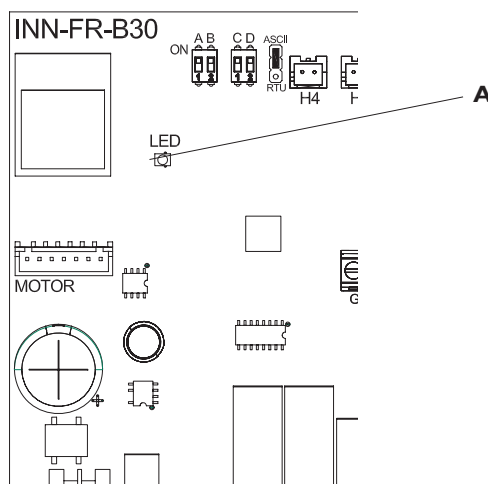

5.20 LED Signals (ref. A)

	Green Led: Signals the functioning of the device. Flashes in case of faults.		LED off: device stopped or not powered.
--	--	--	---

Error signals

Error	Display
Communication error: The board is provided with a function that allows continuous information exchange on the serial line with the wall-mounted control panel ECA649. If it is missing for more than 5 minutes the relative error is displayed and the device is deactivated.	6 flashes + pause
Fan motor fault (for example jamming due to foreign bodies or fault in the rotation sensor).	2 flashes + pause
Water temperature probe failure. In this case make sure the probe has 10 kΩ.	3 flashes + pause
Unmet water request detected by H2 probe (over 20 °C in cooling, below 30 °C in heating). The fan will stop until the temperature reaches an appropriate value to meet the request*.	1 flash + pause

* If after powering the equipment the board detects the water probe, the start-up will take place with minimum and maximum water temperature thresholds. The board can also operate without a probe, case in which the fan stop thresholds will be ignored.

ROUTINE MAINTENANCE

6.1 Maintenance

Routine maintenance is essential to keep the cooler-radiator **filomuro** always efficient, safe and reliable (for other tasks) by our Technical Customer Service, which is qualified for such tasks and which can also be performed over time. Routine maintenance can be performed every six months (for certain tasks) and once a year supply original spare parts, if necessary.

6.2 External cleaning

- ⚠ Disconnect the unit from the power supply before each cleaning and maintenance intervention by setting the main power supply switch to off.
 - ⚠ Do not use abrasive sponges or abrasive or corrosive detergents as you might damage the painted surfaces.
 - ⚠ Wait for the components to cool down in order to avoid any burns.
- Clean the external surfaces of the cooler-radiator **filomuro** using a soft cloth dampened with water.

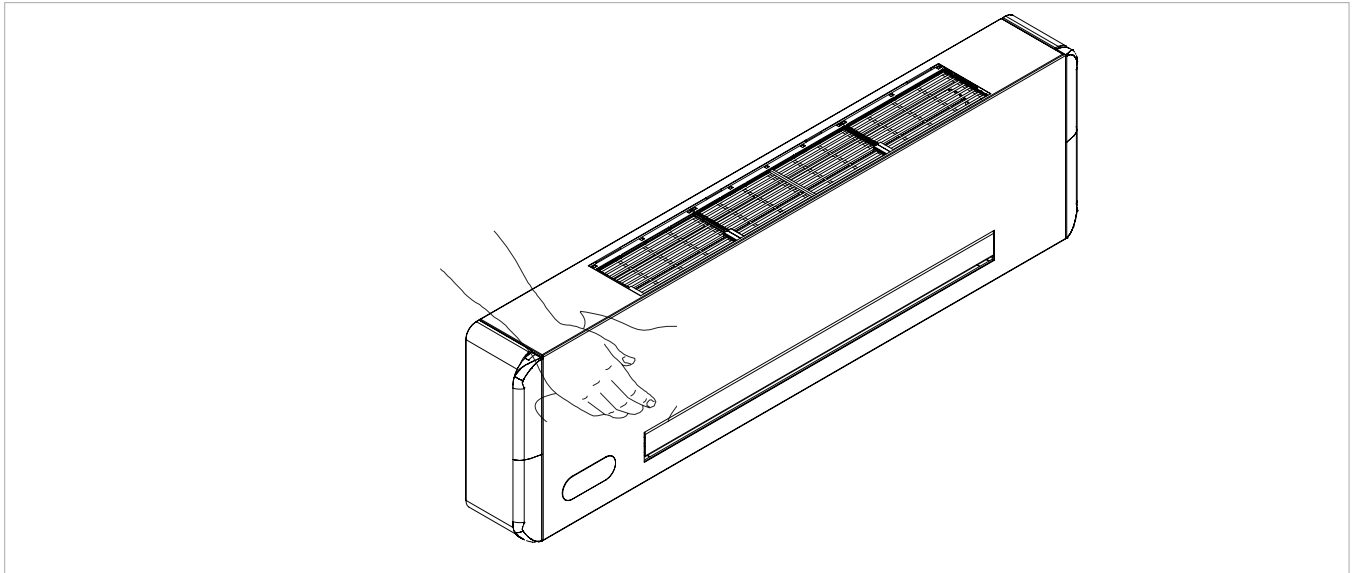

6.3 Cleaning the air suction filter

After prolonged operation and so as to factor the concentration of impurities in the air, or when you plan to restart the system after prolonged disuse, proceed as follows.

Extraction of filter cells

- Remove the filter cells by lifting them slightly and turning them until they come out of their housing;
- Remove the filter by pulling it horizontally and upwards.

A	Filter
B	Filter removal

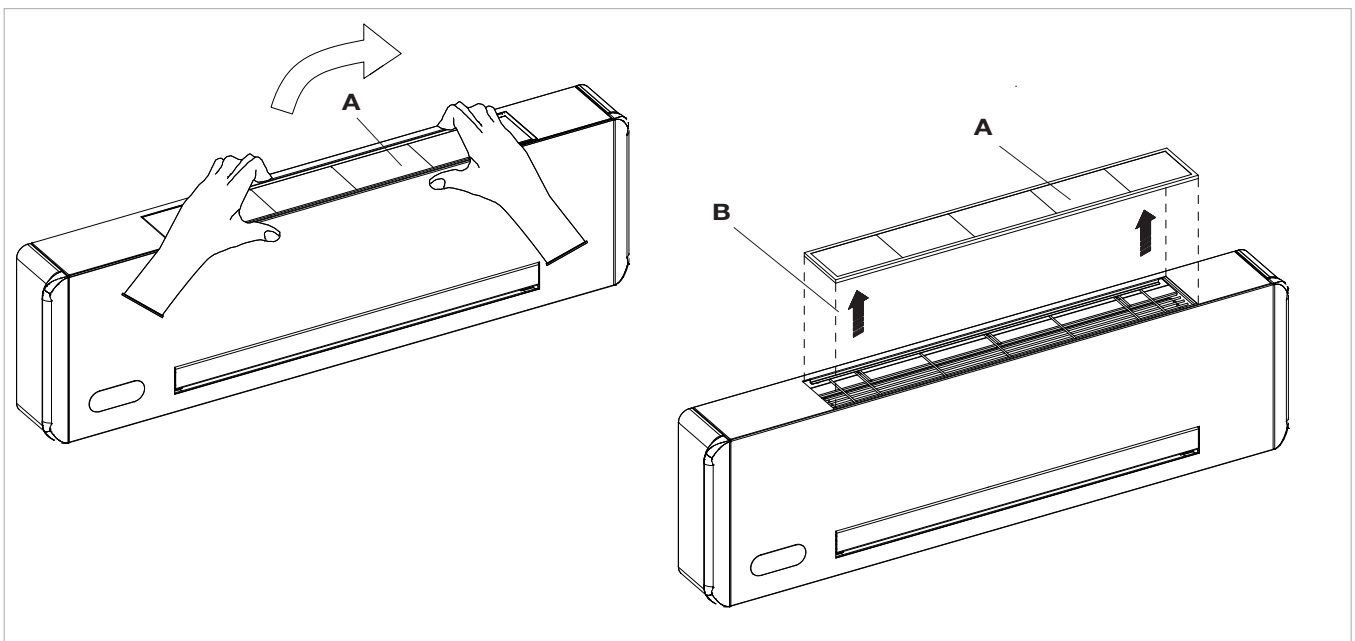

Filter media cleaning

- suction the dust from the filter using a vacuum cleaner
 - wash the filter with running water without using any detergents or solvents and then let it dry.
 - Remount the filter on the cooler-radiator, paying particular attention to introduce the lower flap in its housing.
- ⊘ It is forbidden to use the device without its mesh filter.
 - ⚠ The device features a safety switch that prevents the fan from starting if the mobile panel is incorrectly positioned or missing.
 - ⚠ After filter cleaning check if the panel is properly mounted.

A	Filter

--	--

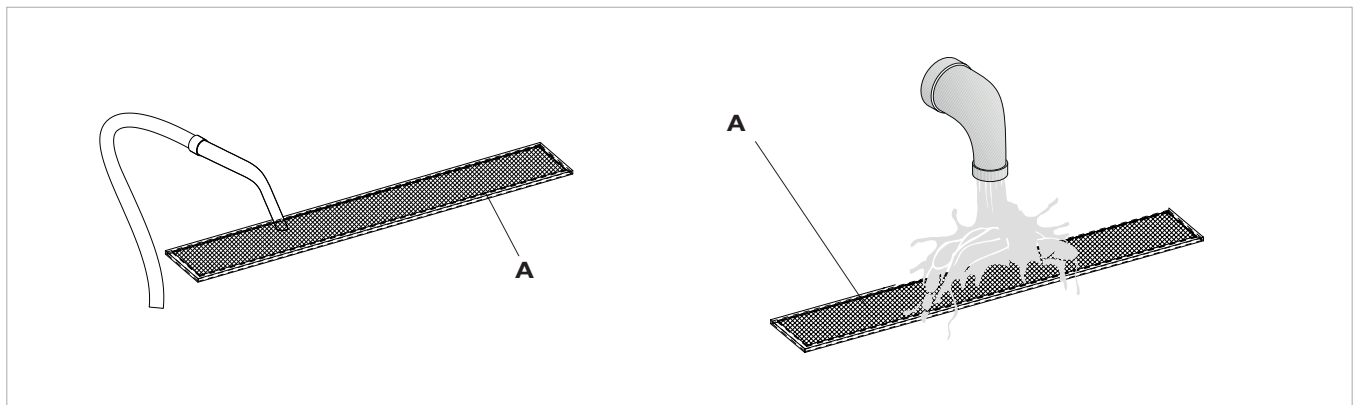

6.4 Suggestions for power saving

- Keep the filters clean;
- keep the doors and windows of the locations fitted with air conditioning systems closed as much as possible;
- during summer limit as much as possible the entry of direct sun rays in the rooms fitted with air conditioning systems (use curtains, blinds, etc.).

TROUBLESHOOTING

7.1

- ⚠ In case of water leaks or abnormal operation, disconnect the device from power supply immediately and close the water taps.
 - The ventilation does not start even if the water circuit is filled with hot or cold water.
 - The device is losing water in heating mode.
 - The device is losing water in cooling mode.
- ⚠ Should you encounter any of the anomalies below, avoid taking actions on your own and contact immediately an authorised technical support centre or qualified staff.
 - The device generates excessive noise.
 - There is dew on the front panel.

7.2 Troubleshooting table

The interventions must be carried out by a qualified installer or by a specialised support centre.

Effect	Cause	Solution
The ventilation is delayed with respect to the new temperature or function settings.	The circuit valve requires a certain time to open and therefore to make the hot or cold water circulate inside the device.	Wait 2 or 3 minutes to allow the circuit valve to open.
The device does not activate the ventilation.	Cold or hot water is missing from the system.	Make sure the boiler or the water cooler are on.
The ventilation does not start even if the water circuit is filled with hot or cold water.	The hydraulic valve stays closed	Demount the body of the valve and check if the water circulation is restored. Check the valve operation feeding it separately to 230 V. If you were to turn, the problem may be in the electronic control.
	The ventilation motor is jammed or burnt.	Check the motor windings and check if the fan rotates freely.
	The wirings are not correct,	Check all wirings.
The device is losing water in heating mode.	Leaks at the hydraulic connections of the system.	Check the leak and tighten the connections.
	Leaks at the valves unit.	Check the condition of the gaskets.
There is dew on the front panel.	Detaches thermal insulation.	Check the correct positioning of the thermal and acoustic insulations paying particular attention to the front one located on top of the finned coil.
There are water drops on the air vent.	High humidity conditions (>60%) might generate condensation, especially at minimum ventilation speeds.	As soon as the level of relative humidity drops, the phenomena disappears. However, a few water drops falling inside the device will not cause any malfunction.
The device is losing water in cooling mode.	The condensate tray is clogged.	Slowly pour a bottle of water in the lower section of the battery to check the drainage; if necessary clean the tray and/or improve the slope of the drain pipe.
	The condensate discharge pipe does not have the slope required for correct drainage.	
	The connection pipes and the valves unit are not well insulated,	Check the pipes insulation.
The device generates excessive noise.	The fan touches the structure.	Check if the filters are dirty and clean them if necessary
	The fan is unbalanced.	The unbalancing generates excessive machine vibrations: replace the fan.
	Check if the filters are dirty and clean them if necessary	Clean the filters



INNOVA s.r.l.
Fraz. Strada, 16 - 38085 PIEVE DI BONO (TN) - ITALY
tel. +39.0465.670104 fax +39.0465.674965
info@innovaenergie.com

N273110A - Rev. 03