

SAMSUNG

FLOOR STAND TYPE AIR CONDITIONER

Basic : AF55JV1MAEE

Model : AC048KNPPCC / AC048KXQPCC
AC036KNPPCC / AC036KXQPCC
AC140KNPDEH / AC140KXADGH
AC100KNPDEH / AC100KXADEH
AC048KNPDEC / AC048KXADGC
AC036KNPDEC / AC036KXADEC

Model Code : AC048KNPPCC/MG AC048KXQPCC/MG
AC036KNPPCC/MG AC036KXQPCC/MG
AC140KNPDEH/EU AC140KXADGH/EU
AC100KNPDEH/EU AC100KXADEH/EU
AC048KNPDEC/TL AC048KXADGC/TL
AC036KNPDEC/TL AC036KXADEC/TL
AC036KNPDEC/SV AC036KXADEC/SV

SERVICE *Manual*

AIR CONDITIONER



AC048KNPPCC
AC036KNPPCC
AC140KNPDEH
AC100KNPDEH
AC048KNPDEC
AC036KNPDEC



AC048KXQPCC
AC036KXQPCC
AC140KXADGH
AC048KXADGC



AC100KXADEH
AC036KXADEC

CONTENTS

1. Precautions
2. Product Specifications
3. Disassembly and Reassembly
4. Troubleshooting
5. PCB Diagram
6. Wiring Diagram
7. Reference Sheet

Contents

1. Precautions	1-1
1-1 Precautions for the Service	1-1
1-2 Precautions for the Static Electricity and PL	1-1
1-3 Precautions for the Safety	1-1
1-4 Others	1-1
2. Product Specifications	2-1
2-1 The Feature of Product	2-1
2-1-1 Features	2-1
2-1-2 Changes in comparison to basic model	2-2
2-2 The Comparative Specifications of Product	2-3
2-3 Accessory and Option Specifications	2-5
2-3-1 Filter.....	2-5
2-3-2 Accessory.....	2-5
3. Disassembly and Reassembly	3-1
3-1 Indoor Unit	3-2
3-2 Outdoor Unit	3-10
4. Troubleshooting	4-1
4-1 Indoor Display Error and Check Method	4-1
4-1-1 Indoor unit LED display at error detecting	4-1
4-2 Outdoor Trouble shooting	4-2
4-3 Troubleshooting by symptoms	4-5
4-3-1 Communication error after finishing tracking (E202).....	4-5
4-3-2 Outdoor's service valve(Clog).....	4-6
4-3-3 No Power(completely dead) - Initial diagnosis.....	4-7
4-3-4 E102 : Communication error between indoor and outdoor unit E201 : Unit quantity miss matching between Indoor and Outdoor E202 : Abnormal state, no communication between Indoor and Outdoor Main PCB E203 : 1 min Time out of communication error(Main↔Inverter)	4-11
4-3-5 External Sensor Error (Error Code: E221, E231, E251, E320)	4-12
4-3-6 E403 : Freezing control causes comp. down	4-13
4-3-7 E416 : Dischage temperature sensor error.....	4-14
4-3-8 E440, E441 : Abnormal outside temperature halts operation of the compressor.....	4-15
4-3-9 Outdoor unit BLDC Fan1 or Fan2 error (E458 : Fan1 error, E475 : Fan2 error)	4-16

Contents

4-3-10 E461: Compressor start error	
E467: Compressor wire missing error	4-17
4-3-11 E462 : Current protection control causes comp. down	
E484 : PFC overload error	4-18
4-3-12 E463 : OLP protection control caused comp. down	4-19
4-3-13 E464 : O.C. (Over Current) error.....	4-20
4-3-14 E466: DC Link Over voltage/ Low voltage error.....	4-21
4-3-15 Pipe Blocking Error (Error Code: E422)	4-22
4-3-16 The others	4-23
4-3-17 Setting an indoor unit installation option	4-24

5. PCB Diagram **5-1**

5-1 Indoor unit	5-1
5-1-1 Main PCB	5-1
5-1-2 Power PCB	5-3
5-1-3 Panel PCB	5-4
5-2 Outdoor unit	5-5
5-2-1 Main PCB Diagram	5-5
5-2-2 Inverter PCB	5-6
5-2-3 EMI PCB	5-10

6. Wiring Diagram **6-1**

6-1 Indoor unit	6-1
6-2 Outdoor unit	6-2

7. Reference Sheet **7-1**

7-1 Index for Model Name	7-1
7-2 Refrigerating Cycle Diagram	7-2

1. Precautions

1-1 Precautions for the Service

- **Use the standard parts when replacing the electric parts.**
 - Confirm the model name, rated voltage, rated current of the electric parts.
- **Repair the disconnection of HARNESS securely when repairing the break down.**
 - If there is any connection error, it causes an abnormal noise and incorrect operation.
- **In case that you assemble or disassemble the products with laying it on the side, do work on the work cloth.**
 - If not, the exterior of products can be scratched.
- **Remove dust and foreign materials from harness, connection part, and inspection part thoroughly when repairing the break down.**
 - It protects the danger of fire such as tracking and short.
- **Tighten tightly the service valve of outdoor unit and the cap of charging valve with a monkey spanner.**
- **Check the assembly status of parts after repairing the break down.**
 - It should be same as the status before repairing.

1-2 Precautions for the Static Electricity and PL

- **As the PCB power terminal has a weakness for the static electricity, pay attention to it during the repair and measurement.**
 - Work with insulation gloves during the repair and measurement of PCB.
- **Check the distance between the product and the other electronic appliances such as TV, video, and audio. It should be over 2m.**
 - If not, it causes a bad picture quality or a noise.
- **Repairing the products by consumer should be strictly prohibited.**
 - There is a danger of electric shock or fire due to incorrect disassembly.

1-3 Precautions for the Safety

- **Do not pull any electric wires and do not touch an auxiliary power switch with a wet hand.**
 - There is a danger of electric shock or fire.
- **In case any wire or power plug has been damaged, replace it to eliminate any possible danger.**
- **Do not bend the power cord by force and do not put any heavy object on the power cord.**
 - There is a danger of electric shock or fire.
- **Do not use multi socket.**
 - There is a danger of electric shock or fire.
- **Ground the product if necessary.**
 - Be sure to ground the product if there is any danger of electric leakage due to water or moisture.
- **Be sure to turn off the auxiliary power switch or pull out the power plug during replacement or repair of electric parts.**
 - There is a danger of electric shock.
- **In case the product will not be in use for a long time, the battery of remote control should be kept separately.**
 - Leakage of inside fluid can cause break down of remote control.

1-4 Others

- **Never store or load the air conditioner upside down or sideways to prevent the damage to the compressor.**
- **Young children or infirm persons should be always supervised when they use the air conditioner.**
- **Max current is measured according to IEC standard for safety.**
- **Current is measured according to ISO standard for energy efficiency.**
- **When installing, make sure there is no leakage. When recovering the refrigerant, ground the compressor first before removing the connection pipe. If the refrigerant pipe is not properly connected and the compressor works with the service valve open, the pipe inhales the air and it makes the pressure inside of the refrigerant cycle abnormally high. It may cause explosion and injury.**
- **Pump Down Procedure (When removing the product)**
 - Turn on the air conditioner and select Cool mode to run the compressor for 3 minutes.
 - Release the valve caps on High and Low pressure side.
 - Use L wrench to close the valve on the high pressure side.
 - Approximately 2 minutes after, close the valve on the low pressure side.
 - Stop operation of the air conditioner.
 - Disconnect the pipes.

2. Product Specifications

2-1 The Feature of Product

2-1-1 Features

- **Strong Turbo/convenient long-distance operation**

Quicker and more consistent air cooling/warming is guaranteed by turbo operation that provides strong cooling/warming for 30 minutes or by long-distance operation that ensures cooling/warming even in places a long way from the air conditioner.

- **Stylish, high quality design**

Neat and luxurious style boasts high-quality interior design that fits naturally into any place.

- **Compact Remote Controller**

A small hand-size remote control makes it even easier to use.

- **Long Piping(Length & Height)**

It can give the benefit to the installers and arises the reliability of the air conditioner.

- **Long Ambient Operation(In Low Temperature)**

It can arise the reliability and the capacity of the air conditioner, especially operated in low temperature.

- **Eco-friendly Product (Lead-Free, RoHS, WEEE)**

- **High Performance & Energy Saving**

With the advanced BLDC inverter technology, it makes a room cool with highly energy saving and arises the efficiency of air conditioner.

2-1-2 Changes in comparison to basic model

Changed part	Changed item and feature	Basic	After changed
Indoor Unit	Wi-Fi Function added.		
Outdoor Unit (AC048KXQPCC AC036KXQPCC AC140KXADGH AC048KXADGC)	Inverter controller changed.		
Outdoor Unit (AC100KXADEH AC036KXADEC)	-	-	

2-2 The Comparative Specifications of Product

Item	Development Model							Basic Model	
	AC048KNPPCC AC048KXQPC	AC036KNPPCC AC036KXQPC	AC140KNPDEH AC140KXAPGH	AC100KNPDEH AC100KXAPEH	AC048KNPDEC AC048KXAPGC	AC036KNPDEC AC036KXADEC	AF55JV1MAEEN AF55JV1MAEEX		
Design	Indoor Unit								
	Outdoor Unit								
	Wireless Remote Controller	 DB93-15883B		 DB93-15883B		 DB93-15883B		 DB93-14643X	
Performance	Cooling (T1) [Btu/h or W]	15 000/48 000/60 000	12 300 / 36 000 / 45 700	4 200 / 13 400 / 16 700	3 500 / 10 000 / 12 300	3 600 / 14 000 / 16 700	3 400 / 10 000 / 13 000	15000/48000/60000	
	Cooling (T3) [Btu/h]	42 000	32 000	-	-	-	-	42000	
	Heating [W]	-	-	4 000 / 15 500 / 20 000	4 200 / 11 200 / 14 000	-	-	-	
Power Consumption	Cooling (T1) [W]	890 / 4,050 / 6,600	1,100 / 3,030 / 4,000	900 / 4,320 / 5,900	1,100 / 3,700 / 4,900	820 / 5,040 / 5,600	880 / 3,270 / 4,900	890/3930/6600	
	Cooling (T3) [W]	4,920	3,700	-	-	-	-	4950	
	Heating [W]	-	-	700 / 4,500 / 6,600	900 / 3,390 / 4,500	-	-	-	
EER/COP	Cooling (T1) [Btu/h-W or W/W]	11.85	11.88	3.10	11.88	2.78	3.06	12.21	
	Cooling (T3) [Btu/h-W]	8.54	8.65	-	8.65	-	-	8.48	
	Heating [W/W]	-	-	3.44	-	-	-	-	
	SEER [W/W]	-	-	-	A+ (5.8)	-	-	-	
	SCOP [W/W]	-	-	-	A+ (4.1)	-	-	-	
Operating Current	Voltage / Frequency	230V, 60Hz		3Φ 380-415V, 50Hz	220-240V, 50Hz	3Φ 380-415V, 50Hz	220-240V, 50Hz	230V, 60Hz	
	Cooling (T1) [A]	4.7 / 18.2 / 28.5	5.7 / 13.5 / 18.3	1.9 / 6.8 / 9.5	4.3 / 16.4 / 23.2	1.6 / 7.8 / 9.0	4.4 / 14.4 / 22.5	4.7/17.2/28.5	
	Cooling (T3) [A]	21.3	16.7	-	-	-	-	21.1	
	Heating [A]	-	-	1.4 / 6.7 / 10.7	4.1 / 14.9 / 20.5	-	-	-	
Noise	Indoor Unit [dBA]	51 / -	47 / -	51 / 51	47 / 47	51 / -	45 / -	-	
	Outdoor Unit [dBA]	55 / -	51 / -	53 / 54	53 / 55	53 / -	51 / -	-	
Size	Net Dimension (WxHxD)	Indoor Unit [mm]	610*1850*400	610*1850*400	610*1850*400	610*1850*400	610*1850*400	610*1850*400	
		Outdoor Unit [mm]	940*1420*330	940*1210*330	940*1210*330	940*998*330	940*1210*330	940*998*330	940*1420*330
	Shipping Dimension (WxHxD)	Indoor Unit [mm]	705*1963*493	705*1963*493	705*1963*493	705*1963*493	705*1963*493	705*1963*493	705*1963*493
		Outdoor Unit [mm]	995*1597*426	995*1388*426	995*1388*426	995*1096*426	995*1388*426	995*1096*426	995*1597*426
Weight	Net Dimension	Indoor Unit [kg]	46	46	46	42	46	42	
		Outdoor Unit [kg]	92	81	91	72	81	69	90
	Shipping Dimension	Indoor Unit [kg]	52	52	52	49	52	49	51
		Outdoor Unit [kg]	102	90	101	77	90	74	100
Harness Specifications	Indoor Fan Motor	FMAF031SSA	FMAF031SSA	FMAF031SSA	FMC9731SSC	FMAF031SSA	FMC9731SSC	FMAF031SSA	
	Compressor	UG5T450FXAJX	UG5TK1450FJX	UG5TK1450FJX	UG8T300FUBJU	UG5TK1450FJX	UG8T300FUBJU	UG5T450FXAJX	
	Outdoor Fan Motor	DAO335130ZRD		ATB125FGA	DAO335130ZRD		DAO335130ZRD	DAO335130ZRD	
Piping	High Pressure	3/8"	3/8"	3/8"	3/8"	3/8"	3/8"	3/8"	
	Low Pressure	3/4"	5/8"	5/8"	5/8"	5/8"	5/8"	3/4"	
Exterior	Display	LED	LED	LED	LED	LED	LED	LED	
	Refrigerant Type	R410A	R410A	R410A	R410A	R410A	R410A	R410A	
	Factory Charging [g]	2600	2400	3500	3000	2900	2400	2600	
	Additional Refrigerant (for every 1m) [g]	30	30	50	50	30	30	30	
	Basic Piping Length [m]	5	5	5	5	5	5	5	
	Max. Piping Length [m]	75	75	75	50	75	50	50	
	Max. Level Difference [m]	30	30	30	30	30	30	30	
	Option Code	01146A-1900D7-278C00-370000	01146A-190096-276900-370000	01146A-1950C7-278C9B-370000	01146A-195085-276470-370000	01146A-1900C7-278C00-370000	01146A-190085-276400-370000	01144A-1900C7-279100-370010	

2-3 Accessory and Option Specifications

2-3-1 Filter

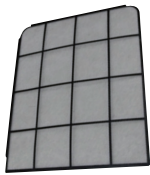
Item	Descriptions	Code-No.	Remark
	Air Filter	DB63-02928B	Basic/ Water Washing

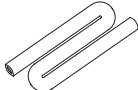

2-3-2 Accessory

Item	Descriptions	Code-No.	Q'ty	Remark
	Manual (AC048/036KNPPCC)	DB68-04872A	1	Indoor Unit
	Manual (AC140/100KNPDEH)	DB68-06271A DB68-06272A	1	
	Manual (AC048/036KNPDEC)	DB68-06270A	1	
	Wireless Remocon	DB93-15883B	1	
	Battery	DB47-90024A	2	
	Holder Remocon	DB61-06087A	1	
	Rubber Cabi Hole	DB73-00195A	1	
	Insulation Tube	DB62-10944A	1	
	Insulation (AC048/036KN*)	DB72-50300A	1	

Item	Descriptions	Code-No.	Q'ty	Remark
	Insulation (AC140/100KN*)	DB72-50300C	1	Indoor Unit
	Holder Top	DB61-40042B	1	
	Screw (L14)	6002-000538	4	
	Screw (L12)	6002-000231	4	
	Rubber leg	DB73-20134A	4	Outdoor Unit
	Drain Plug	DB67-00806A	1	
	CAP Drain	DB63-10355C	3	

3. Disassembly and Reassembly

■ Necessary Tools

Item	Remark
+Screw driver	
Monkey spanner	

3-1 Indoor Unit

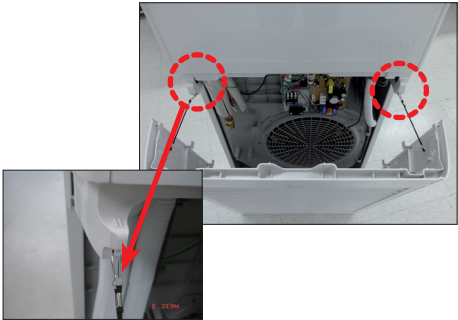
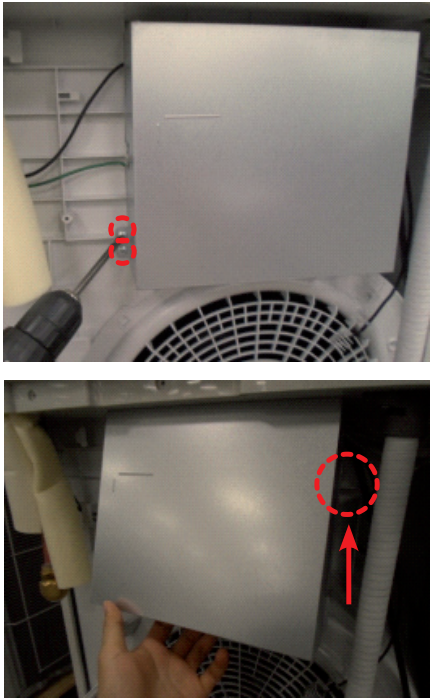

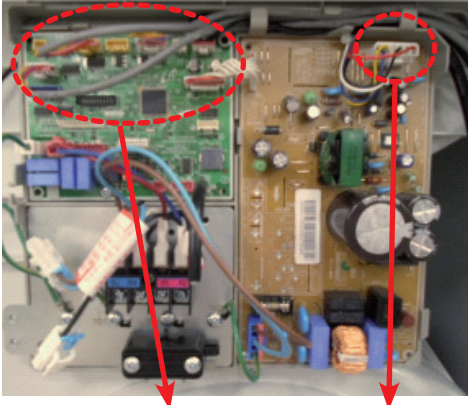
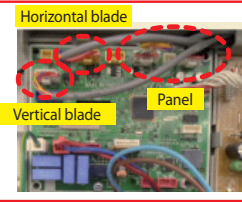
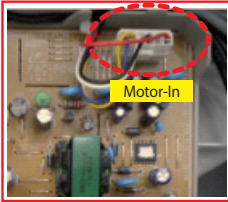
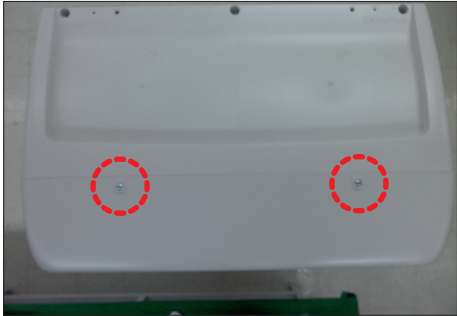
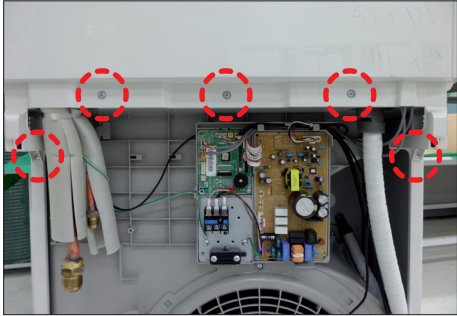
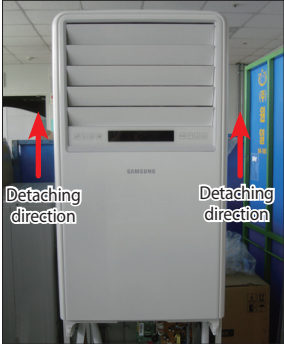

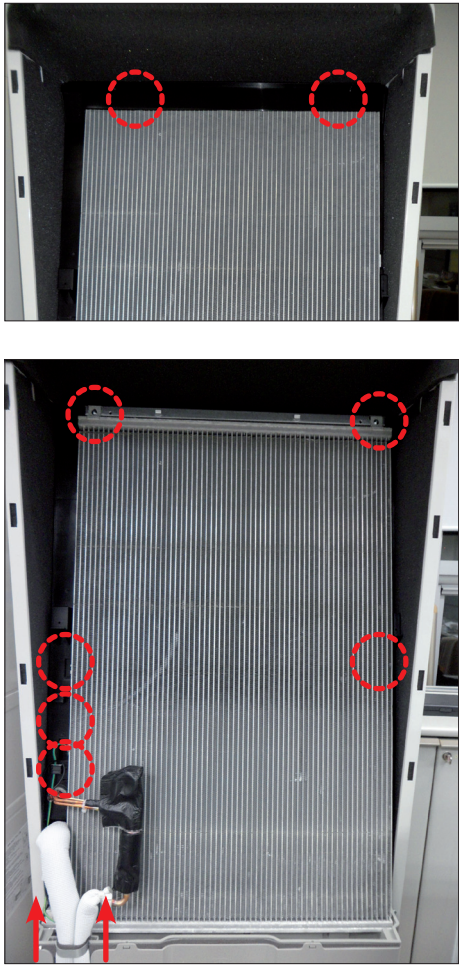
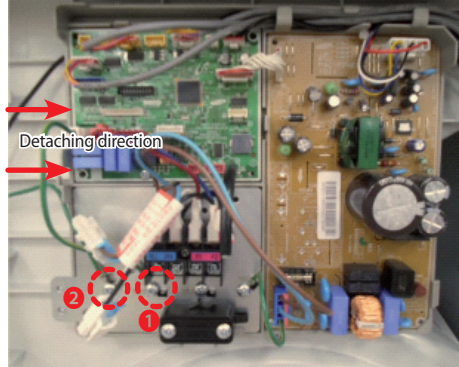
No	Parts	Procedure	Remark
1	Indoor unit	1) Stop the operation of the air conditioner and disconnect the main power supply.	
2	Ass'y Inlet Part	1) Open the Ass'y Inlet and remove the safety clips.	
3	Ass'y Cover Control	1) Loosen one fixing screw of Ass'y Cover Control. (Use +Screw driver) and detach the cover. 2) Lift up the Ass'y Cover Control and detach it by pulling the bottom outward.	

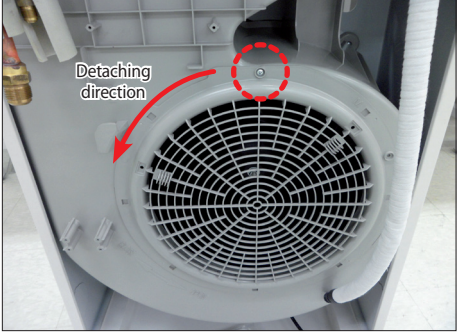
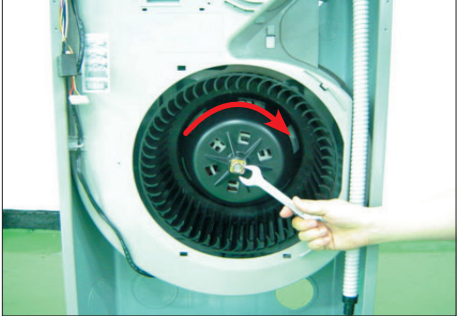
No	Parts	Procedure	Remark
		<p>3) Detach the connectors connected to Panel-Outlet and the Motor Connector.</p>	 <div style="display: flex; justify-content: space-around;"> <div data-bbox="932 698 1174 898">  </div> <div data-bbox="1182 698 1410 898">  </div> </div>
<p>4</p>	<p>Ass'y Panel-outlet</p>	<p>1) Loosen the 7 fixing screws of Ass'y Panel-Outlet and detach the panel outlet by pushing upwards. (Use +Screw driver)</p>	  

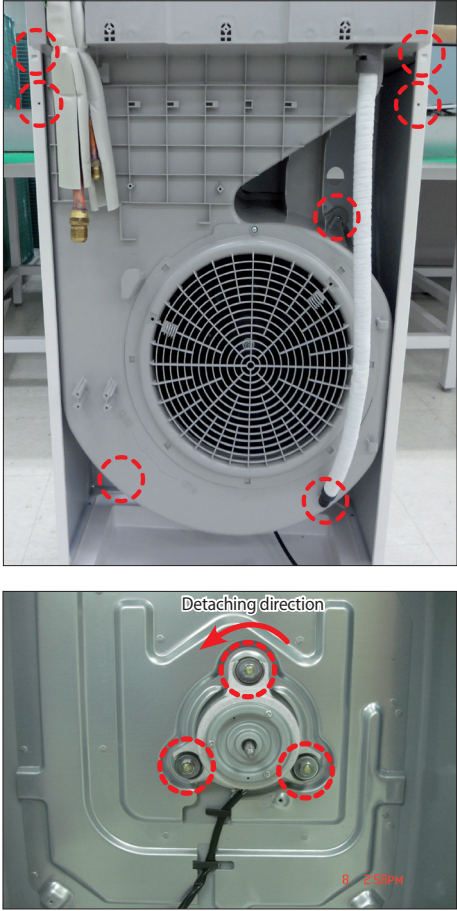
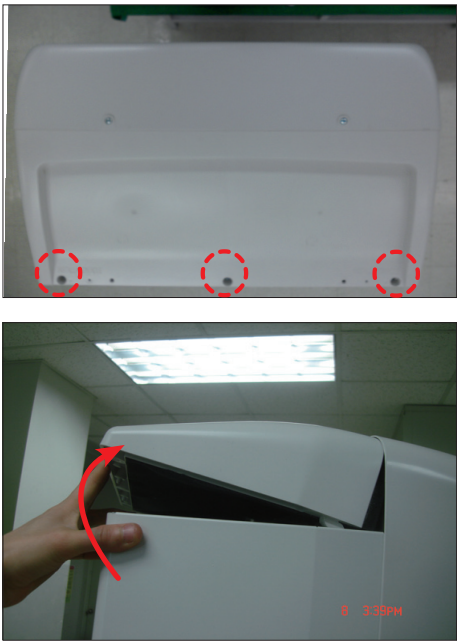
No	Parts	Procedure	Remark
5	Ass'y Eva	<ol style="list-style-type: none"> 1) Loosen the 2 fixing screws of Cover EVA Top and detach the Top. 2) Loosen the 4 fixing screws of EVA. 3) Loosen the grounding screw. 4) Pull out the sensor cable. 5) Pull out the Bracket Pipe upward. 6) Pull the upper part of the Heat Exchanger toward you and lift up the Heat Exchanger to detach. 	
6	Ass'y Control In	<ol style="list-style-type: none"> 1) Loosen the 1 fixing screw of Ass'y Control. 2) Loosen the EVA grounding fixing screw. 3) Detach the Ass'y Control In by pushing it to the right. 	

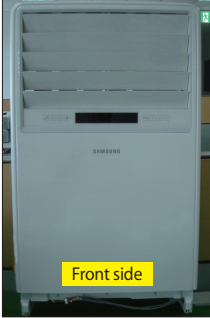
No	Parts	Procedure	Remark
7	Ass'y Blower	<ol style="list-style-type: none">1) Loosen the 1 fixing screw of Guard Fan. (Use +Screw driver)2) Push the Guard Fan in the arrow direction and detach the guard. 3) Loosen the Blower nut clockwise and pull the Blower toward you and detach it. (Use a monkey spanner.)	 

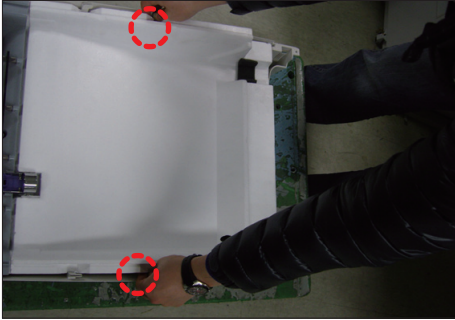
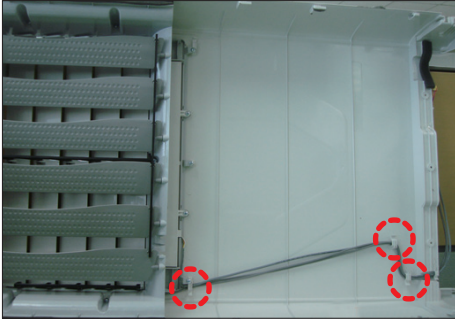

No	Parts	Procedure	Remark
8	Ass'y Motor Blower	<p>1) Loosen the 5 fixing screws of Ass'y Duct Case and detach the case. (Use +Screw driver)</p> <p>2) Loosen the 3 fixing screws of Motor and ground fixing screw. (Use a monkey spanner.) (Remove the connectors before detaching the Motor.)</p>	
9	Cover Top	<p>1) Loosen the 3 fixing screws of Cover-Top and detach the cover. (Use +Screw driver), (Screw : TH type2 M4, L10, BLK)</p> <p>2) Lift up the rear of Cover Top and detach it.</p>	

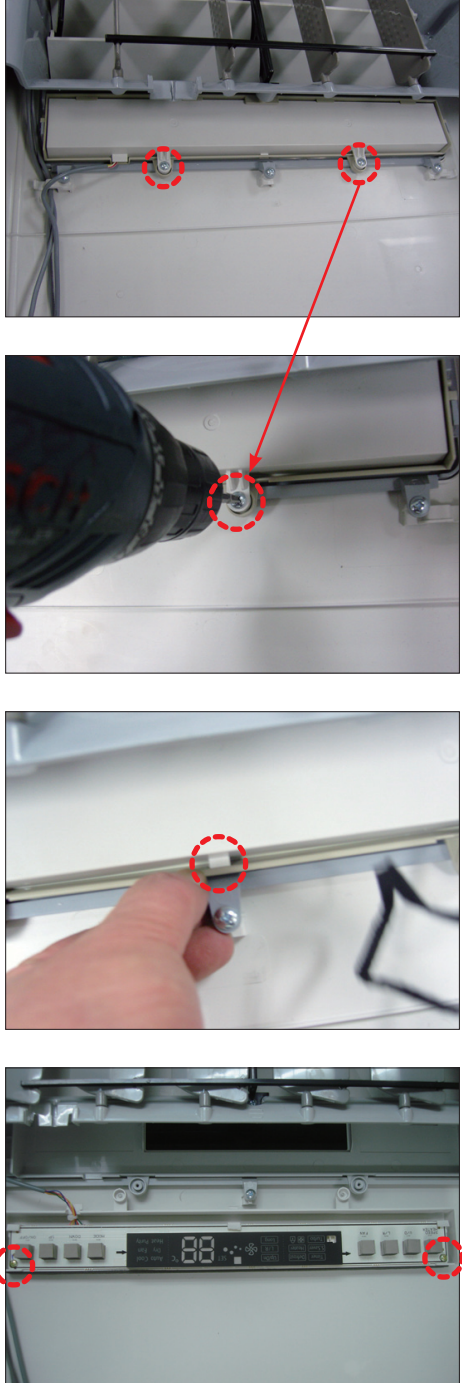

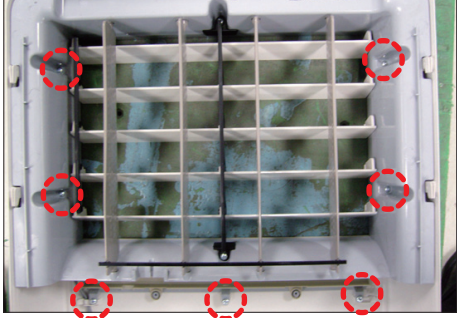
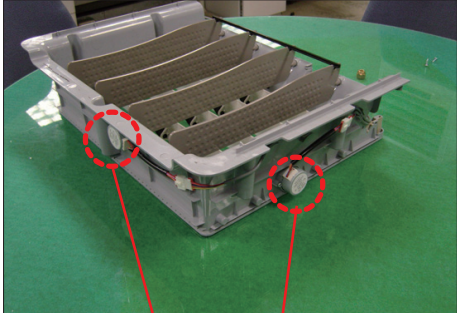
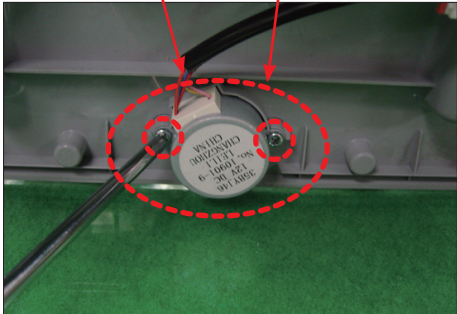
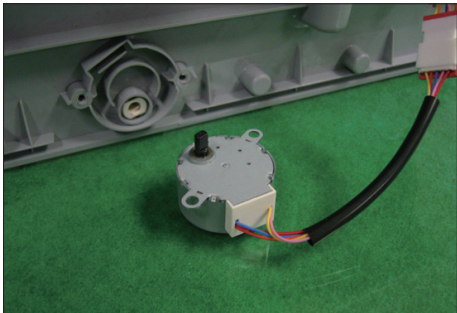
No	Parts	Procedure	Remark
10	Ass'y Panel-Outlet	<p>1) Panel-Outlet</p> <p>2) As you push the 2 hooks on each side of Panel outward, detach the bottom part of Partition by lifting it toward you.</p> <p>3) Detach the wire positioned with Holder Wire.</p> <p>4) Detach the wire positioned with Holder Wire.</p>	    

No	Parts	Procedure	Remark
11	<p>Ass'y Panel-outlet</p> <p>- Seperate Display PBA</p>	<p>1) Loosen the 2 fixing screws of Case Display PBA and detach the case. (Use +Screw driver)</p> <p>2) Unlink the fixing hook placed in the middle of Case Display PBA.</p> <p>3) Loosen the 2 fixing screws of PBA and detach the PBA. (Use +Screw driver)</p>	 <p>The 'Remark' column contains three sequential photographs illustrating the disassembly process. The first photo shows the top of the case with two screws circled in red. The second photo shows a hand unhooking a metal hook from the center of the case, with the hook circled in red. The third photo shows the front panel (PBA) with two screws circled in red.</p>

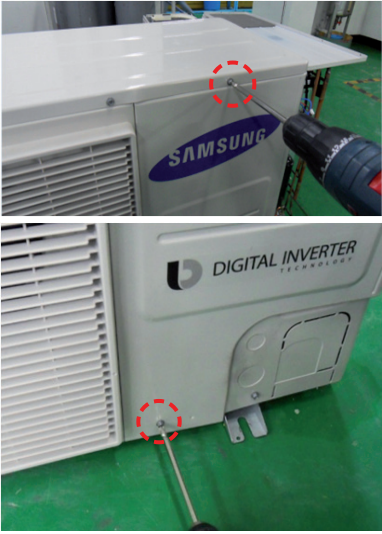
No	Parts	Procedure	Remark
12	Ass'y Panel-outlet - Motor Step	<p>1) Loosen the 8 fixing screws of Holder Blade and detach the holder. (Use +Screw driver)</p> <p>2) Loosen the 2 fixing screws of Step Motor and detach the motor. (Use +Screw driver)</p> <p>3) The detached Step Motor.</p>	   

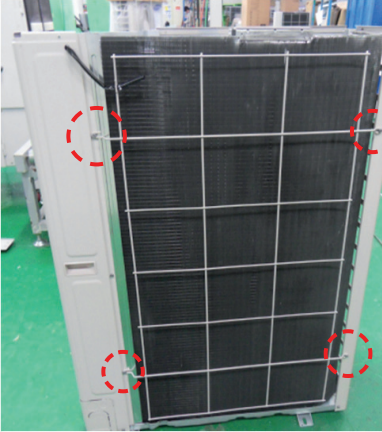
3-2 Outdoor Unit

No	Parts	Procedure	Remark
1	Cabi Front RH	<p>⚠ You must turn off the Power before disassembly.</p> <p>1) Unscrew and remove two mounting screw in the Cabinet Front RH. (Use +Screw Driver)</p>	
2	Cabi Top	<p>1) Unscrew and remove 9 screws on each side of the Cabinet-Top. (Use +Screw Driver)</p>	
3	Cabi Install Front	<p>1) Unscrew and remove 1 screw in the Cabinet-Install Front. (Use +Screw Driver)</p>	
4	Guard Cond	<p>1) Pull the sensor from Guard Cond.</p> <p>2) Unscrew and remove 4 screws in the Guard Cond. (Use +Screw Driver)</p>	

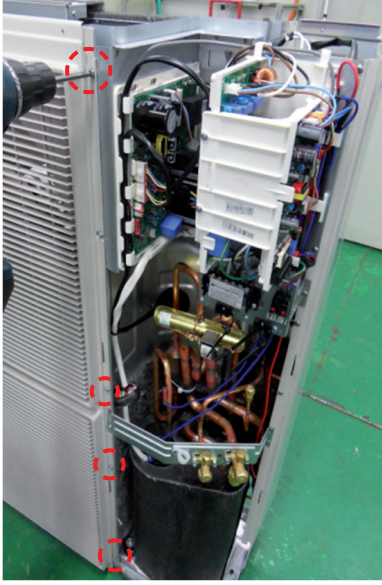
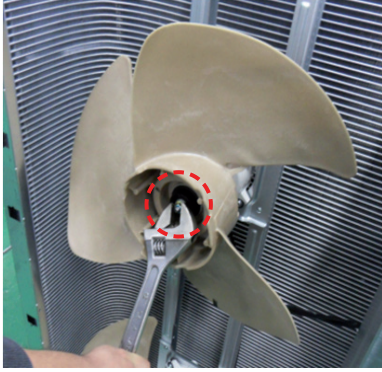
No	Parts	Procedure	Remark
5	Cabi Back RH	1) Pull the sensor from Cabi Back RH. 2) Unscrew and remove 4 screws on each side of the Cabinet Back RH. (Use +Screw Driver)	
6	Cabi Install Back	1) Unscrew and remove 1 screw in the Cabinet-Install Back. (Use +Screw Driver)	
7	Cabi Front LF	1) Unscrew and remove 10 screws in the Cabinet-Front LF. (Use +Screw Driver)	
8	Fan	1) Turn 2 mounting nuts as shown in the picture and remove it. (Use Adjustable Wrench)	

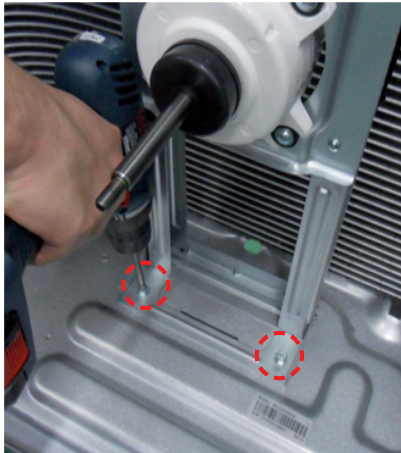
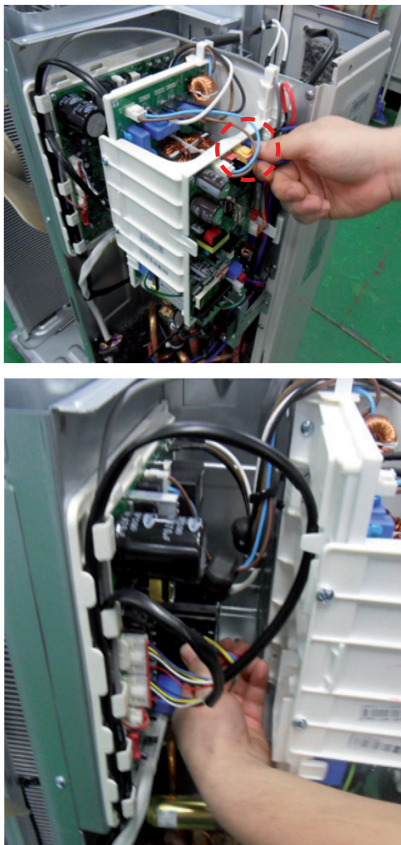
No	Parts	Procedure	Remark
9	Motor	<ol style="list-style-type: none"> 1) Separate the Fan Propeller. 2) Unscrew and remove the 8 Motor mounting screws. (Use +Screw Driver) 3) Disconnect the Motor wire From Ass'y Control Out. 	
10	Bracket Motor	<ol style="list-style-type: none"> 1) Unscrew and remove 2 mounting screws in Bracket Motor. (Use +Screw Driver) 	
11	Control Out	<ol style="list-style-type: none"> 1) Disconnect 4 Connecters From Ass'y Control Out. 2) Unscrew and remove 1 mounting screw in Control Out. (Use +Screw Driver) 3) Separate Ass'y Control Out. 	

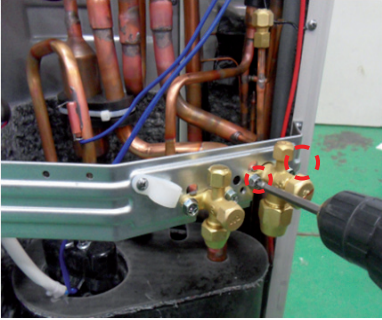
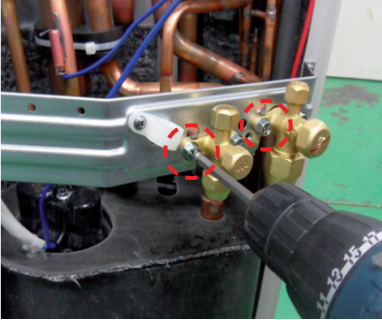
No	Parts	Procedure	Remark
12	Assy 4way Valve	<p>1) Purge the Coolant first.</p> <p>2) Unscrew and remove 2 mounting screws in Service Valve. (Use +Screw Driver)</p> <p>3) Separate the pipe from the Entrance/Exit using a welder.</p> <p>⚠ When removing the compressor, Heat Exchanger, and Pipe, purge the Coolant inside the Compressor completely and remove the pipe with a welding flame.</p>	
13	Assy EEV Valve	<p>1) Unscrew and remove 2 mounting screws in Service Valve. (Use +Screw Driver)</p> <p>2) Separate the pipe from the Entrance/Exit using a welder.</p>	

4. Troubleshooting

4-1 Indoor Display Error and Check Method

4-1-1 Indoor unit LED display at error detecting

- Things to check before diagnosis

Display	Explanation	Check list	Product operation			Diagnosis Method
			Indoor FAN	Outdoor FAN	COMP	
E 101	Indoor and Outdoor unit communication Error	<ul style="list-style-type: none"> ● Check the connection wire. ● Change the Main PCB. 	Operation OFF	Operation OFF	Operation OFF	
E 121	Indoor unit room temperature sensor SHORT/OPEN	<ul style="list-style-type: none"> ● Change the temperature sensor. (Wire type) 	Operation OFF	Operation OFF	Operation OFF	
E 122	Indoor unit Eva_in sensor SHORT/OPEN	<ul style="list-style-type: none"> ● Change the temperature sensor. (Wire type) 	Operation OFF	Operation OFF	Operation OFF	
E 154	Indoor unit Fan motor Error	<ul style="list-style-type: none"> ● Check the connection wire. ● Change the Fan motor. ● Change the Main PCB. <p>※ BLDC Motor is used as Fan Motor, therefore if you connect or disconnect the connector while the power is still on, it may get damaged. Make sure to turn off the power before performing any operation.</p>	Operation OFF	Operation OFF	Operation OFF	
E 162	EEPROM ERROR	<ul style="list-style-type: none"> ● Change PCB. 	Operation OFF	Operation OFF	Operation OFF	
E 163	EEPROM Option Setting Error	<ul style="list-style-type: none"> ● Input option. - Cannot input KEY 	Operation OFF	Operation OFF	Operation OFF	
E 198	Thermal Fuse Error (TERMINAL BLOCK)	<ul style="list-style-type: none"> ● Check the connection wire. 	Operation OFF	Operation OFF	Operation OFF	
E 108	Duplicated address setting error	<ul style="list-style-type: none"> ● Check address setting of Indoor units. 	Operation OFF	Operation OFF	Operation OFF	
E 109	No response error of address from indoor unit	<ul style="list-style-type: none"> ● Check indoor unit's quantity setting in outdoor unit. ● Check electrical connection and setting. 	Operation OFF	Operation OFF	Operation OFF	

4-2 Outdoor Trouble shooting

The table below give indication about self diagnostic routine. Some of error code requires activities exclusively for Authorized Service Center.

Outdoor unit

If an error occurs during the operation, it is displayed on the outdoor unit PCB LED, both MAIN PCB and INVERTER PCB.

No.	Error Code	Meaning	Remarks
1	E108	Error due to repeated address setting(when 2 or more devices has same address within the network)	Check on repeated indoor unit main address
2	E121	Error on indoor temperature sensor of indoor unit(Short or Open)	Indoor unit Room Thermistor Open/Short
3	E122	Error on EVA IN sensor of indoor unit(Short or Open)	Indoor unit EVA_IN Thermistor Open/Short
4	E123	Error on EVA OUT sensor of indoor unit(Short or Open)	Indoor unit EVA_OUT Thermistor Open/Short
5	E153	Error on float switch (2nd detection)	"Indoor unit Float Switch Open/Short Drain Pump operation Check"
6	E154	RPM feedback error of indoor unit	Check on indoor unit indoor Fan operation
7	E162	Outdoor unit EEPROM Read/Write error (H/W)	Check Outdoor EEPROM PBA
8	E163	Outdoor unit EEPROM Read/Write error (Option)	Check Outdoor EEPROM Data
9	E198	Error on thermal fuse of indoor unit (Open)	Thermal Fuse Open Check of indoor unit Terminal Block
10	E201	"Communication error between indoor and outdoor unit(Installation number setting error repeated indoor unit address,indoor unit communication cable error)"	Check indoor quantity setting in outdoor
11	E202	"Communication error between indoor and outdoor unit(Communication error on all indoor unit, outdoor unit communication cable error)"	Check electrical connection and setting between indoor unit and outdoor unit
12	E205	Communication error on all PBA within the outdoor unit C-Box,communication cable error	-
13	E206	E206-C002 : Fan PBA communication error, E206-C003 : INV PBA communication error	-
14	E221	Error on outdoor temperature sensor (Short or Open)	Check Outdoor sensor Open / Short
15	E231	Error on outdoor COND OUT sensor (Short or Open)	Check Cond-Out sensor Open / Short
16	E251	Error on discharge temperature sensor of compressor 1 (Short or Open)	Check Discharge sensor Open / Short
17	E320	Error on OLP sensor (Short or Open)	Check OLP sensor Open / Short
18	E346	Error due to operation failure of Fan2	FAN2 error
19	E347	Motor wire of Fan2 is not connected	FAN2 error
20	E348	Lock error on Fan2 of outdoor unit	FAN2 error
21	E353	Error due to overheated motor of outdoor unit's Fan2	FAN2 error
22	E355	Error due to overheated IPM of Fan2	FAN2 error
23	E378	Error due to overcurrent of Fan2	FAN2 error
24	E386	Over-voltage/low-voltage error of Fan2	FAN2 error
25	E387	Hall IC connection error of Fan2	FAN2 error
26	E389	V-limit error on Fan2 of compressor	FAN2 error
27	E391	Error due to DataFlash of Fan2	FAN2 error
28	E393	Output current sensor error of Fan2	FAN2 error

No.	Error Code	Meaning	Remarks
29	E396	DC voltage sensor error of Fan2	FAN2 error
30	E399	Heat sink temperature sensor error of Fan2	FAN2 error
31	E403	Compressor down due to freeze protection control	Check Outdoor Cond.
32	E404	System stop due to overload protection control	Check Comp. when it start
33	E416	System stop due to discharge temperature	-
34	E422	Blockage detected on high pressure pipe	1. Check if the service valve is open
			2. Check for refrigerant leakage(pipe connections, heat exchanger) and charge refrigerant if necessary
			3. Check if there's any blockage on refrigerant cycle(indoor unit/outdoor unit)
			4. Check if additional refrigerant has been added after pipe extension
35	E425	Reverse phase or open phase	Check whether 3 phase is reversed or opened.
36	E440	Heating mode restriction due to high air temperature	HEATING
37	E441	Cooling mode restriction due to low air temperature	COOLING
38	E446	Error due to operation failure of Fan1	FAN1 error
39	E447	Motor wire of Fan1 is not connected	FAN1 error
40	E448	Lock error on Fan1 of outdoor unit	FAN1 error
41	E452	Error due to ZCP detection circuit problem or power failure	-
42	E453	Error due to overheated motor of outdoor unit's Fan1	FAN1 error
43	E455	Error due to overheated IPM of Fan1	FAN1 error
44	E458	Fan speed error	FAN1 ERROR
45	E461	Error due to operation failure of inverter compressor	-
46	E462	System stop due to full current control	-
47	E463	Over current trip / PFC over current error	Check OLP sensor
48	E464	IPM Over Current(O.C)	IPM
49	E465	Comp. Over load error	-
50	E466	DC-Link voltage under/over error	Check AC Power and DC Link Voltage
51	E467	Error due to abnormal rotation of the compressor or unconnected wire of compressor	Check Comp wire
52	E468	Error on current sensor (Short or Open)	Check Outdoor Inverter PBA.
53	E469	Error on DC-Link voltage sensor (Short or Open)	-
54	E471	Outdoor EEPROM checksum error between MAIN and INVERTER (AC***KXAPNH)	Check Outdoor EEPROM PBA
55	E472	AC Line Zero Cross Signal out	-
56	E473	Comp Lock error	-
57	E474	Error on IPM Heat Sink sensor of inverter 1 (Short or Open)	heck Outdoor Inverter PBA
58	E475	Error on inverter fan 2	FAN2 ERROR
59	E478	Error due to overcurrent of Fan1	FAN1 error
60	E484	PFC Overload (Over current) Error	Check Outdoor Inverter PBA.
61	E485	Error on input current sensor of inverter 1 (Short or Open)	Check Outdoor EEPROM PBA
62	E486	Over-voltage/low-voltage error of Fan1	FAN1 error

No.	Error Code	Meaning	Remarks
63	E487	Hall IC connection error of Fan1	FAN1 error
64	E489	V-limit error on Fan1 of compressor	FAN1 error
65	E491	Error due to DataFlash of Fan1	FAN1 error
66	E493	Output current sensor error of Fan1	FAN1 error
67	E496	DC voltage sensor error of Fan1	FAN1 error
68	E499	Heat sink temperature sensor error of Fan1	FAN1 error
69	E500	IPM over heat error on inverter 1	Check Outdoor Inverter PBA.
70	E508	Smart install is not installed	-
71	E554	Gas leak detected	Check the refrigerant
72	E556	Error due to mismatching capacity of indoor and outdoor unit	Check the indoor and Outdoor unit Capacity
73	E557	Option code miss matching among the indoor units (only for DPM)	Check the indoor option code
74	E590	Outdoor EEPROM checksum error between MAIN and INVERTER (AC***JXAFKH, AC***JXAFNH, AC***JXAPNH)	-
75	E660	Inverter Boot Code error	-

4-3 Troubleshooting by symptoms

4-3-1 Communication error after finishing tracking (E202)

1. Check items
 - 1) Is the communication cable short/open?
 - 2) Is there a response from the indoor unit PCB?
2. Check procedure

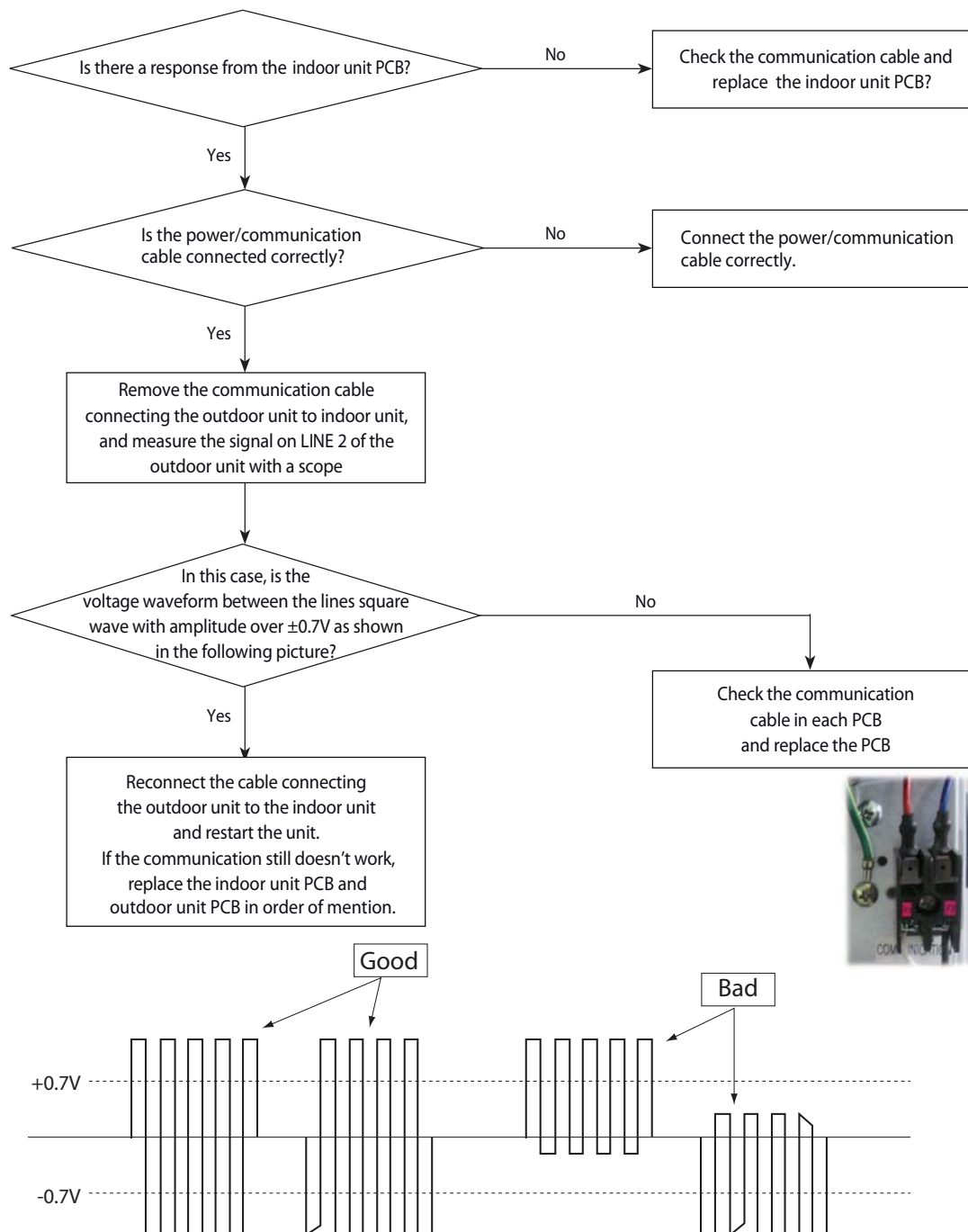

cf.) If there is no oscillo scope, it can be replaced multimeter instead of osillo scope.
 If measured voltage is floating value from 0.1V to 4.5V, then it means that the PCB is normal.

4-3-2 Outdoor's service valve(Clog)

Wire remote controller display	E422
Symptom	Clogging of outdoor's service valve
Failure	Valve clog

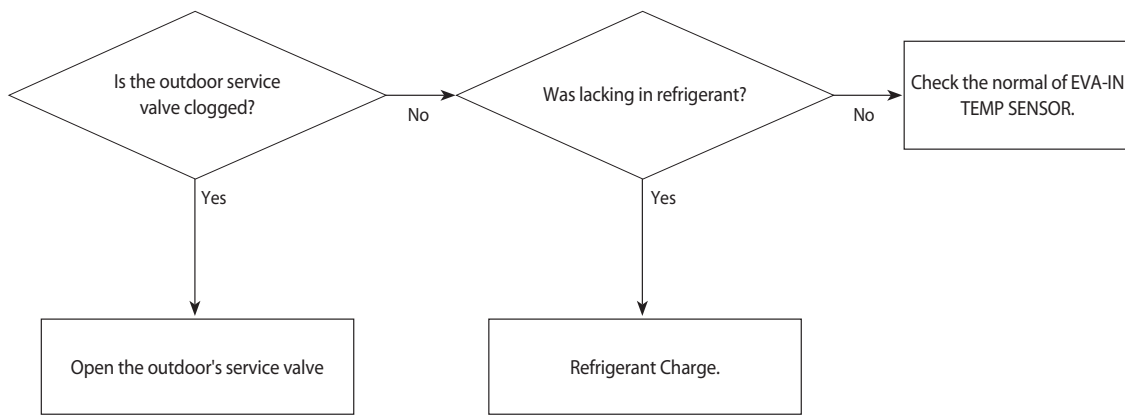

4-3-3 No Power(completely dead) - Initial diagnosis

Outdoor unit is not powered on – Initial diagnosis (1phase)

1. Check items
 - 1) Is the power supply voltage 220V?
 - 2) Is the AC power connected correctly?
 - 3) Are the LEDs in the main PCB and inverter PCB of the outdoor unit ON?
 - 4) Is the input power voltage of the indoor unit 220V?
 - 5) Is the wired remote controller connected correctly?
2. Check procedure

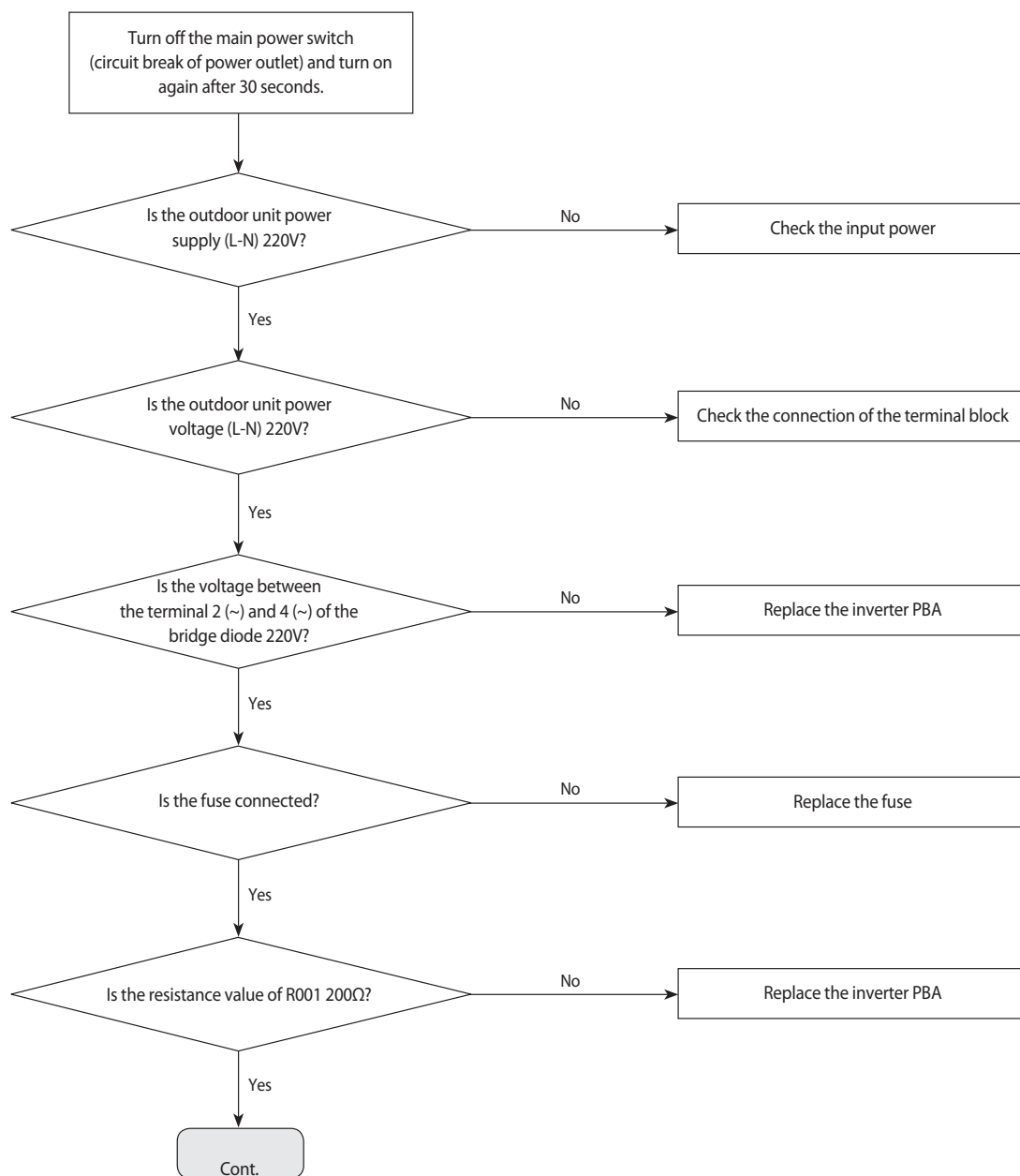

Outdoor unit is not powered on – Initial diagnosis (1phase) (cont.)

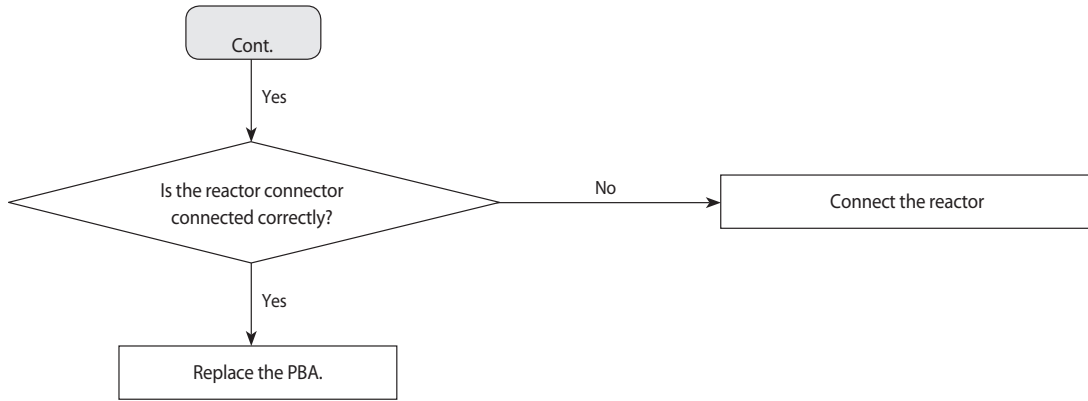

Outdoor unit is not powered on – Initial diagnosis (3phase)

1. Check items:
 - 1) Is the power supply voltage 380V?
 - 2) Is the AC power connected correctly?
 - 3) Are the LEDs in the main PCB and inverter PCB of the outdoor unit ON?
 - 4) Is the input power voltage of the indoor unit 220V?
 - 5) Is the wired remote controller connected correctly?

2. Troubleshooting procedure

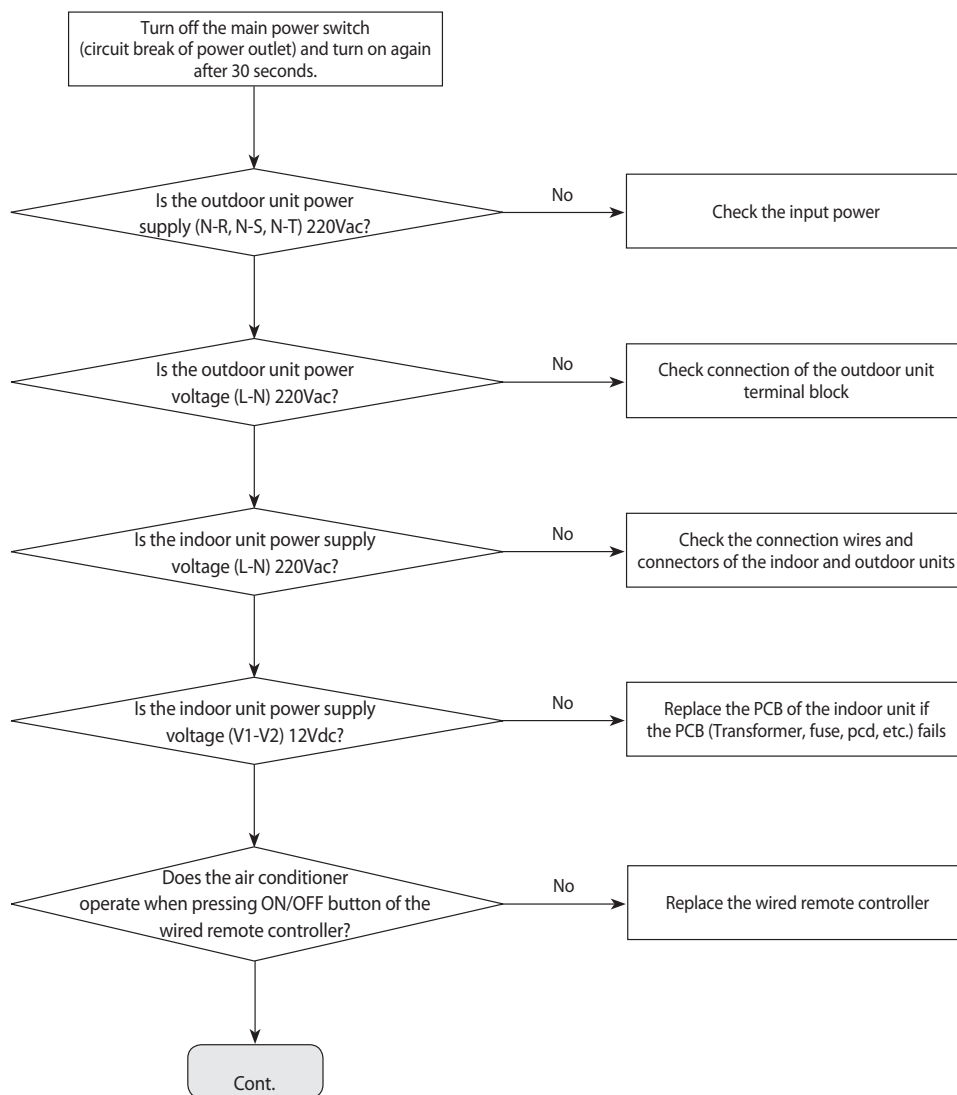

Outdoor unit is not powered on – Initial diagnosis (3phase) (cont.)

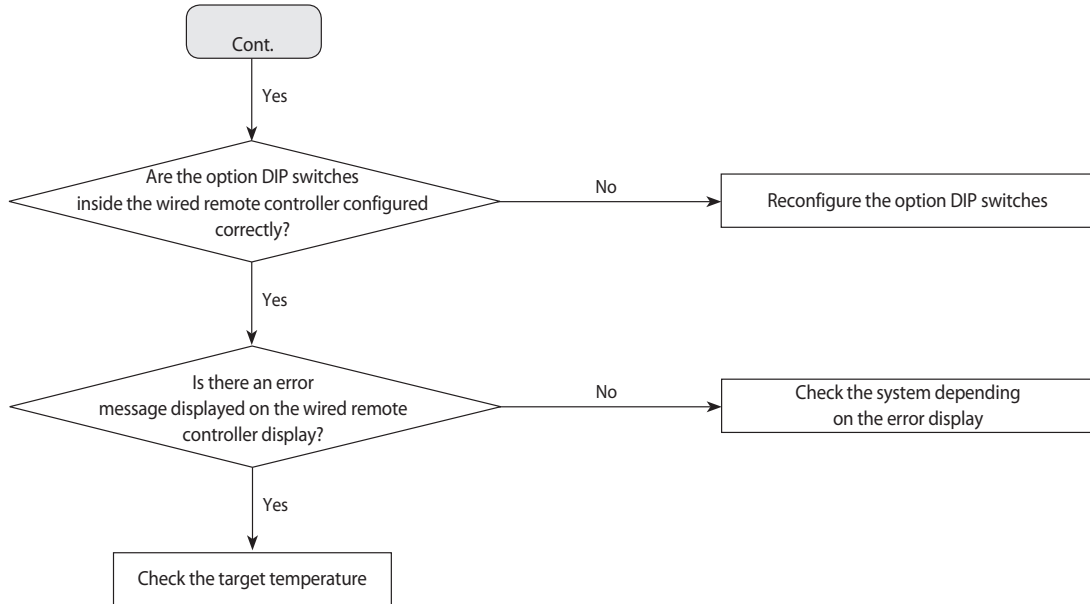

4-3-4 E102 : Communication error between indoor and outdoor unit
E201 : Unit quantity miss matching between Indoor and Outdoor
E202 : Abnormal state, no communication between Indoor and Outdoor Main PCB
E203 : 1min Time out of communication error(Main↔Inverter)

1. Checklist :

- 1) Is the communication cable between the indoor unit and outdoor unit connected correctly?
- 2) Isn't the power cable and communication cable wiring error?

2. Troubleshooting procedure

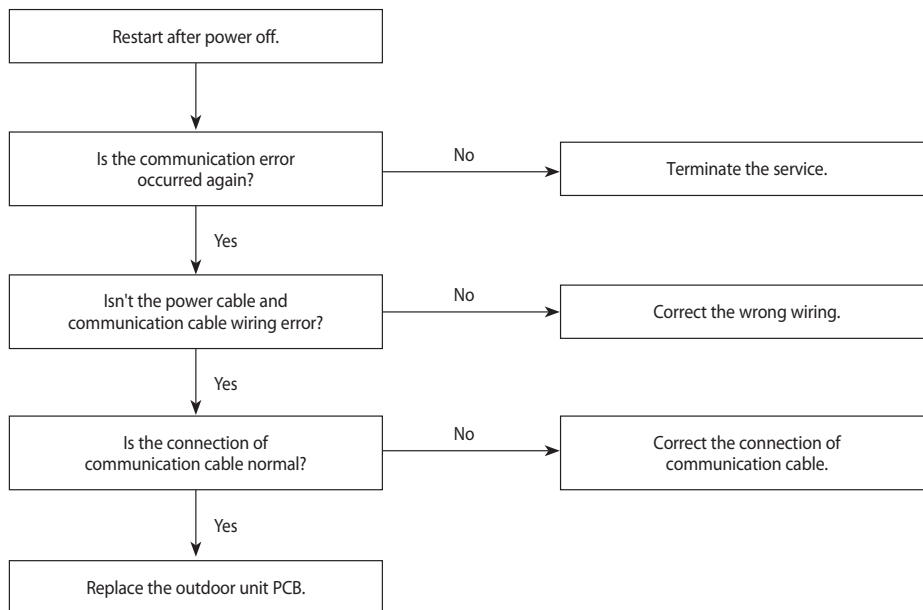

4-3-5 External Sensor Error (Error Code: E221, E231, E251, E320)

1. Test Item
 - 1) Check the connection of the temperature sensor connector.
 - 2) Check the resistance value of the temperature sensor.

Error Code	Description
E221	Error of the temperature sensor of the outdoor unit
E231	Error of the COND. sensor of the outdoor unit
E251	Error of the discharge sensor of the outdoor unit
E320	Error of the OLP sensor of the outdoor unit

2. Check procedure

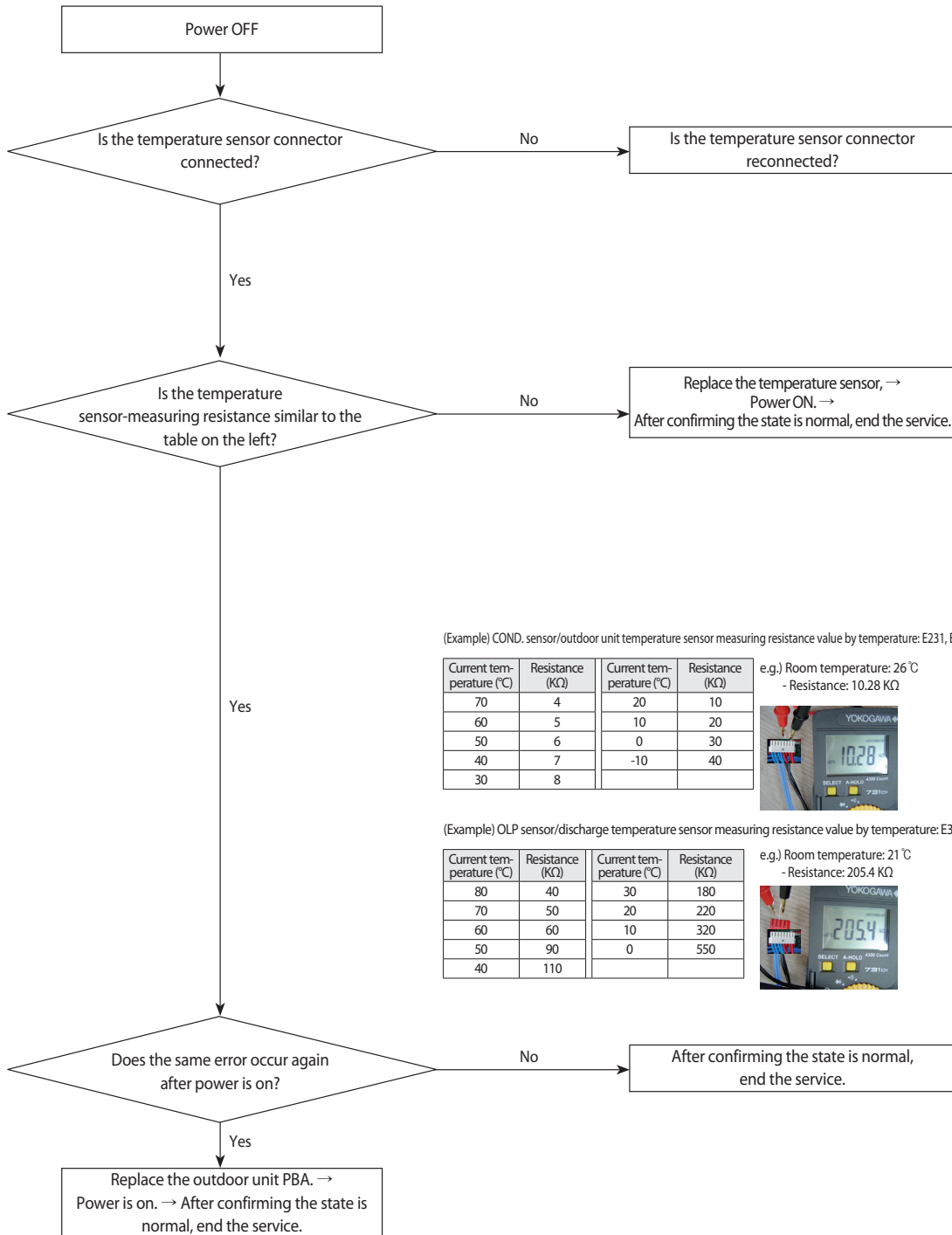

4-3-6 E403 : Freezing control causes comp. down

Outdoor unit display	E403
Criteria	•All the operating indoor machines do not reach -4°C for more than five minutes
Cause of problem	•Check if the indoor FAN/MOTOR operates normally. •Check if the indoor EEV operates normally. •Check the indoor heat Exchanger's IN/OUT sensor. •Check for clogging in the suction area of the indoor machine.

1. How to check

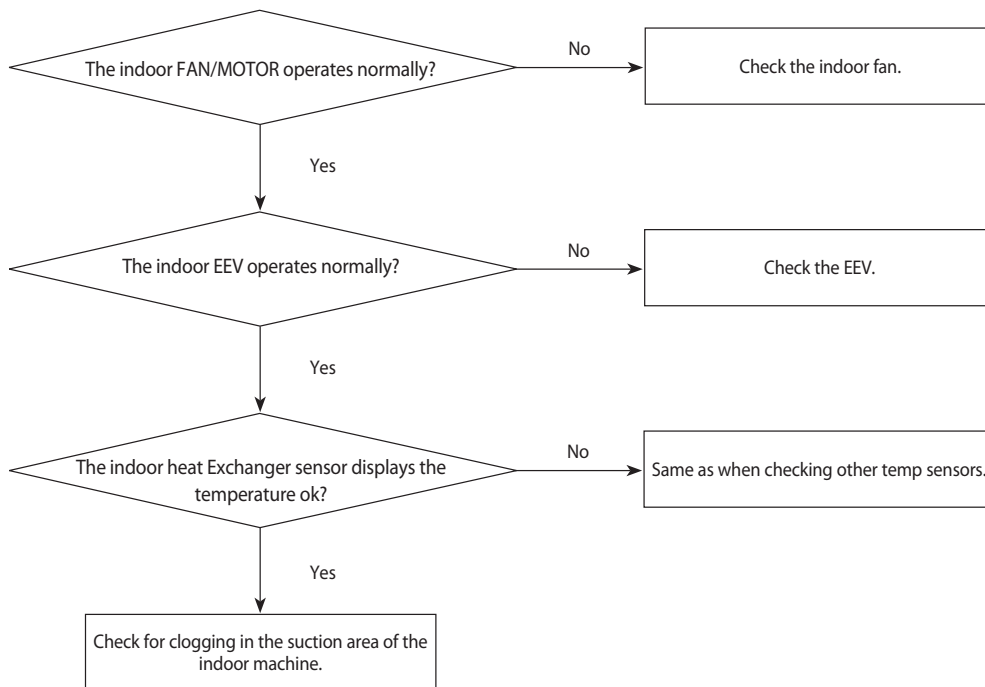

4-3-7 E416 : Dischage temperature sensor error

Outdoor unit display	E416
Criteria	•The compressor temperature above 110°C.
Cause of problem	<ul style="list-style-type: none"> •Insufficient coolant. •Clogging in the outdoor machine's solenoid valve. •Clogging in the sub valve. •Malfunctioning exhaust gas temp sensor. •Clogging in the pipeline and the filter. • Liquid EEV damaged.

1. How to check

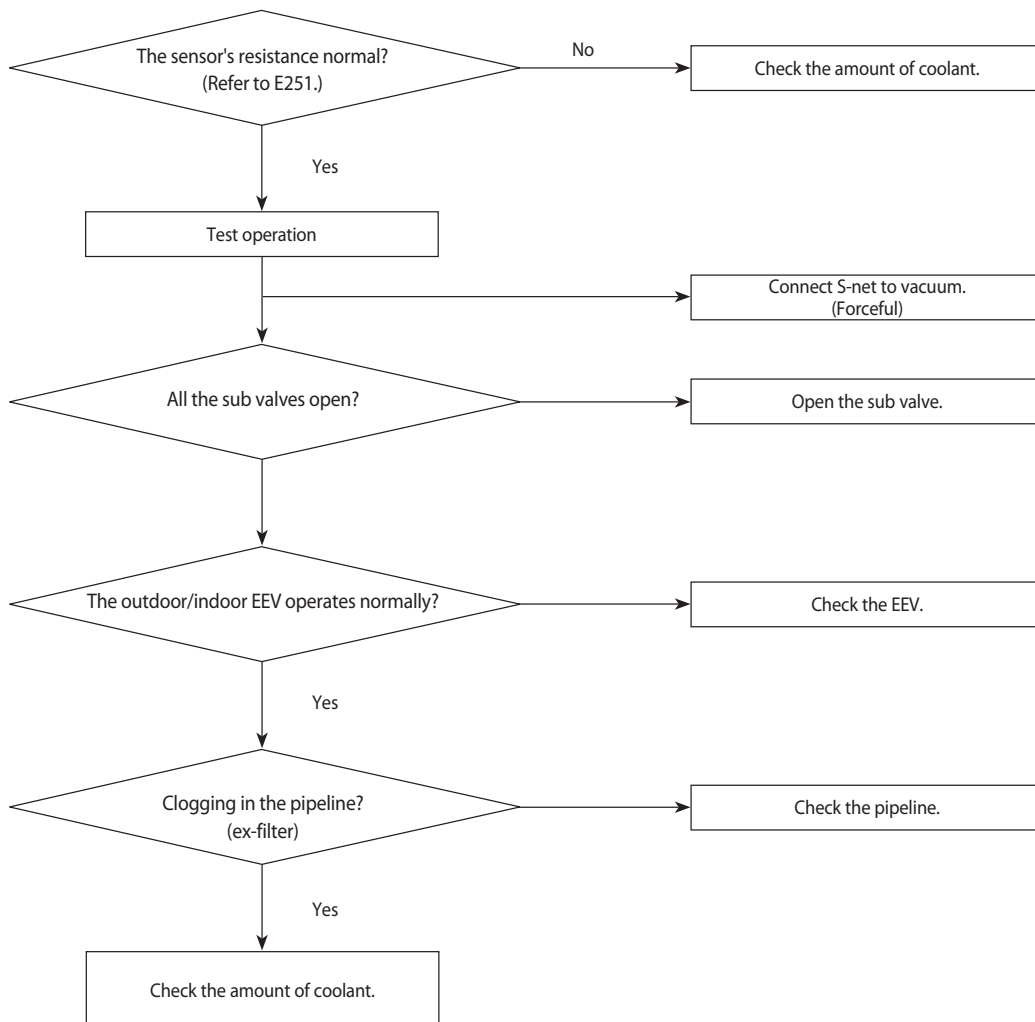

4-3-8 E440, E441 : Abnormal outside temperature halts operation of the compressor

Outdoor unit display	E440 (No heater operation with the outside temperature above 30°C.) E441 No AC operation with the outside temperature below -10°C.)
Criteria	•The compressor temperature above 110°C.
Cause of problem	E440: If the outside temperature is above 30°C, operation of the indoor heater with a remote control causes this error. E441: The indoor machine remote control ON signal. If the outside temperature is below -10°C before the AC runs, this error occurs.
Cause of problem	•OLP SENSOR temp above Trip_Dis.

1. How to check

The above malfunction codes do not indicate a malfunction of the product. All you have to do is change the temperature suitably for the limits shown in the manual. When the product malfunctions, if the actual situation does not match the above diagnosis, measure the temperature of incoming air with S-net to see if the measurement is the same as the actual outdoor temperature. If not, replace the temperature sensor.

4-3-9 Outdoor unit BLDC Fan1 or Fan2 error (E458 : Fan1 error, E475 : Fan2 error)

1. Checklist :

- 1) Isn't the fan locked?
- 2) Is the sensor placed correctly?
- 3) Does the both terminal of sensor satisfy the resistance value in accordance with temperature?
- 4) Is the resistance value of sensor connection pull_up correct?

2. Troubleshooting procedure

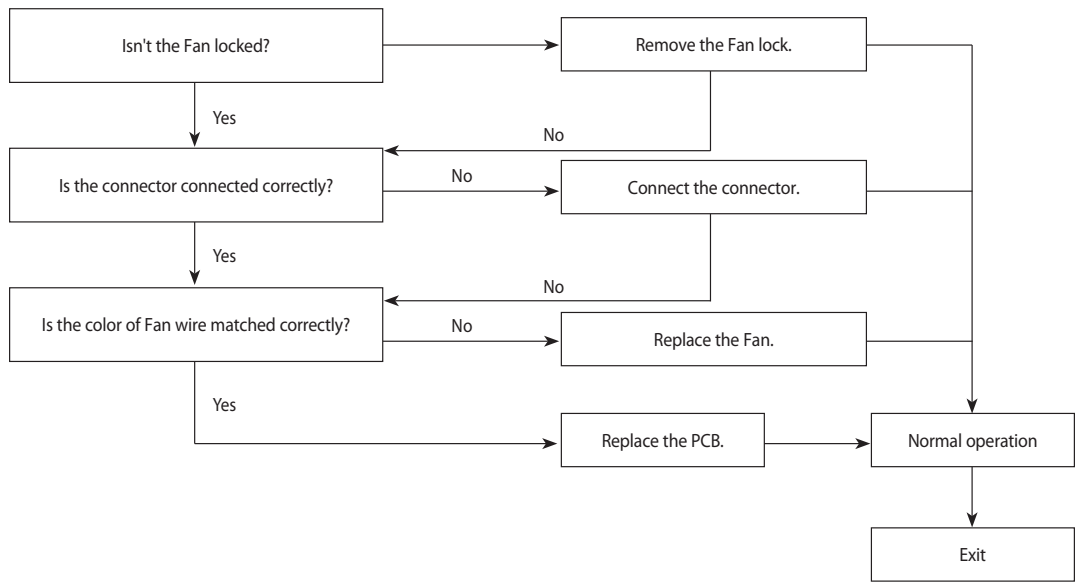

4-3-10 E461: Compressor start error E467: Compressor wire missing error

1. Checklist :
 - 1) Is the connection of cable for the compressor and power?
 - 2) Is the interphase resistance of compressor normal?
2. Troubleshooting procedure

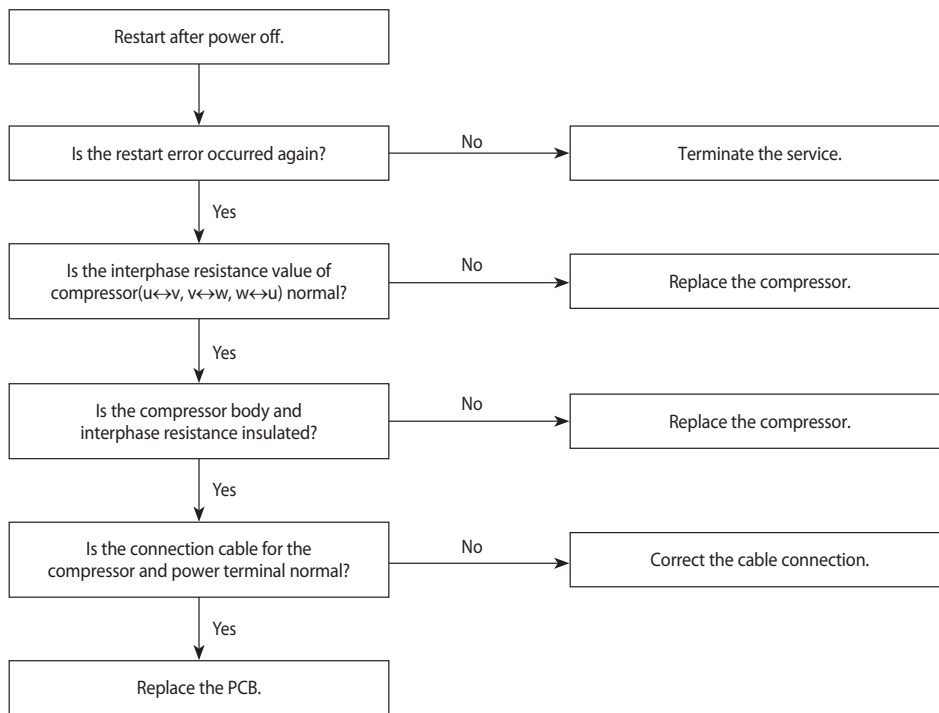

4-3-11 E462 : Current protection control causes comp. down E484 : PFC overload error

Outdoor unit display	E462,E484
Criteria	• The outdoor machine input current above I_Trip.
Cause of problem	•Check the compressor input voltage. (error for low voltage.) •Check the overcurrent option setting.

1. How to check

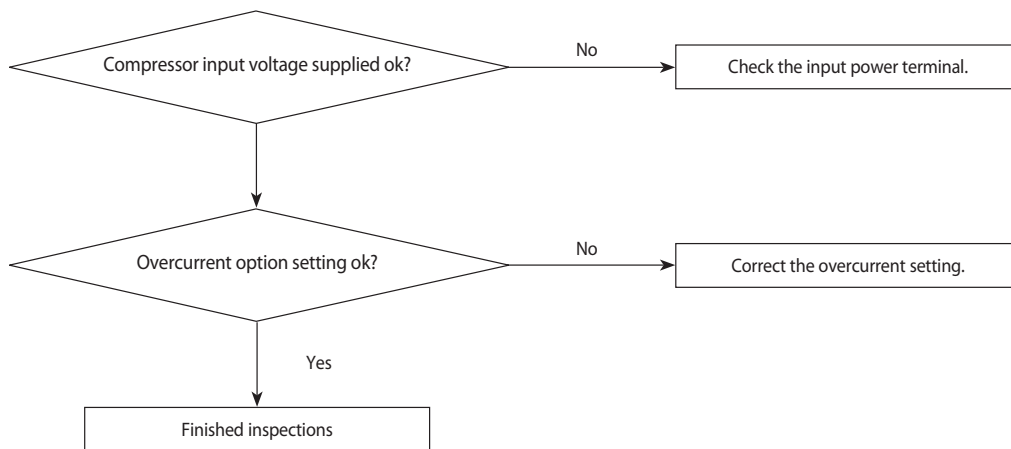

4-3-12 E463 : OLP protection control caused comp. down

Outdoor unit display	E463
Criteria	• OLP SENSOR temp above Trip_Dis.
Cause of problem	• See if the sub valve is open. • Check the amount of coolant. • Check the OLP sensor.

1. How to check

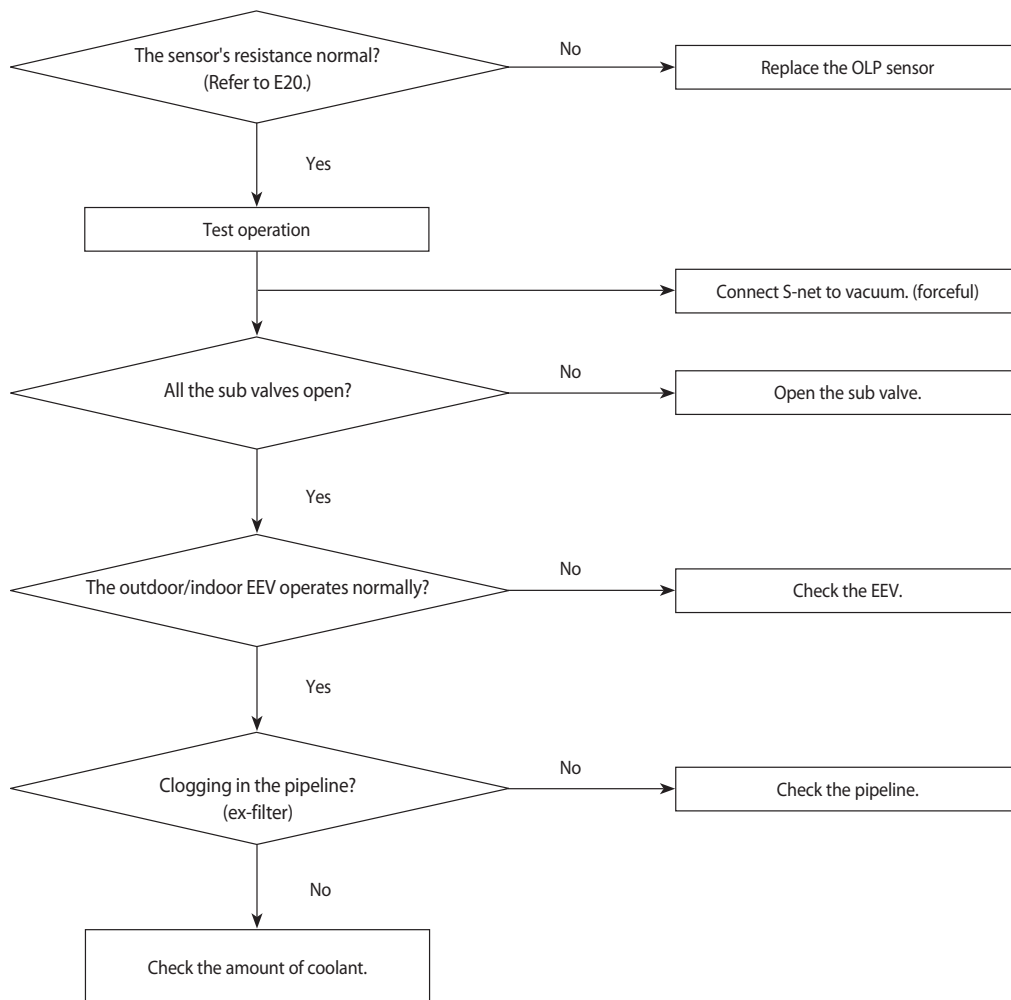

4-3-13 E464 : O.C. (Over Current) error

1. Checklist :

- 1) Is the refrigerant charged properly?
- 2) Does the compressor rotate normally?(Reverse rotation, Locking etc.)
- 3) Is connection of compressor wire normal?
- 4) Is compressor motor normal?(Insulation, Coil resistance etc.)
- 5) Does a temporary cycle overload condition happened?

2. Troubleshooting procedure

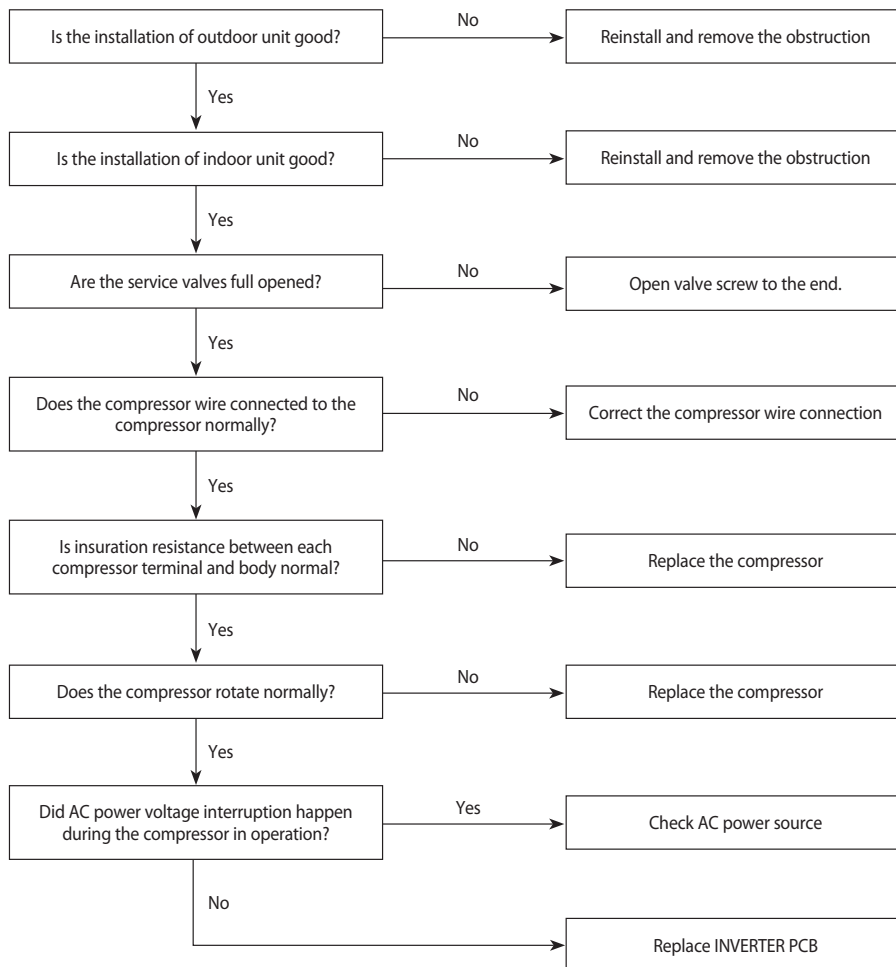

4-3-14 E466: DC Link Over voltage/ Low voltage error

1. Checklist :

- 1) Is the power voltage normal?(Lightning, Power interruption etc.)
- 2) Is AC Power cable connection normal?(Detaching the wire)

2. Troubleshooting procedure

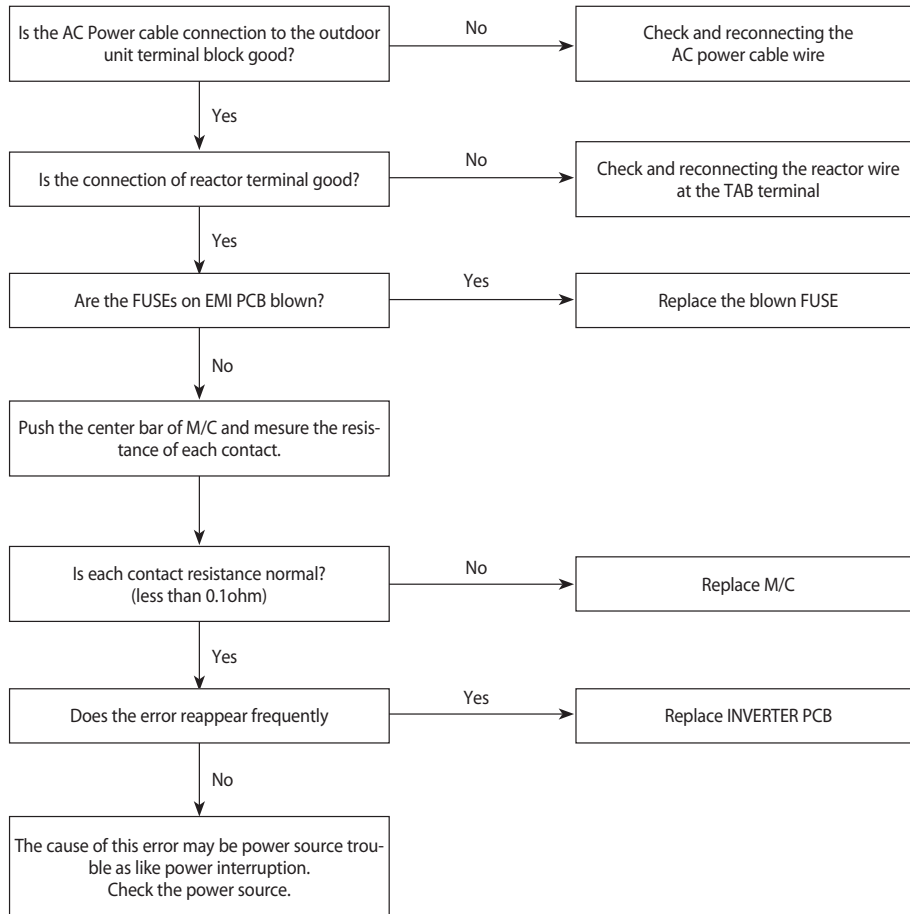

4-3-15 Pipe Blocking Error (Error Code: E422)

1. Test Item

- 1) Check the open state of the outdoor unit service valve.
- 2) Check the connection of the pipe.
- 3) Check the operation of the EEV.
- 4) Check the refrigerant leakage.
- 5) Check the connection of the indoor unit PBA EVA sensor.
- 6) Check the fault in the indoor unit EVA sensor.

2. Check procedure

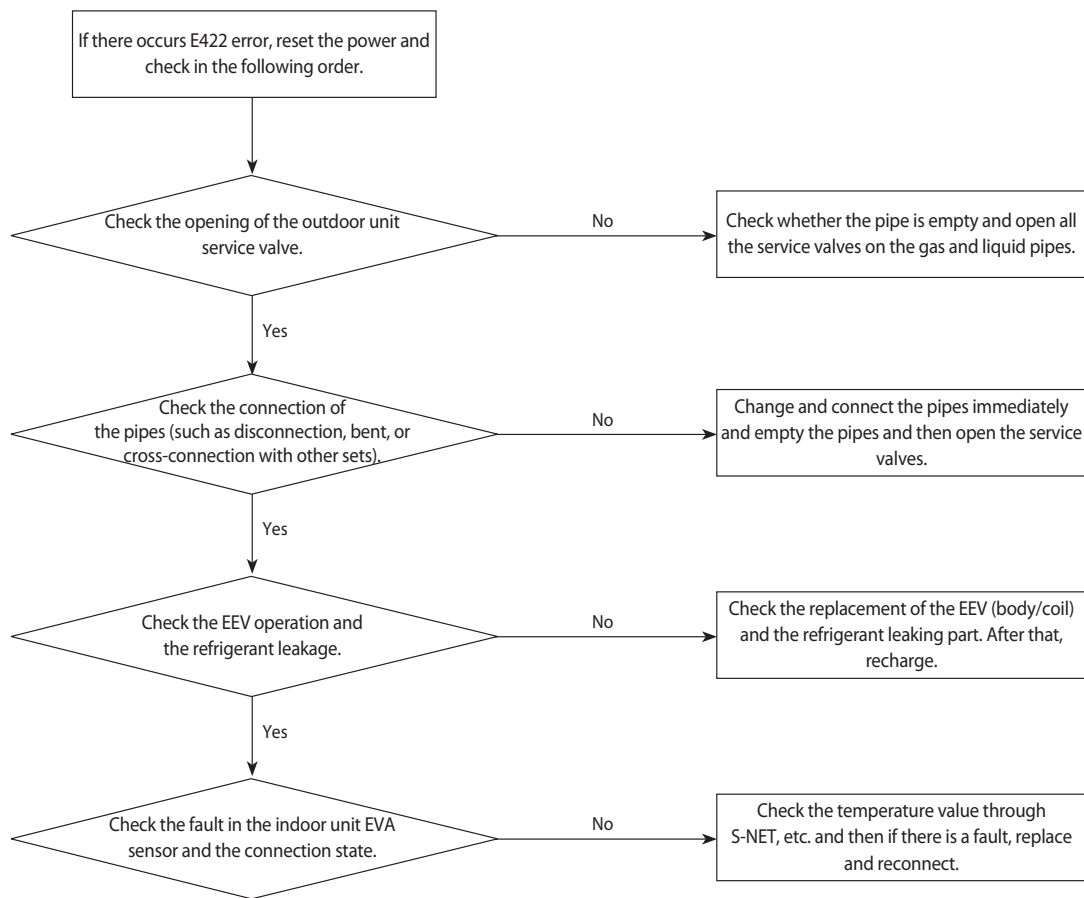

4-3-16 The others

1. E465 : Compressor over load error

- If a compressor works improperly, change the compressor and check if it works properly.
- If a compressor is normal, check the assembly between Heatsink-Inverter PBA. If it is fine, change Inverter PBA.

2. E468 : Current sensor error

- Check EEPROM data.
- Check PCB operates properly.

3. E471 : Outdoor EEPROM error

- Upload EEPROM on Outdoor unit Main PBA.

4. E474 : IPM(IGBT Module) or PFCM Temperature sensor Error

- E500 : IPM is over heated
- Check IPM is well assembled to heatsink
- Check whether inlet port is clogged.
- Change IPM if it is defective one

5. E554 : Gas leak error

- Check refrigerant charge
- Check Indoor EVA sensor
- Check Service valve is open.
- Check the pipes and wires correctly connected.

6. E556 : Capacity miss match between indoor and outdoor

- Check the model name of indoor and outdoor unit and set option code on indoor unit again.

7. Outdoor overload protection control (at the stop of the compressor): E404

- Check whether the fan and the motor operate normally.
- Check the operation of EEV.
- Check the temperature sensor of the indoor unit heat Exchanger.
- Check the indoor unit inlet blocking.

4-3-17 Setting an indoor unit installation option

■ Setting an indoor unit installation option(suitable for the condition of each installation location)

1. Check whether power is supplied or not.
 - When the indoor unit is not plugged in, there should be additional power supply in the indoor unit.
2. The panel(display) should be connected to an indoor unit to receive option.
3. Set the installation option according to the installation condition of an air conditioner.
 - The default setting of an indoor unit installation option is 02000-100000-200000-300000.
4. Set the indoor unit option by wireless remote controller.

SEG1	SEG2	SEG3	SEG4	SEG5	SEG6
0	2	RESERVED	RESERVED	RESERVED	RESERVED
SEG7	SEG8	SEG9	SEG10	SEG11	SEG12
1	RESERVED	RESERVED	RESERVED	RESERVED	RESERVED
SEG13	SEG14	SEG15	SEG16	SEG17	SEG18
2	External control	External control output	RESERVED	RESERVED	RESERVED
SEG19	SEG20	SEG21			
3	RESERVED	Heating setting compensation			

- ▶ Heating setting compensation (SEG21) is applied to Heat pump model only.

5. PCB Diagram

5-1 Indoor unit

5-1-1 Main PCB

▶ This Document can not be used without Samsung's authorization.

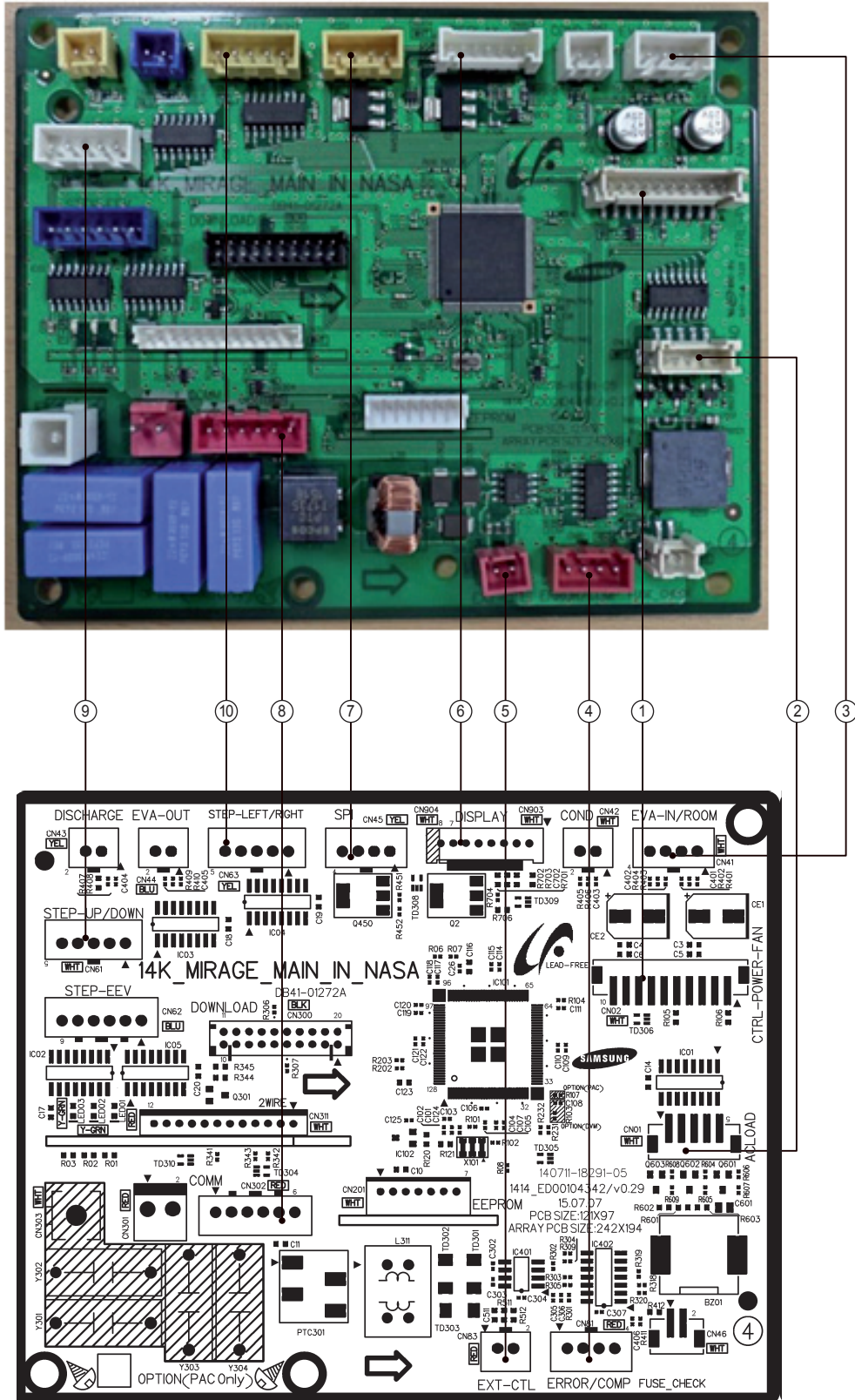

<p>① CN02-CTRL-POWER-FAN</p> <p>#1 : DETECT_OV_UV #2 : INRUSH_RY #3 : PWR_RY #4 : Zerocrossing #5 : RPM_Feedback #6 : FAN_PWM #7 : BLDC_PS #8 : DC 5V #9 : GND #10 : DC 12V</p>	<p>② CN01-AC LOAD</p> <p>#1 :- #2 :- #3 : FAN LOW_COMP #4 : FAN HIGH_FAN #5 : FAN TURBO_4WA</p>	<p>③ CN41-EVA IN/ROOM</p> <p>#1 : ROOM-TH #2 : GND #3 : EVA IN-TH #4 : GND</p>	<p>④ CN81-ERROR/COMP</p> <p>#1 : DC 12V #2 : ERROR_Check #3 : DC 12V #4 : Comp_Chec</p>
<p>⑤ CN83-EXT_CTRL</p> <p>#1 : GND #2 : External control</p>	<p>⑥ CN903-DISPLAY</p> <p>#1 : DC 12V #2 : GND #3 : PANEL_TXD #4 : PANEL_RXD #5 : REMOCON_RXD #6 : DC 5V #7 : KEY_INT</p>	<p>⑦ CN45-SPI</p> <p>#1 : GND #2 : GND #3 : SPI_Control #4 :-</p>	<p>⑧ CN302-COMM</p> <p>#1 : F1 #2 : F2 #3 : DC 12V #4 : GND #5 : F3 #6 : F4</p>
<p>⑨ CN61-STEP UP/DOWN</p> <p>#1 : DC 12V #2 : UB_12B' #3 : UB_12A' #4 : UB_12B #5 : UB_12A</p>	<p>⑩ CN63-STEP LEFT/RIGHT</p> <p>#1 : DC 12V #2 : UB_12B' #3 : UB_12A' #4 : UB_12B #5 : UB_12A</p>		

5-1-2 Power PCB

► This Document can not be used without Samsung's authorization.

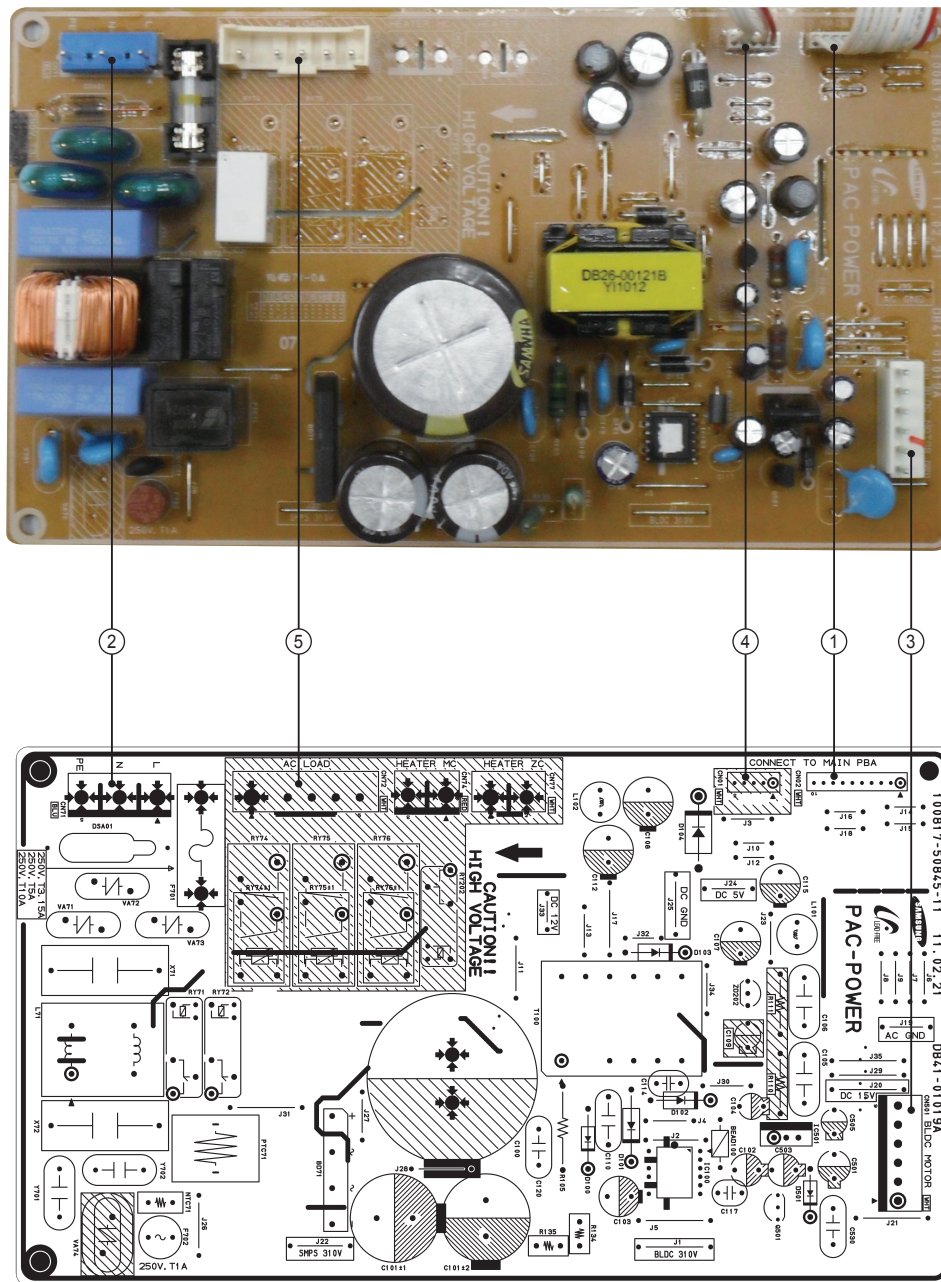

① CN02-MAIN PBA	② CN71-POWER	③ CN501-BLDC MOTOR	④ CN02-MAIN PBA	⑤ CN72-AC LOAD
#1 : DC12V #2 : GND #3 : DC5V #4 : BLDC_PS #5 : FAN_PWM #6 : RPM_FEEDBACK #7 : ZEROCROSS #8 : PWR_RY_12 #9 : INRUSH_RY_12 #10 : DETECT_OV/LV	#1 : L #2 : NC #3 : N #4 : NC #5 : EARTH	#1 : DC310V #2 : NC #3 : AGND #4 : DC15V #5 : Vsp #6 : RPM_FEEDBACK	#1 : FAN_TURBO_4WAYWY_12 #2 : FAN_HIGH_FAN_12 #3 : FAN_LOW_COMP_12 #4 : HEATER_CTRL_12A #5 : HEATER_ZC	#1 : N #2 : NC #3 : COMPRESSOR #4 : OUTDOOR FAN MOTOR #5 : OUTDOOR 4WAY/VV

5-1-3 Panel PCB

► This Document can not be used without Samsung's authorization.

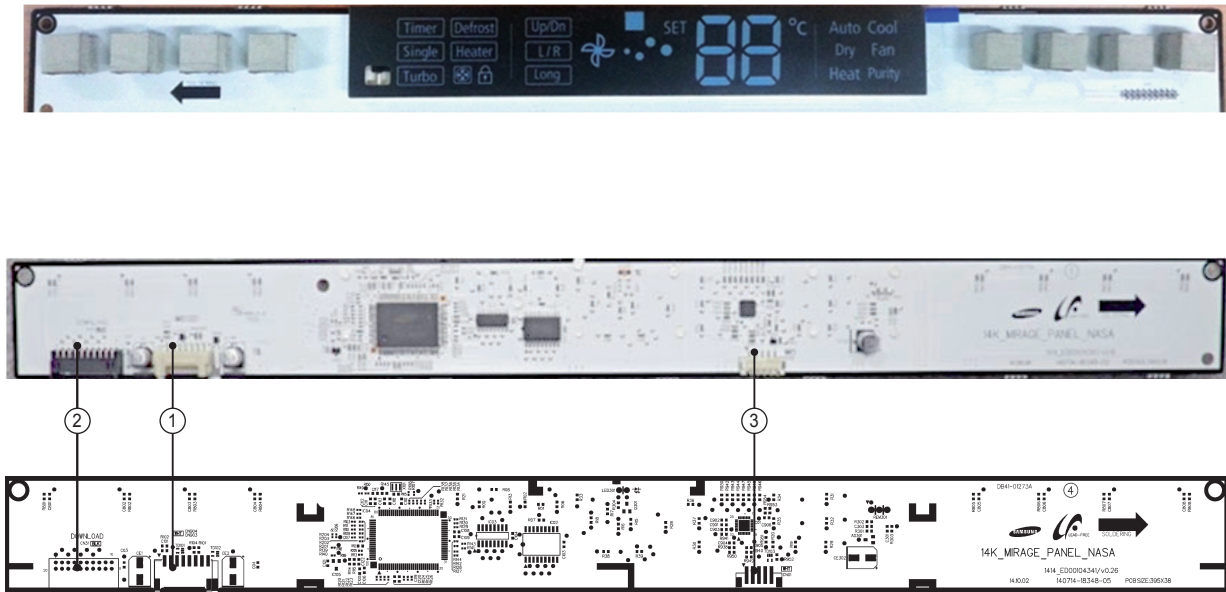

<p>① CN903-DISPLAY</p> <p>#1 : DC 12V #2 : GND #3 : PANEL_TXD #4 : PANEL_RXD #5 : REMOCON_RXD #6 : DC 5V #7 : KEY_INT</p>	<p>② CN31-DOWNLOAD(MICOM)</p> <p>#1~#20 : Download</p>	<p>③ CN01-DOWNLOAD(Touch-IC)</p> <p>#1 : DC 5V #2 : GND #3 : - #4 : I2C #5 : I2C</p>
--	---	---

5-2 OUTDOOR

5-2-1 MAIN PCB Diagram

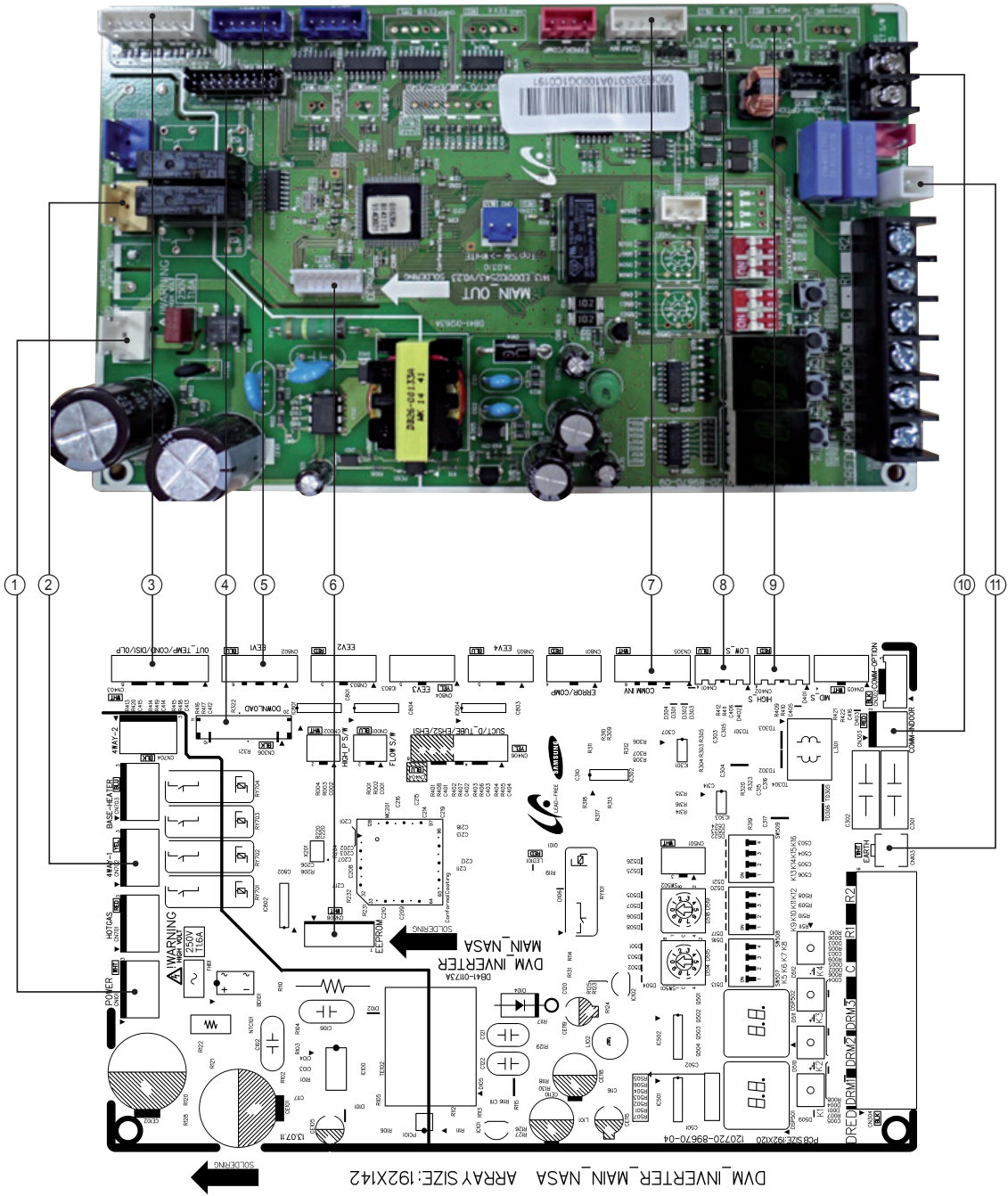

<p>CN101 - POWER</p> <p>#1 : L #2 : N.C #3 : N</p>	<p>CN702 - 4WAY</p> <p>#1 : N #2 : N.C #3 : 4WAY V/V SIGNAL</p>	<p>CN403 - SENSOR</p> <p>#1 : OUT TEMP #2 : GND #3 : COND TEMP #4 : GND #5 : DISCHARGE TEMP #6 : GND #7 : OLP TEMP #8 : GND</p>	<p>CN306 - DOWNLOAD</p> <p>#1 ~ #20 : DOWNLOAD</p>
<p>CN802 - EEV</p> <p>#1 ~ #4 : EEV SIGNAL #5,#6 : DC 12V</p>	<p>CN806 - EEPROM</p> <p>#1 ~ #7 : EEPROM</p>	<p>CN305 - COMM INV</p> <p>#1 : COMM SIGNAL #2 : COMM SIGNAL #3 : GND #4 : DC 5V #5 : DC 12V #6 : COMM SIGNAL</p>	<p>CN401 - LOW PRESSURE</p> <p>#1 : N.C #2 : SENSOR SIGNAL #3 : GND #4 : DC 5V</p>
<p>CN402 - HIGH PREWSSURE</p> <p>#1 : SENSOR SIGNAL #2 : N.C #3 : GND #4 : DC 5V</p>	<p>CN303 - COMM INDOOR</p> <p>#1 ~ # 2 : COMM SIGNAL</p>	<p>CN103 - EARTH</p> <p>#1 : EARTH</p>	

5-2-2 INVERTER PCB

■ AC048KXQPCC

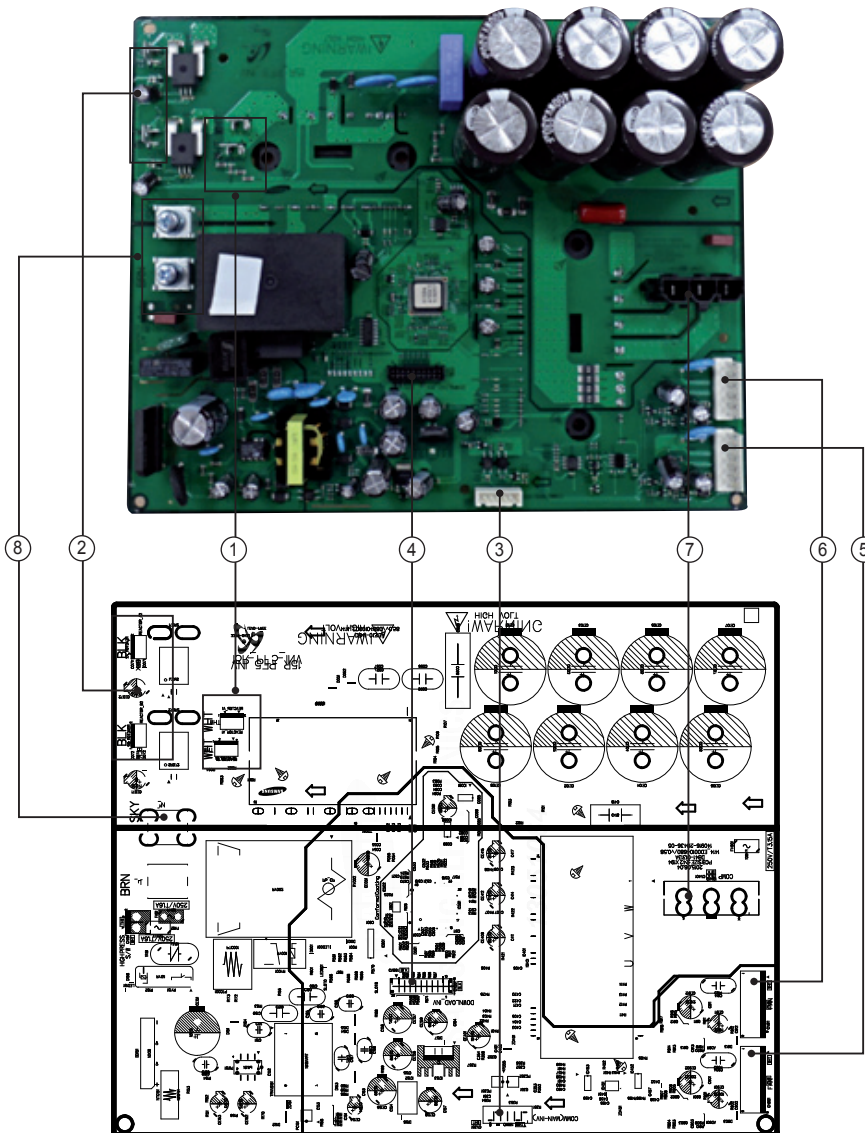

<p>① Reactor - A1/B1 # Reactor - A1 : WHT # Reactor - B1 : WHT</p>	<p>② Reactor - A2/B2 # Reactor - A2 : BLK # Reactor - B2 : BLK</p>	<p>③ CN351 - Communication #1 : RXD #2 : TXD #3 : GND #4 : DV5V #5 : DV12V #6 : INV, SMPS Signal</p>	<p>④ CN551 - Downloader #1 : RXD_INV #2 : TXD_INV #3 : BOOT_INV #4 : TDO_INV #5 : TCK_INV #6 : TDI_INV #7 : TMS_INV #8 : nTRST #9 : GND #10~#11 : 5V #14 #18 #19 : ENC #17 : GND #20 : SUB</p>
<p>⑤ CN901-FAN1 #1 : DC310V #2 : N.C #3 : GND #4 : DV15V #5 : FAN RPM #6 : FAN RPM Feedback</p>	<p>⑥ CN911-FAN2 #1 : DC310V #2 : N.C #3 : GND #4 : DV15V #5 : FAN RPM #6 : FAN RPM Feedback</p>	<p>⑦ CN401-COMP. # 1 : COMP. U-phase(RED) # 2 : COMP. V-phase(BLU) # 3 : COMP. W-phase(YEL)</p>	<p>⑧ L, N - 220V Power # 1 : L-phase(BRN) # 2 : N-phase(SKY)</p>

■ AC036KXQPCC / AC100KXADEH / AC036KXADEC

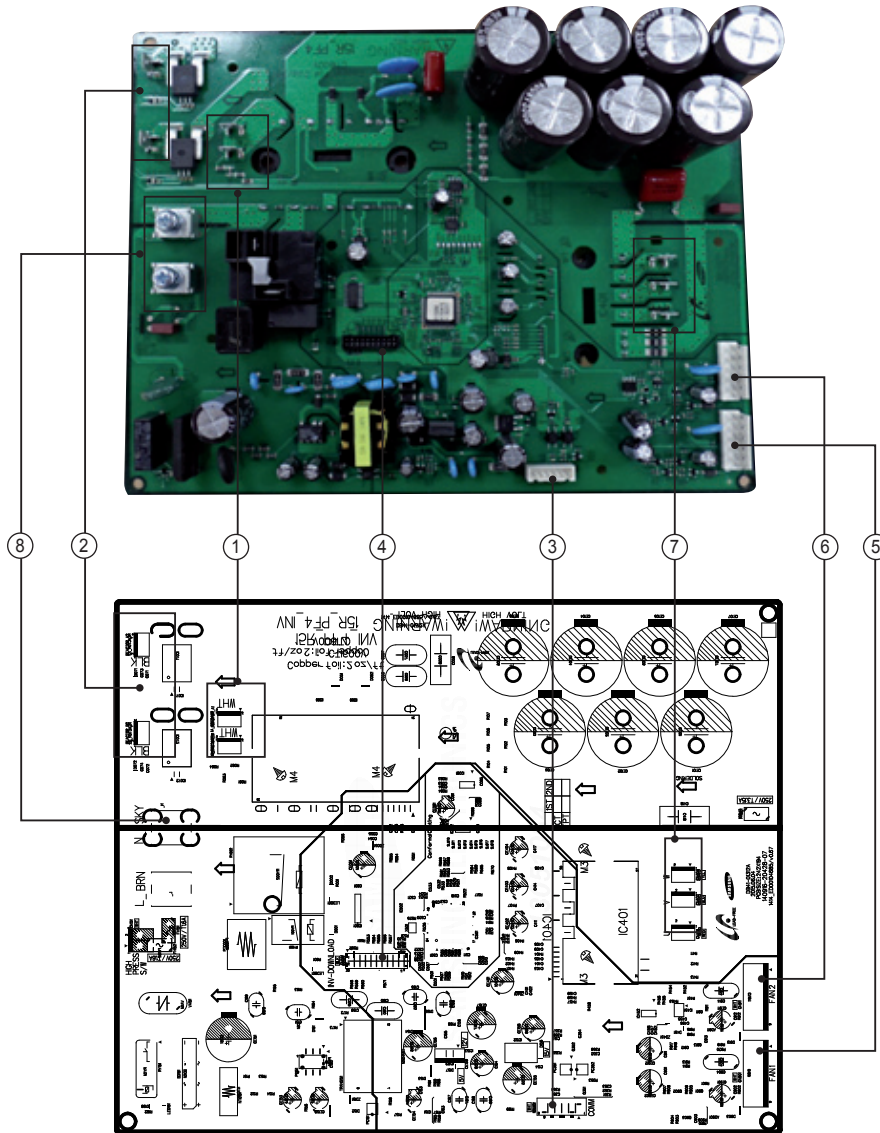

<p>① Reactor - A1/B1 #Reactor -A1 : WHT #Reactor -B1 : WHT</p>	<p>② Reactor - A2/B2 #Reactor -A2 : BLK #Reactor -B2 : BLK</p>	<p>③ CN351 - Communication #1 : RXD #2 : TXD #3 : GND #4 : DV5V #5 : DV12V #6 : INV, SMPS Signal</p>	<p>④ CN551 - Downloader #1 : RXD_INV #2 : TXD_INV #3 : BOOT_INV #4 : TDO_INV #5 : TCK_INV #6 : TDI_INV #7 : TMS_INV #8 : nTRST #9 : GND #10~#11: 5V #14 #18 #19 : ENC #17 : GND #20 : SUB</p>
<p>⑤ CN901-FAN1 #1 : DC310V #2 : N.C #3 : GND #4 : DV15V #5 : FAN RPM #6 : FAN RPM Feedback</p>	<p>⑥ CN911-FAN2 #1 : DC310V #2 : N.C #3 : GND #4 : DV15V #5 : FAN RPM #6 : FAN RPM Feedback</p>	<p>⑦ CN401,402,403-COMP. CN401 : COMP. U-phase(RED) CN402 : COMP. V-phase(BLU) CN403 : COMP. W-phase(YEL)</p>	<p>⑧ L, N - 220V Power #1 : L-phase(BRN) #2 : N-phase(SKY)</p>

■ AC140KXADGH / AC048KXADGC

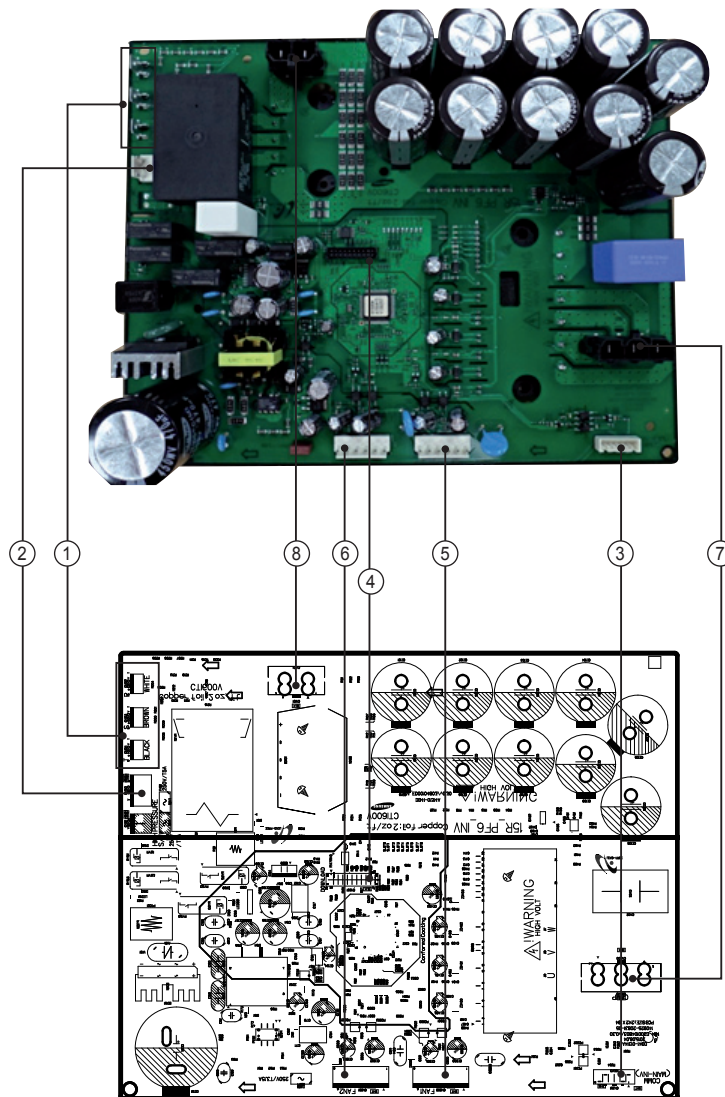

<p>① RST - AC Power 3 Phase #R : AC 380~400V : WHT #S : AC 380~400V : BRN #T : AC 380~400V : BLK</p>	<p>② CN152 - AC Power #1-#3 : AC 220~240V</p>	<p>③ CN351 - Communication #1 : RXD, #2 : TXD #3 : GND, #4 : DC 5V #5 : DC 12V, #6 : INV. SMPS Signal</p>	<p>④ CN551 - Downloader #1 : RXD_INV #2 : TXD_INV #3 : BOOT_INV #4 : TDO_INV #5 : TCK_INV #6 : TDL_INV #7 : TMS_INV #8 : nTRST #9 : GND #10~#11 : 5V #14 #18 #19 : ENC #17 : GND #20 : SUB</p>
<p>⑤ CN901-FAN1 #1 : DC310V #2 : N.C #3 : GND #4 : DV15V #5 : FAN RPM #6 : FAN RPM Feedback</p>	<p>⑥ CN911-FAN2 #1 : DC310V #2 : N.C #3 : GND #4 : DV15V #5 : FAN RPM #6 : FAN RPM Feedback</p>	<p>⑦ CN400-COMP. #1 : COMP. U-phase(RED) #2 : COMP. V-phase(BLU) #3 : COMP. W-phase(YEL)</p>	<p>⑧ CN101-Reactor #1~#2 : Reactor</p>

5-2-3 EMI PCB

■ AC048KXQPCC / AC036KXQPCC / AC100KXADEH / AC036KXADEC

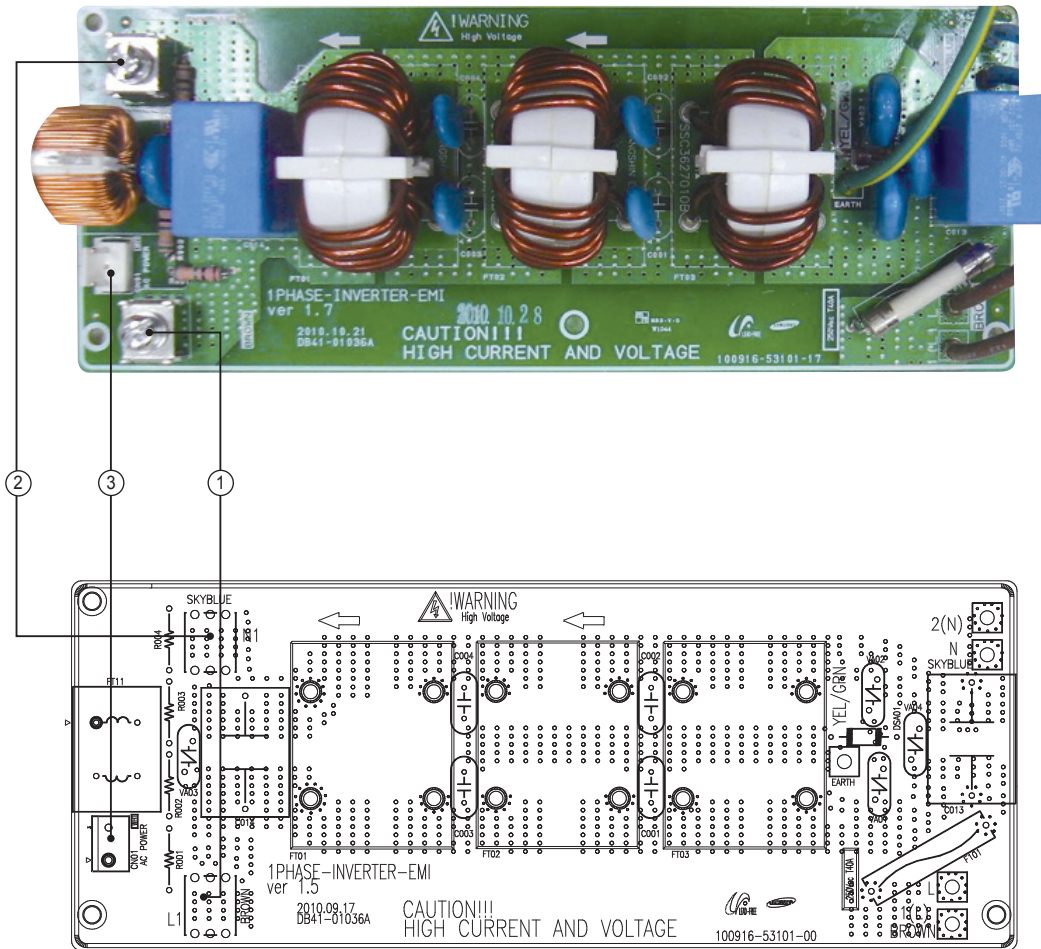

<p>① L1-AC POWER L phase L1 : BRN</p>	<p>② N1-AC POWER N phase N1 : SKY-BLU</p>	<p>③ CN01-AC POWER #1-#3 : AC 220~240V</p>
--	--	---

■ AC140KXADGH / AC048KXADGC

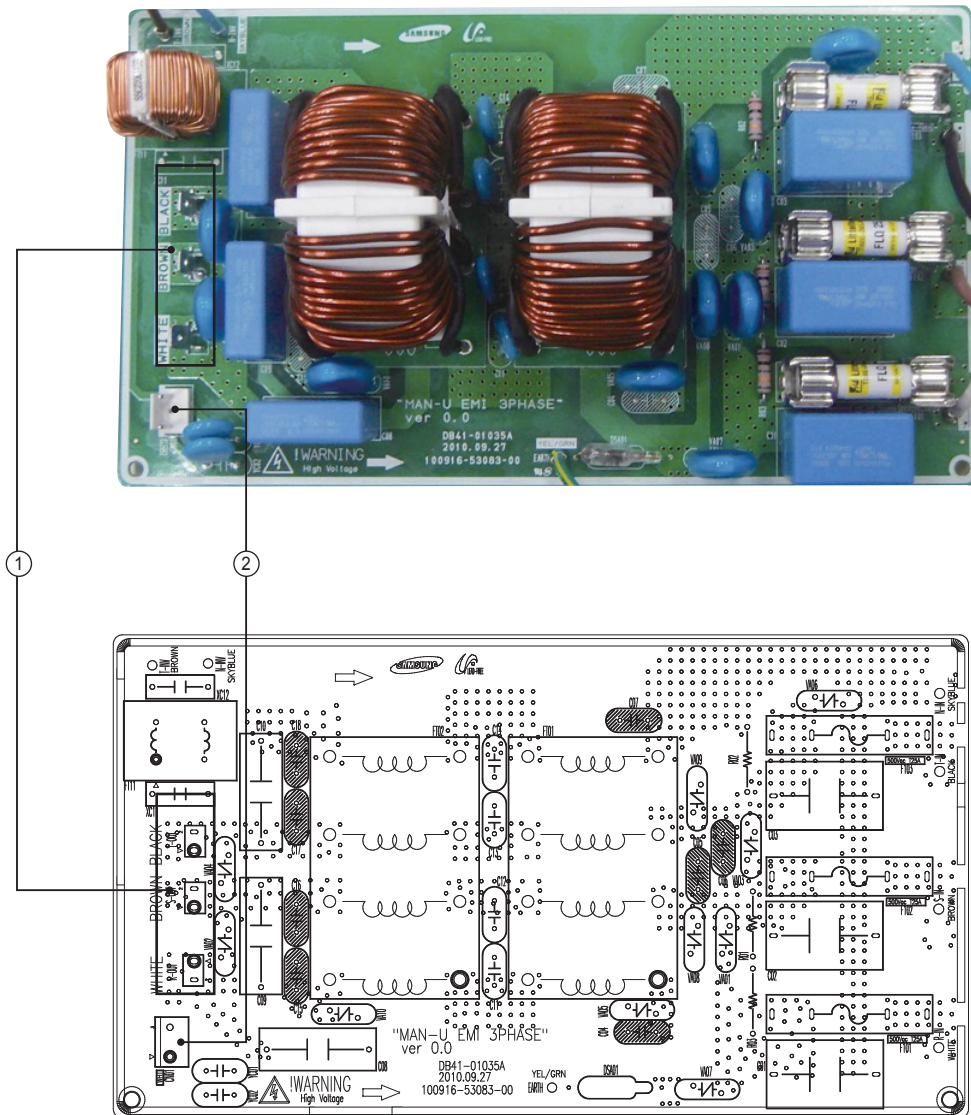

<p>① RST-AC POWER 3phase #R : AC 380~400V : WHT #S : AC 380~400V : BRN #T : AC 380~400V : BLK</p>	<p>② CN100-AC POWER #1-#3 : AC 220~240V</p>
---	---

6. Wiring Diagram

6-1 Indoor Unit

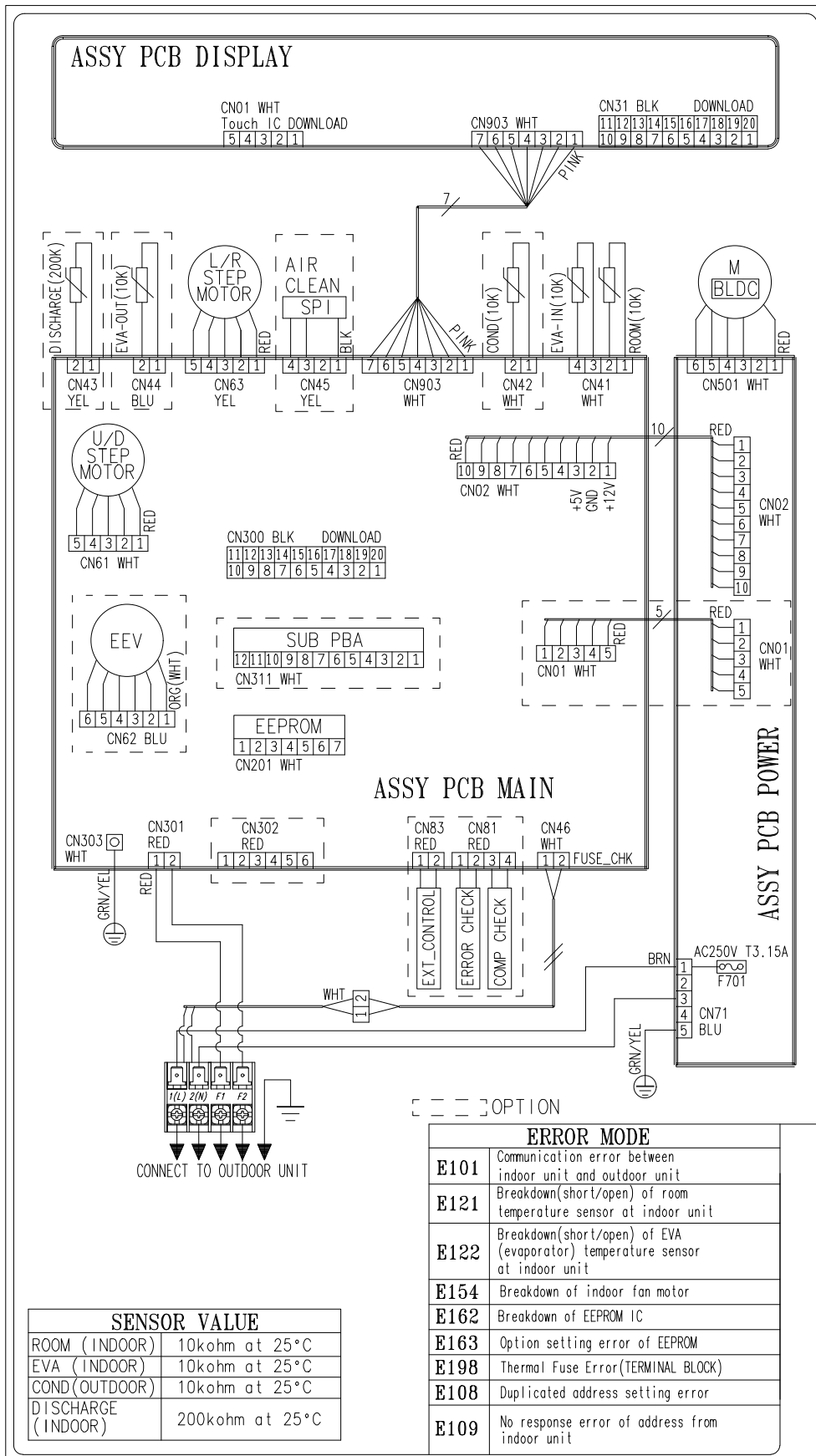

■ AC140KXADGH / AC048KXADGC

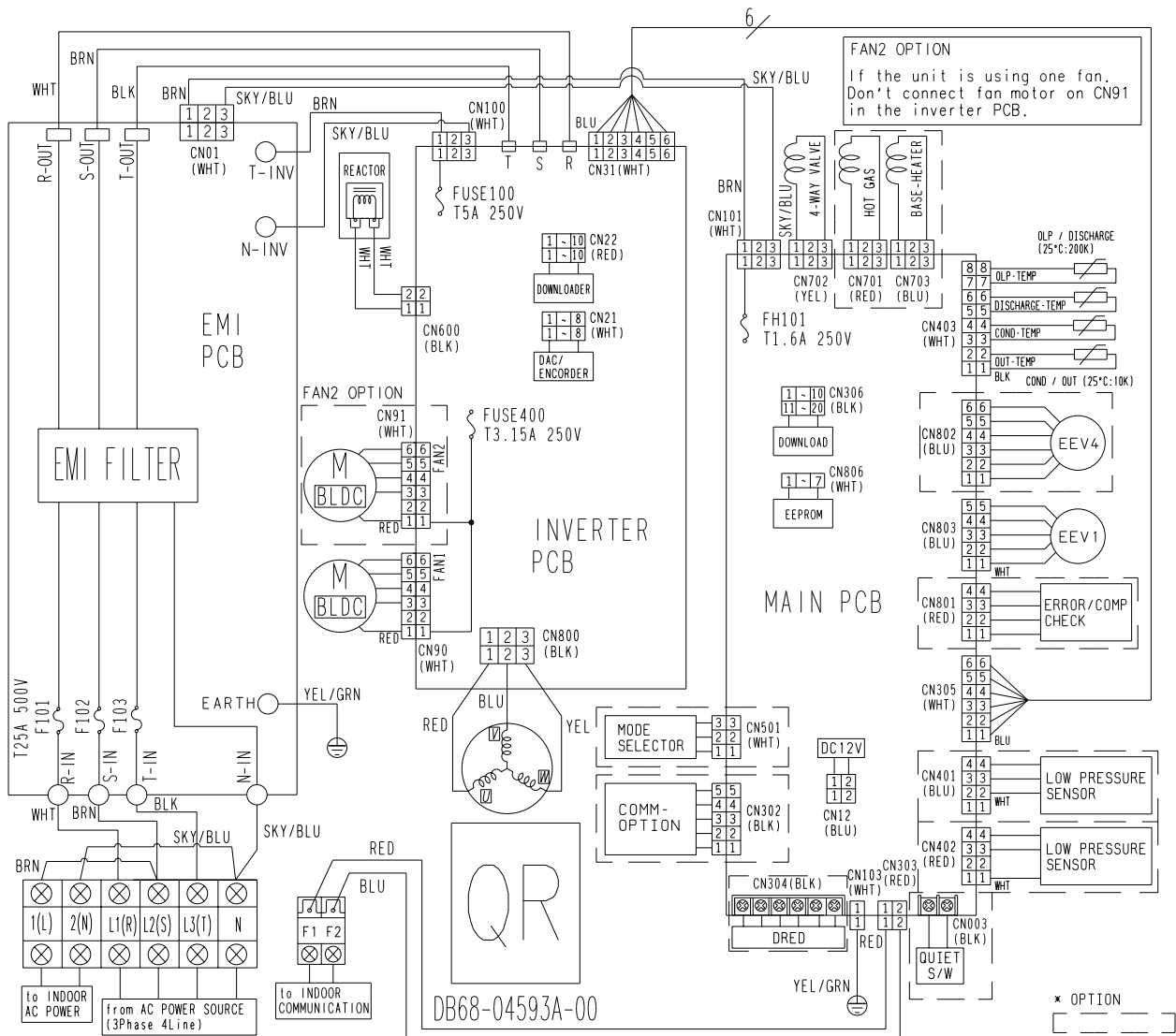

This Document can not be used without Samsung's authorization.

7. Reference Sheet

7-1 Index for Model Name

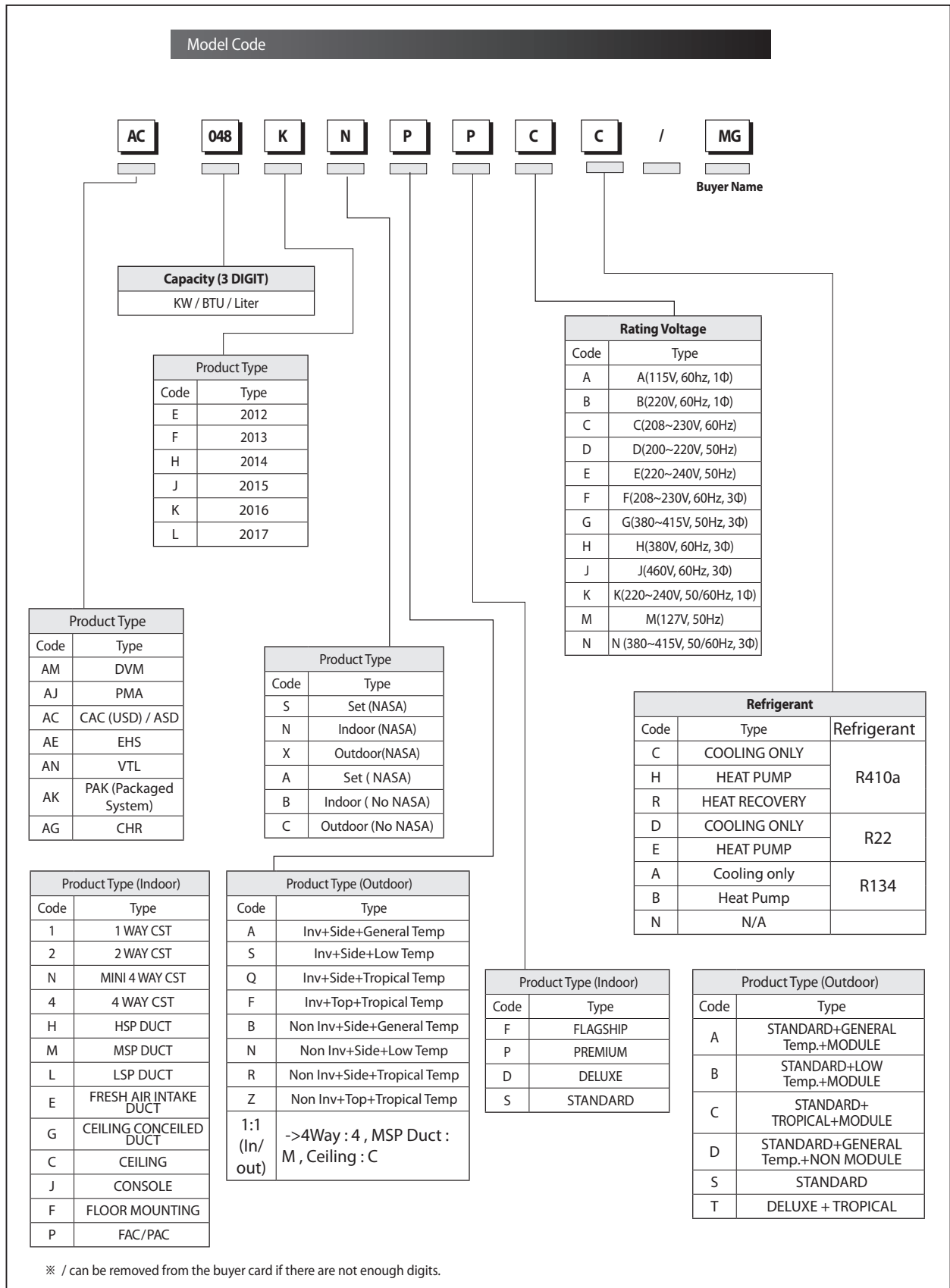

7-2 Refrigerating Cycle Diagram

■ AC048KXQPCC

Indoor unit	Heat Exchanger	PFE 12mm, 2X63X785, 6-1PASS, FP1.5, Louver
	Fan Motor	BLDC, Sirocco, [C/H] 510/450/390 [rpm]
Outdoor unit	Heat Exchanger	FMC 16mm, 1R*69S*910, 2EA, FP1.4, Corrugate
	Fan Motor	BLDC, Propeller, RPM MAX : 800 [rpm]

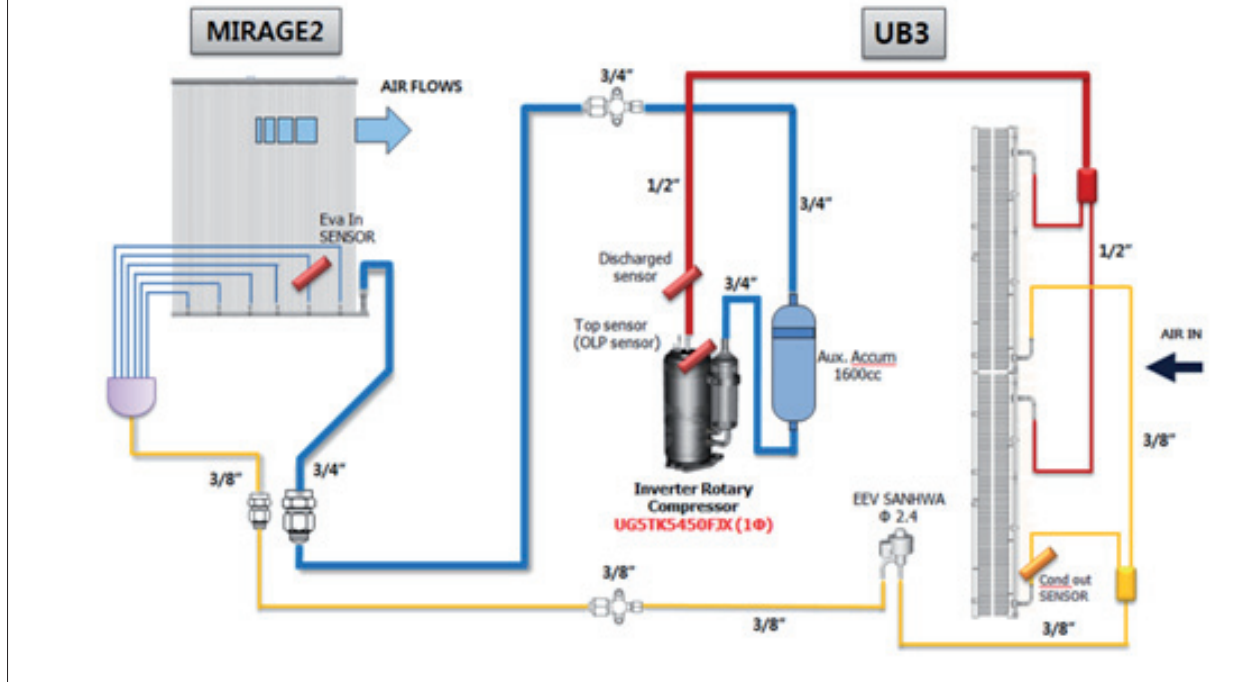

■ AC036KXQPCC

Indoor unit	Heat Exchanger	PFE 12mm, 2X63X785, 6-1PASS, FP1.5, Louver
	Fan Motor	BLDC, Sirocco, [C/H] 430/390/370 [rpm]
Outdoor unit	Heat Exchanger	PFC 16mm, 1R*69S*910, 2EA, FP1.4, Corrugate
	Fan Motor	BLDC, Propeller, RPM MAX : 800 [rpm]

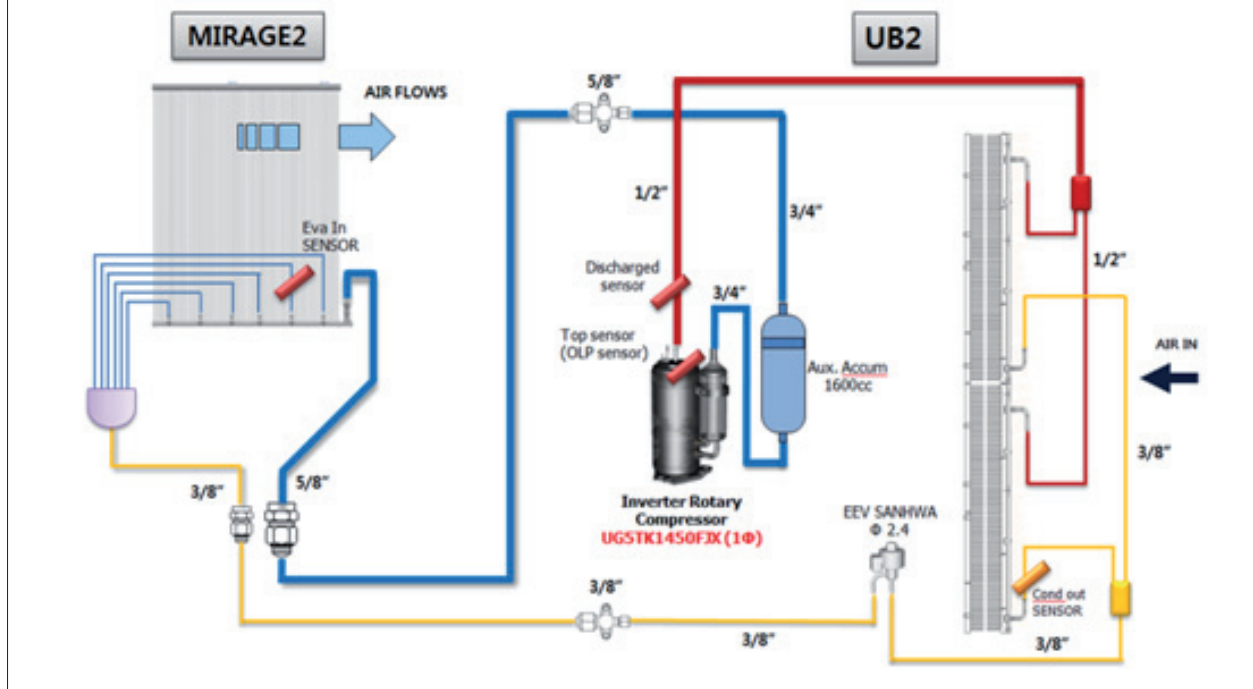

■ AC140KXADGH

Indoor unit	Heat Exchanger	PFE 12mm, 2X63X785, 6-1PASS, FP1.5, Louver
	Fan Motor	BLDC, Sirocco, [C/H] 490/430/390 [rpm]
Outdoor unit	Heat Exchanger	F&T Ø7W, 2R*66S*950, FP1.7, Louver
	Fan Motor	BLDC, Propeller, RPM MAX : 800 [rpm]

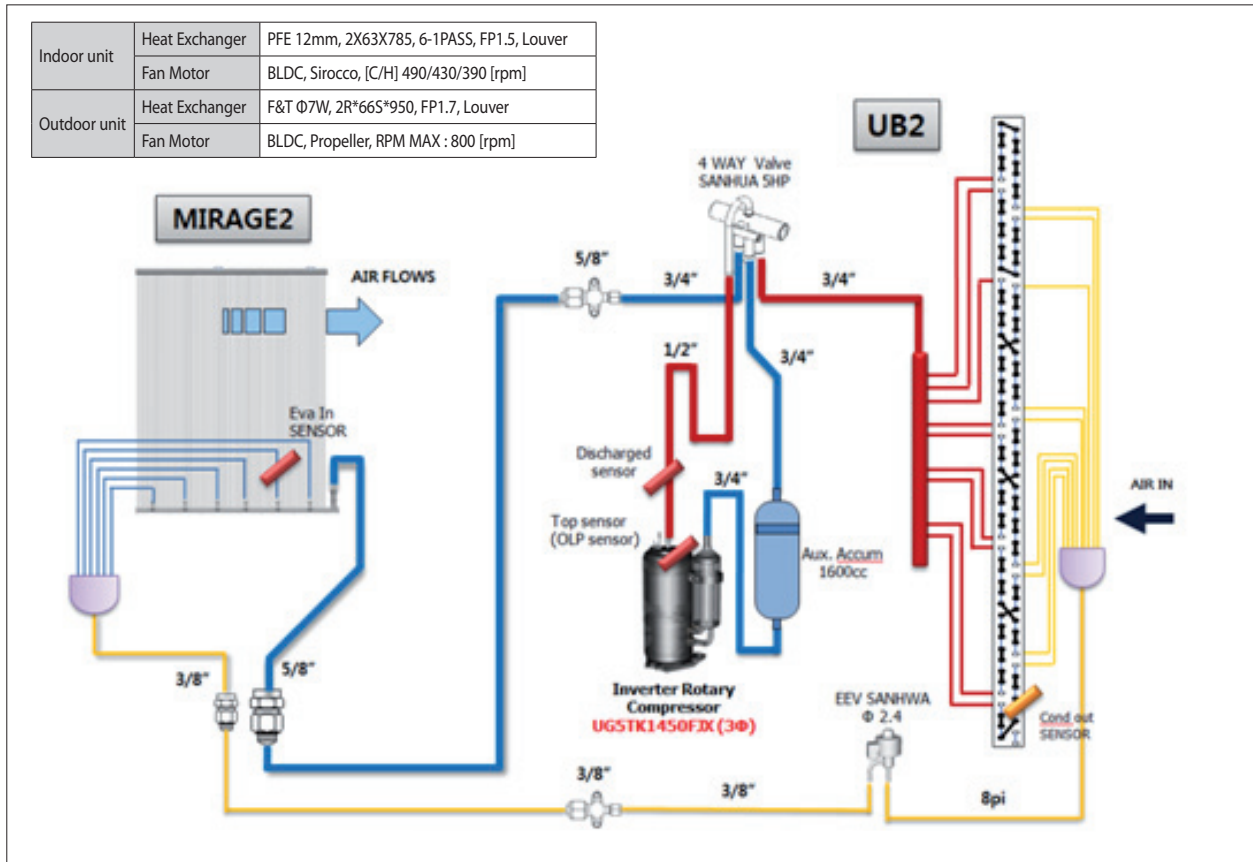

■ AC100KXADEH

Indoor unit	Heat Exchanger	PFE 8mm, 2X63X785, 6-1PASS, FP1.5, Louver
	Fan Motor	BLDC, Sirocco, [C/H] 410/370/350 [rpm]
Outdoor unit	Heat Exchanger	F&T Ø7W, 2R*46S*950, FP1.7, Louver
	Fan Motor	BLDC, Propeller, RPM MAX : 830 [rpm]

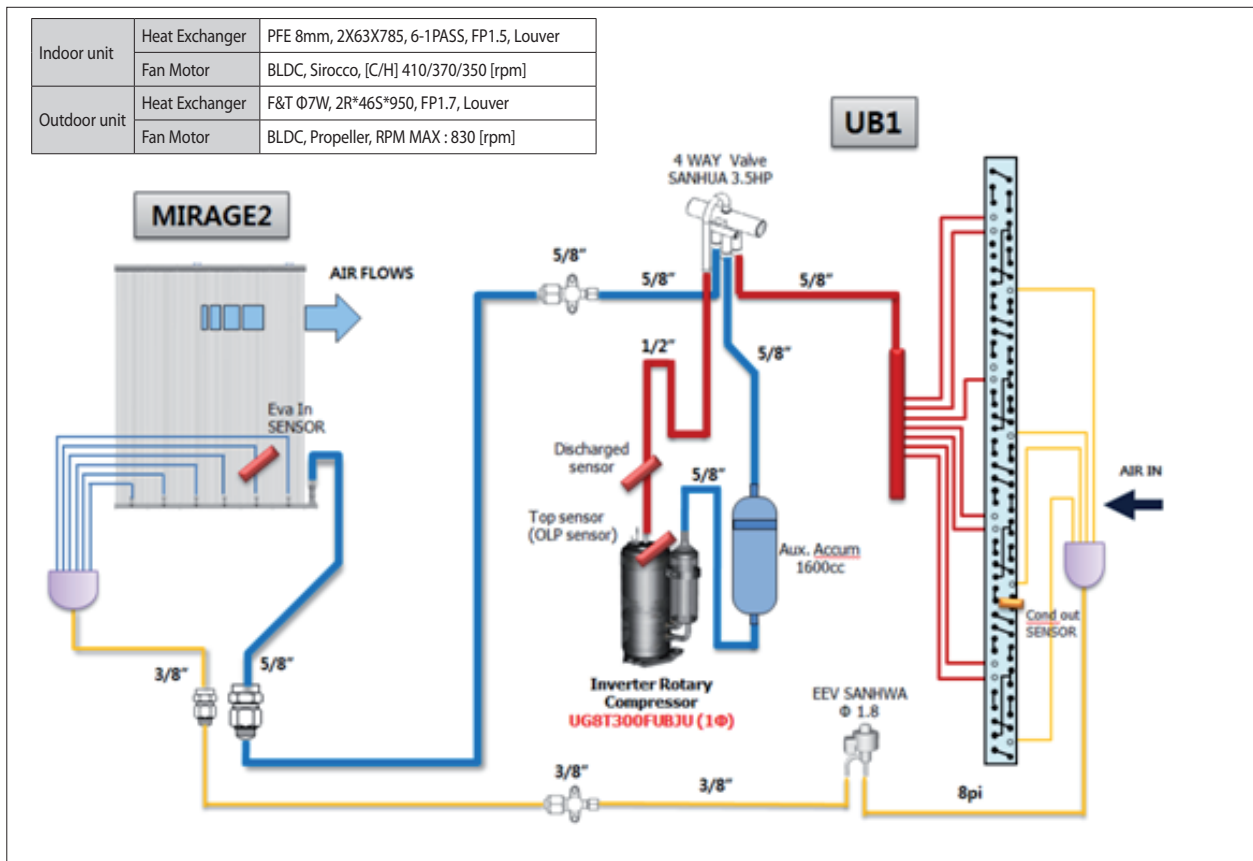

■ AC048KXADGC

Indoor unit	Heat Exchanger	PFE 12mm, 2X63X785, 6-1PASS, FP1.5, Louver
	Fan Motor	BLDC, Sirocco, [C/H] 490/440/390 [rpm]
Outdoor unit	Heat Exchanger	F&T Ø7W, 2R*66S*950, FP1.7, Louver
	Fan Motor	BLDC, Propeller, RPM MAX : 800 [rpm]

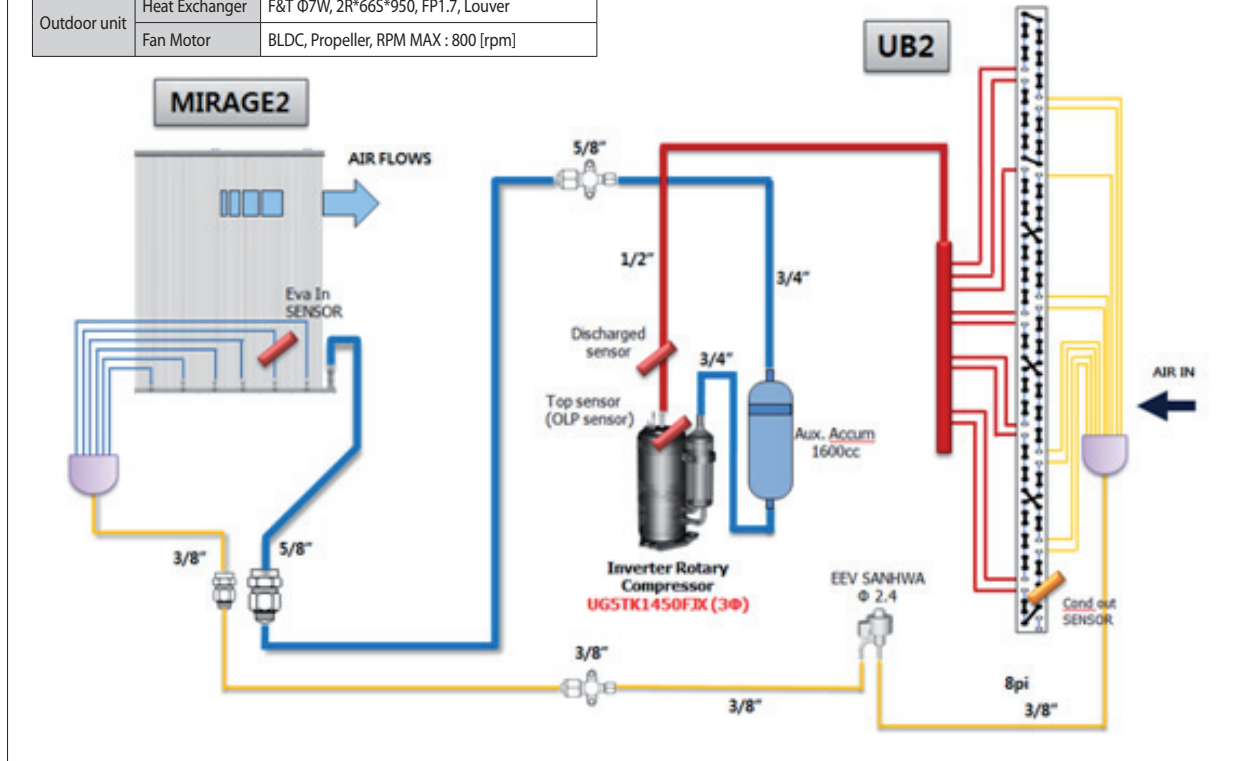

■ AC036KXADGC

Indoor unit	Heat Exchanger	PFE 12mm, 2X63X785, 6-1PASS, FP1.5, Louver
	Fan Motor	BLDC, Sirocco, [C/H] 410/370/350 [rpm]
Outdoor unit	Heat Exchanger	F&T Ø7W, 2R*46S*950, FP1.7, Louver
	Fan Motor	BLDC, Propeller, RPM MAX : 830 [rpm]

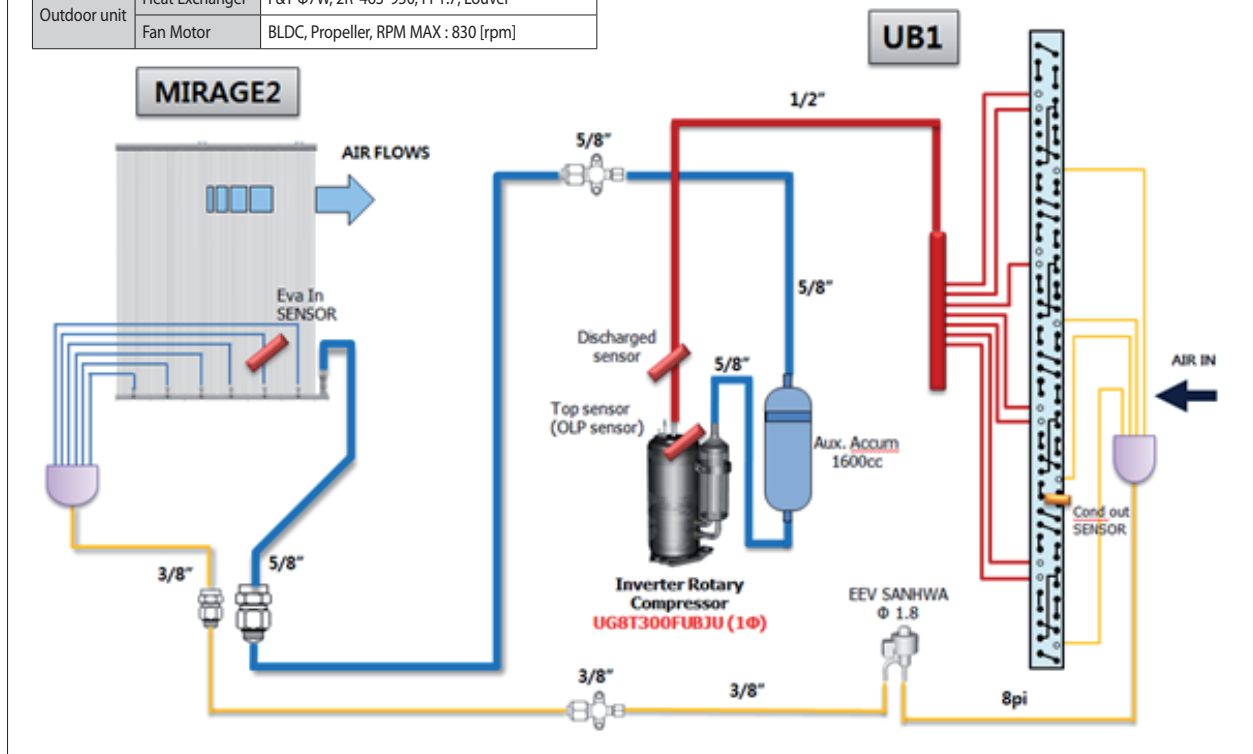



GSPN (GLOBAL SERVICE PARTNER NETWORK)

Area	Web Site
Europe, CIS, Mideast & Africa	gspn1.samsungcsportal.com
Asia	gspn2.samsungcsportal.com
North & Latin America	gspn3.samsungcsportal.com
China	china.samsungportal.com

This Service Manual is a property of Samsung Electronics Co., Ltd.
Any unauthorized use of Manual can be punished under applicable
International and/or domestic law.

© Samsung Electronics Co., Ltd. December. 2017.
Printed in Korea.
Code No. AC-00163E_1